

TEXTE

65/2020

# Reactive nitrogen flows in Germany 2010-2014 (DESTINO Report 2)

Final Report



TEXTE 65/2020

Environmental Research of the  
Federal Ministry for the  
Environment, Nature Conservation  
and Nuclear Safety

Project No. (FKZ) 3716 51 2000  
Report No. FB000254/ENG,2

## **Reactive nitrogen flows in Germany 2010- 2014 (DESTINO Report 2)**

by

Martin Bach, Uwe Häußermann, Laura Klement, Lukas Knoll, Lutz Breuer  
Institute of Landscape Ecology and Resource Management, University of  
Giessen

Tatyana Weber, Stefan Fuchs  
Karlsruhe Institute for Technology, Karlsruhe

Jürg Heldstab, Judith Reutimann, Bettina Schächli  
INFRAS AG, Zurich

Richard Holmes (translation)  
Scientific and technical translations, Berlin

On behalf of the German Environment Agency

## Imprint

### **Publisher:**

Umweltbundesamt  
Wörlitzer Platz 1  
06844 Dessau-Roßlau  
Tel: +49 340-2103-0  
Fax: +49 340-2103-2285  
buergerservice@uba.de  
Internet: [www.umweltbundesamt.de](http://www.umweltbundesamt.de)

 /umweltbundesamt.de

 /umweltbundesamt

### **Study performed by:**

Institute of Landscape Ecology and Resource Management,  
Karlsruhe Institute for Technology,  
INFRAS AG, Zurich

### **Study completed in:**

May 2019

### **Edited by:**

Section II 4.3 Air Pollution and Terrestrial Ecosystems  
Markus Geupel

### **Publication as pdf:**

<http://www.umweltbundesamt.de/publikationen>

ISSN 1862-4804

Dessau-Roßlau, May 2020

## Abstract

Emissions of reactive nitrogen give rise to a wide range of environmental problems. In order to develop reduction measures it is necessary to quantify sources, sinks and flows of  $N_r$ , and as part of the Convention on Long-Range Transboundary Air Pollution (CLTRAP) it was agreed in the Gothenburg Protocol to construct national nitrogen budgets. The “Guidance document on national nitrogen budgets” of the Economic Commission for Europe forms the starting point for this task. The  $N_r$  flows are determined for the following pools: “Atmosphere”, “Energy and Fuels”, “Material and products in industry”, “Humans and settlements”, “Agriculture”, “Forest and semi-natural vegetation”, “Waste”, and “Hydrosphere”, as well as for the “Trans-boundary N-flows” (imports and exports). The N-flows are taken directly from statistical reports, publications, etc., or are calculated as the product of the quantity of transported or converted substance and the mean nitrogen contents. Some 150 N-flows are described, and the uncertainty of the results is graded in four levels from “very low” to “high”. In Germany, approximately 6275 kt  $N_r$  is introduced into the nitrogen cycle every year (mean value from 2010 to 2014), of 43 % is by ammonia synthesis. Domestic extraction of nitrogenous fossil fuels (lignite, coal, crude oil) and imports contribute 2335 kt  $N a^{-1}$ . Natural nitrogen fixation converts 308 kt  $N a^{-1}$  into organically bound nitrogen. Conversely, processes involving the combustion of fossil fuels and regenerative fuels and the refining of crude oil to mineral oil products result in 2711 kt  $N a^{-1}$  being transformed to  $N_2$ . In waters, soils, and wastewater treatment plants, denitrification leads to the release of 1107 kt  $N a^{-1}$  as molecular nitrogen. Via the atmosphere and hydrosphere, Germany exports 745 kt  $N a^{-1}$  to neighbouring countries and the coastal waters. The changes in N-stock in soils have to date only been determined for forest soils, where they are 293 kt  $N a^{-1}$ . On balance, reactive nitrogen totalling 1627 kt  $N$  is released in Germany every year, with negative impacts on the ecosystems and their functions. The national nitrogen budget involves considerable uncertainties, and this should be taken into consideration when interpreting the results.

## Kurzbeschreibung

Der Eintrag von Stickstoff in die Umwelt verursacht vielfältige Probleme. Für die Konzeption von Minderungsmaßnahmen ist es eine wesentliche Voraussetzung, die Quellen, Senken und Flüsse reaktiver Stickstoffverbindungen ( $N_r$ ) zu quantifizieren. Im Rahmen des überarbeiteten Göteborg-Protokolls zur Convention on Long-Range Transboundary Air Pollution (CLTRAP) wurde 2012 vereinbart, die nationalen Stickstoff-Flüsse zu erfassen. Das „Guidance document on national nitrogen budgets“ der Economic Commission for Europe bildet dafür den Ausgangspunkt (ECE 2013). In einer nationalen N-Bilanzierung (NNB) werden für acht Pools die ein- und ausgehenden  $N_r$ -Flüsse berechnet: Atmosphäre, Energiewirtschaft und Verkehr, Industrielle Produktion, Ernährung und Konsum, Landwirtschaft, Wald und semi-natürliche Flächen, Abfallwirtschaft und Abwasserentsorgung, Gewässer sowie die grenzüberschreitenden N-Flüsse (Importe und Exporte). Die N-Flüsse werden aus statistischen Berichten, Veröffentlichungen etc. direkt entnommen oder als Produkt aus der transportierten bzw. umgesetzten Stoffmenge und deren mittlerem N-Gehalt berechnet. Insgesamt werden für Deutschland rund 150 N-Flüsse beschrieben, die Unsicherheit der Ergebnisse wird in vier Stufen von „sehr gering“ bis „hoch“ eingestuft. In Deutschland werden jährlich 6275 kt  $N_r a^{-1}$  in Umlauf gebracht (Mittelwert 2010 bis 2014), davon 43 % über die Ammoniak-Synthese. Die inländische Förderung und der Import von N-haltigen fossilen Energieträgern (Braunkohle, Steinkohle, Rohöl) tragen 2335 kt  $N a^{-1}$  dazu bei. Mit der Stickstoff-Fixierung als einzigem natürlichen Prozess werden 308 kt  $N a^{-1}$  in organisch gebundenen Stickstoff überführt. Als bedeutendste Senke von  $N_r$  werden mit der Verbrennung von fossilen und regenerativen Energieträgern sowie mit der Verarbeitung von Rohöl zu Mineralölprodukten 2711 kt  $N a^{-1}$  wieder in  $N_2$  überführt. In Gewässern, Böden und Kläranlagen werden 1107 kt  $N a^{-1}$  denitrifiziert. Über die

Atmosphäre und den Gewässerabfluss exportiert Deutschland netto 745 kt N a<sup>-1</sup> in seine Nachbarländer und in die Küstenmeere. Die Änderung des N-Bodenvorrats wurde bislang nur für Waldböden ermittelt, für die ein Abbau von 293 kt N a<sup>-1</sup> berechnet wird. Der NNB zufolge werden in Deutschland jährlich 1627 kt N<sub>r</sub> a<sup>-1</sup> freigesetzt. Die NNB ist allerdings durch größere Unsicherheiten gekennzeichnet, was bei der Interpretation der Ergebnisse berücksichtigt werden muss.

## Contents

|   |           |
|---|-----------|
| <b>Contents</b> .....   | <b>4</b>  |
| <b>Lists of figures</b> .....   | <b>8</b>  |
| <b>Lists of tables</b> .....  | <b>9</b>  |
| <b>Abbreviations and acronyms</b> .....   | <b>13</b> |
| <b>Summary</b> .....  | <b>15</b> |
| <b>1 Introduction</b> .....   | <b>18</b> |
| <b>2 Flows of reactive nitrogen in Germany – An overview</b> .....  | <b>20</b> |
| 2.1 Nitrogen pools, sub-pools and nitrogen flows.....   | 20        |
| 2.2 Determining nitrogen flows .....  | 23        |
| 2.3 Range of uncertainty .....  | 24        |
| <b>3 Atmosphere (AT)</b> .....  | <b>25</b> |
| 3.1 Land use in Germany.....  | 26        |
| 3.2 N <sub>2</sub> O and NO <sub>x</sub> emissions into the atmosphere.....   | 29        |
| 3.2.1 N <sub>2</sub> O and NO <sub>x</sub> emissions .....  | 29        |
| 3.2.2 NO <sub>x</sub> -formation by lightning.....  | 30        |
| 3.3 NH <sub>3</sub> emissions into the atmosphere .....   | 30        |
| 3.4 Atmospheric NH <sub>y</sub> and NO <sub>x</sub> depositions.....  | 31        |
| 3.5 Imports and exports of NH <sub>y</sub> and NO <sub>x</sub> .....  | 33        |
| 3.6 Summary of N-flows for the “Atmosphere” (AT) pool.....  | 33        |
| 3.7 Balance and comments for the “Atmosphere” (AT) pool .....   | 35        |
| 3.8 Uncertainty assessment for the N-flows of “Atmosphere” (AT) pool .....  | 36        |
| <b>4 Energy and Fuels (EF)</b> .....  | <b>38</b> |
| 4.1 Sub-pool “Energy Conversion” (EF.EC).....   | 39        |
| 4.1.1 Origin and use of fossil fuels (XX-EF.EC-fuel, EF.EC-XX-fuel).....  | 39        |
| 4.1.2 Formation of thermal NO <sub>x</sub> .....  | 42        |
| 4.1.3 Producing fuel from biomass (MP.FP-EF.EC-fuel).....   | 43        |
| 4.1.4 Ammonia consumption for flue gas denoxing (MP.NC-EF.EC-prod).....   | 43        |
| 4.1.5 Oxidation/reduction of nitrogen by combustion and denoxing (EF.EC-SINK-N2) .....  | 44        |
| 4.2 Sub-pools “Manufacturing Industries and Construction” (EF.IC), “Transport” (EF.TR) and<br>“Other Energy and fuels” (EF.OE)..... | 45        |
| 4.3 Summary of N-flows for the “Energy and Fuels” (EF) pool.....  | 46        |
| 4.4 Balance and comments for the “Energy and Fuels” (EF) pool .....   | 47        |
| 4.5 Uncertainty assessment for N-flows of “Energy and Fuels” (EF) pool.....   | 49        |
| <b>5 Materials and Products in Industry (MP)</b> .....  | <b>50</b> |



|          |  |           |
|----------|--|-----------|
| 5.1      | Sub-pool “Food and Feed Processing” (MP.FP) .....  | 52        |
| 5.1.1    | Foodstuffs for human consumption (MP.FP-HS.HB-food) .....  | 52        |
| 5.1.2    | Feed for pets (MP.FP-HS.HB-feed) .....   | 53        |
| 5.1.3    | Crops as industrial resources (MP.FP-MP.OP-crop) .....   | 53        |
| 5.1.4    | Rendering of animal by-products .....  | 54        |
| 5.1.5    | Imports and exports for the food industry (RW-MP.FP-prod, MP.FP-RW-prod) .....                       | 54        |
| 5.2      | Sub-pool “Nitrogen Chemistry” (MP.NC) .....  | 55        |
| 5.2.1    | Ammonia synthesis (SOURCE-MP.NC-NH3) .....   | 55        |
| 5.2.2    | Production, import and export of chemicals (MP.NC-MP.OP-prod, RW-MP.NC-prod,<br>MP.NC-RW-prod) ..... | 55        |
| 5.2.3    | Nitrogen-mineral fertiliser (MP.NC-AG.SM-minFert; MP.NC-HS.MV-minFert) .....                         | 59        |
| 5.3      | Sub-pool “Other Producing Industry” (MP.OP) .....  | 59        |
| 5.4      | Summary of N-flows for Materials and Products in “Industry” (MP) pool .....                          | 60        |
| 5.5      | Balance and comments for the “Materials and Products in Industry” (MP) pool .....                    | 62        |
| 5.6      | Uncertainty assessment for the N-flows of “Materials and Products in Industry” (MP) pool .....       | 63        |
| <b>6</b> | <b>Humans and Settlements (HS) .....</b>   | <b>67</b> |
| 6.1      | Sub-pool “Human Body” (HS.HB) .....  | 68        |
| 6.2      | Sub-pool “Material World” (HS.MW) .....  | 68        |
| 6.3      | Summary of N-flows for “Humans and Settlements” (HS) pool .....                                      | 69        |
| 6.4      | Balance and comments for the “Humans and Settlements” (HS) pool .....                                | 70        |
| 6.5      | Uncertainty assessment for the N-flows of “Humans and Settlements” (HS) pool .....                   | 70        |
| <b>7</b> | <b>Agriculture (AG) .....</b>  | <b>72</b> |
| 7.1      | Sub-pool “Animal Husbandry” (AG.AH) .....  | 75        |
| 7.1.1    | Agricultural animal husbandry (XX.XX-AG.AH, AG.AH-XX.XX) .....                                       | 75        |
| 7.1.2    | Aquaculture and inland fisheries (AG.AH-fish) .....  | 75        |
| 7.2      | Sub-pool “Soil Management” (AG.SM) .....   | 75        |
| 7.2.1    | Soil Management (XX.XX-AG.SM, AG.SM-XX.XX) .....   | 76        |
| 7.2.2    | NO <sub>3</sub> <sup>-</sup> in irrigation water (HY.GW-AG.SM-irrig) .....                           | 77        |
| 7.2.3    | Denitrification in soils in utilised agricultural areas (AG.SM-AT-N2) .....                          | 77        |
| 7.2.4    | Discharges into the Hydrosphere (AG.SM-HY.GW-leach, AG.SM-HY.GW-runoff) .....                        | 77        |
| 7.3      | Sub-pool “Biogas production” (AG.BP) .....   | 77        |
| 7.4      | Summary of N-flows for the “Agriculture” (AG) pool .....   | 78        |
| 7.5      | Balance and comments for the “Agriculture” (AG) pool .....   | 80        |
| 7.5.1    | Balance of N-flows in agriculture .....  | 80        |
| 7.5.2    | N-stock in soil and changes in stock .....   | 80        |



|          |  |           |
|----------|--|-----------|
| 7.5.3    | Comparison with the N-balance of BMEL .....  | 81        |
| 7.5.4    | Comments on National Nitrogen Budget Annex 3.....  | 82        |
| 7.6      | Uncertainty assessment for the N-flows of “Agriculture” (AG) pool .....  | 82        |
| <b>8</b> | <b>Forest and semi-natural vegetation (FS) .....</b>   | <b>86</b> |
| 8.1      | Sub-pool “Forest” (FS.FO) .....  | 87        |
| 8.1.1    | Forest area .....  | 87        |
| 8.1.2    | Biological nitrogen fixation in forest soils (AT-FS.FO-Nfix) .....   | 88        |
| 8.1.3    | Denitrification in forest areas (AT.FS.FO.N2).....   | 88        |
| 8.1.4    | Nitrate leaching from forest soils (FS.FO-HY.SW-leach) .....   | 88        |
| 8.1.5    | Wood removal and uses of wood (FS.FO-MP.OP-wood, FS.FO-EF.OE-wood, FS.FO-RW-wood,<br>RW-FS.FO-wood).....   | 89        |
| 8.1.6    | Balance and changes in stocks for the “Forest” sub-pool (wood stands and forest soils) .....   | 90        |
| 8.2      | Sub-pool “Other land covered with semi-natural vegetation” (FS.OL).....  | 92        |
| 8.2.1    | Biological nitrogen fixing in Other land (AT-FS.OL-Nfix) .....   | 93        |
| 8.2.2    | Denitrification in Other land (AT-FS.OL-N2).....   | 93        |
| 8.2.3    | Nitrate leaching from Other land (FS.OL-HY.SW-leach).....  | 93        |
| 8.3      | Sub-pool “Wetlands” (FS.WL) .....  | 93        |
| 8.3.1    | Biological nitrogen fixation in Wetland (AT-FS.WL-Nfix) .....  | 93        |
| 8.3.2    | N-inflow with runoff (AG.SM-FS.WL-runoff).....   | 94        |
| 8.3.3    | Denitrification in Wetland (AT-FS.WL-N2) .....   | 94        |
| 8.3.4    | Nitrate leaching from Wetland (FS.WL-HY.SW-leach) .....  | 94        |
| 8.4      | Summary of N-flows for the “Forest and Semi-natural vegetation” (FS) pool .....  | 94        |
| 8.5      | Uncertainty assessment for N-flows of “Forest and Semi-natural vegetation” (FS) pool .....   | 95        |
| <b>9</b> | <b>Waste (WS) .....</b>  | <b>98</b> |
| 9.1      | Sub-Pool “Solid Waste” (WS.SW).....  | 99        |
| 9.1.1    | Amounts of waste (XX.XX-WS.SW-waste).....  | 100       |
| 9.1.2    | Disposal and recycling of waste (WS.SW-XX.XX-waste).....   | 102       |
| 9.1.3    | Import and export of waste (RW-WS.SW-waste, WS.SW-RW-waste).....   | 104       |
| 9.2      | Sub-pool “Wastewater” (WS.WW) .....  | 105       |
| 9.2.1    | Sewage from households, industry (direct and indirect dischargers) and from sealed areas<br>(EF.EC-WS.WW-sewage, MP.XX-WS.WW-sewage, HS.XX-sewage) ..... | 105       |
| 9.2.2    | Sludge and sludge disposal (WS.WW-HS.MW-sludge, WS.WW-AG.SM-sludge,<br>WS.WW-WS.SW-sludge) .....   | 106       |
| 9.2.3    | N-discharge into surface waters from settlement wastewater management .....  | 107       |
| 9.2.4    | Denitrification in municipal and non-public wastewater treatment plants (WS.WW-AT-N2) .....  | 108       |
| 9.3      | Summary of N-flows for the “Waste” (WS) pool .....   | 108       |

|           |  |            |
|-----------|--|------------|
| 9.4       | Balance and comments for the “Waste” (WS) pool .....   | 110        |
| 9.5       | Uncertainty assessment for the N-flows for “Waste” (WS) pool.....  | 112        |
| <b>10</b> | <b>Hydrosphere (HY) .....</b>  | <b>115</b> |
| 10.1      | Sub-pool “Groundwater” (HY.GW) .....   | 116        |
| 10.1.1    | Nitrate leaching (AG.XX-HY.GW-leach, FS.XX-HY.GW-leach).....   | 116        |
| 10.1.2    | N-flows from groundwater (HY.GW-AT-N2, HY.GW-AG.SM-abstr, HY.GW-AG.SM-irrig,<br>HY.GW-HY.SW-discharge) ..... | 117        |
| 10.2      | Sub-pools “Surface Waters” (HY.SW) and “Coastal Waters” (HY.CW) .....  | 118        |
| 10.2.1    | Run-off from agricultural areas into surface waters (AG.SM-HY.SW-runoff) .....                               | 118        |
| 10.2.2    | Denitrification in surface waters and coastal waters (HY.SW-AT-N2, HY.CW-AT-N2) .....                        | 119        |
| 10.2.3    | Trans-boundary inflows and outflows (RW-HY.SW-discharge, HY.SW-RW-discharge) .....                           | 119        |
| 10.2.4    | Sea fishing (HY.CW-MP.FP-fish) .....   | 120        |
| 10.3      | Summary of N-flows for the “Hydrosphere” (HY) pool.....  | 120        |
| 10.4      | Balance and comments for the “Hydrosphere” (HY) pool.....  | 121        |
| 10.5      | Uncertainty assessment for the N-flows of “Hydrosphere” (HY) pool .....                                      | 122        |
| <b>11</b> | <b>Trans-boundary N-flows (RW) .....</b>   | <b>125</b> |
| <b>12</b> | <b>Presenting N-flows with STAN.....</b>   | <b>127</b> |
| <b>13</b> | <b>Overview and balance of N-flows for Germany .....</b>   | <b>136</b> |
| <b>14</b> | <b>Conclusions .....</b>   | <b>141</b> |
| <b>15</b> | <b>Acknowledgements .....</b>  | <b>143</b> |
| <b>16</b> | <b>Literature .....</b>  | <b>144</b> |

## Lists of figures

|              |   |     |
|--------------|---|-----|
| Figure 12-1: | Nitrogen-pools, sub-pools and N-flows (in kt N a <sup>-1</sup> , annual mean for 2010 – 2014) of the German national nitrogen budget. ....  | 127 |
| Figure 12-2: | “Atmosphere” pool with nitrogen inflows and outflows (in kt N a <sup>-1</sup> , annual mean for 2010 – 2014). ....  | 128 |
| Figure 12-3: | “Energy and Fuels” pool and its sub-pools with nitrogen inflows and outflows (in kt N a <sup>-1</sup> , annual mean for 2010 – 2014). ....  | 129 |
| Figure 12-4: | “Material and Products in Industry” pool and its sub-pools with nitrogen inflows and outflows (in kt N a <sup>-1</sup> , annual mean for 2010 – 2014). ....   | 130 |
| Figure 12-5: | “Humans and Settlements” pool and its sub-pools with nitrogen inflows and outflows (in kt N a <sup>-1</sup> , annual mean for 2010 – 2014). ....  | 131 |
| Figure 12-6: | “Agriculture” pool and its sub-pools with nitrogen inflows and outflows (in kt N a <sup>-1</sup> , annual mean for 2010 – 2014). ....   | 132 |
| Figure 12-7: | “Forest and Semi-natural Vegetation” pool and its sub-pools with inflows and outflows (in kt N a <sup>-1</sup> , annual mean for 2010 – 2014). ....   | 133 |
| Figure 12-8: | “Waste” pool and its sub-pools with inflows and outflows (in kt N a <sup>-1</sup> , annual mean for 2010 – 2014). ....  | 134 |
| Figure 12-9: | “Hydrosphere” pool and its sub-pools with inflows and outflows (in kt N a <sup>-1</sup> , annual mean for 2010 – 2014). ....  | 135 |
| Figure 13-1: | Emissions of reactive nitrogen from anthropogenous sources into the air (NO <sub>x</sub> , NH <sub>3</sub> , N <sub>2</sub> O) and surface waters (NO <sub>3</sub> <sup>-</sup> ) according to nitrogen-species and emitter groups, annual mean for 2010 - 2014. .... | 140 |

## Lists of tables

|             |  |    |
|-------------|--|----|
| Table 2-1:  | Pools and sub-pools of the National Nitrogen Balance for Germany (after ECE 2013, with adaptations).....   | 21 |
| Table 2-2:  | Flow code suffixes for matrices or transport processes.....  | 22 |
| Table 2-3:  | Uncertainty ranges of N-flows (adapted from NNB Annex 0, Table 5). ....  | 24 |
| Table 3-1:  | Inflows (Pool(in)) and outflows (Pool(ex)) of N <sub>r</sub> in the “Atmosphere” pool.....   | 25 |
| Table 3-2:  | CORINE Land Cover classes, grouped under IPCC-Land use categories (NIR) corresponding receptor types of deposition modeling project PINETI-3.....  | 28 |
| Table 3-3:  | A comparison of area data and types of use .....   | 29 |
| Table 3-4:  | N <sub>2</sub> O and NO <sub>x</sub> emissions in Germany according to sectors, annual mean for 2010 - 2014. ....  | 30 |
| Table 3-5:  | NH <sub>3</sub> emissions in Germany, annual mean for 2010 - 2014.....   | 31 |
| Table 3-6:  | Specific deposition rates of reactive nitrogen per hectare calculated on the basis of the real land use distribution (receptor types in PINETI-3 deposition modeling), annual mean for 2010 – 2014. ....                     | 32 |
| Table 3-7:  | N-flows with atmospheric N-deposition, annual mean for 2010 – 2014. ....   | 32 |
| Table 3-8:  | Import and export of reduced (NH <sub>y</sub> ) and oxidised (NO <sub>x</sub> ) atmospheric N-compounds according to EMEP Source-Receptor Tables, annual mean for 2010 – 2014. ....  | 33 |
| Table 3-9:  | Incoming and outgoing N-flows in the “Atmosphere” pool, annual mean for 2010 – 2014. ....  | 33 |
| Table 3-10: | Balance of reactive N-flows in the “Atmosphere” pool for Germany (without denitrification), annual mean for 2010 – 2014.....   | 36 |
| Table 3-11: | Uncertainties in the calculation of N-flows for the “Atmosphere” pool.....   | 37 |
| Table 4-1:  | Incoming and outgoing N-flows of sub-pools of the “Energy and Fuels” pool. ....  | 38 |
| Table 4-2:  | Energy Balance for Germany (except for fossil fuels containing nitrogen) – summarised results with allocation to N-flows, annual mean for 2010 - 2014. ....  | 40 |
| Table 4-3:  | N-flows with imports of crude oil and mineral-oil products as well as from refinery products, annual mean for 2010 – 2014.....   | 41 |
| Table 4-4:  | Proportion of thermal NO <sub>x</sub> emissions in total NO <sub>x</sub> formed by combustion. ....  | 42 |
| Table 4-5:  | Areas, yields and N-flows for energy crops used to produce fuels, annual mean 2012 - 2014. ....  | 43 |
| Table 4-6:  | Estimate of the N <sub>r</sub> quantities oxidised or reduced to N <sub>2</sub> during the combustion of fossil fuels and wood (in large combustion plants) and the denoxing of flue gases, annual mean for 2010 – 2014..... | 45 |
| Table 4-7:  | Incoming and outgoing N-flows of the sub-pools of “Energy and Fuels” <sup>a</sup> , annual mean for 2010 – 2014.....   | 46 |
| Table 4-8:  | Balance of nitrogen inflows and outflows (without agricultural products) in “Energy and Fuels” pool, annual mean for 2010 - 2014.....  | 48 |

|             |   |    |
|-------------|---|----|
| Table 4-9:  | Uncertainties in the calculation of N-flows for “Energy and Fuels” pool.....  | 49 |
| Table 5-1:  | Incoming and outgoing N-flows of the sub-pools in the “Material and Products in Industry” pool.....   | 50 |
| Table 5-2:  | Nitrogen flow with the consumption of foodstuffs – shown in produce groups, annual mean for 2010 – 2014.....  | 52 |
| Table 5-3:  | Nitrogen flow with feed for dogs and cats, annual mean for 2012 - 2014. ....  | 53 |
| Table 5-4:  | Nitrogen flow with crops as industrial resources (without energy crops), annual mean 2012 – 2014. ....  | 53 |
| Table 5-5:  | Rendering of animal by-products – Proteins <sup>a</sup> (mean 2011 - 2014 <sup>b</sup> ) and N-flows according to use and category.....                         | 54 |
| Table 5-6:  | Imports and exports of the food industry and net imports of animal feed, annual mean 2012 – 2014. ....  | 55 |
| Table 5-7:  | Production <sup>a</sup> , import and export of chemicals in sub-pool “Nitrogen Chemistry”, annual mean for 2010 – 2014 .....                                    | 57 |
| Table 5-8:  | Production, import and export of nitrogenous commodities, annual mean for 2010 – 2014. ....   | 59 |
| Table 5-9:  | Incoming and outgoing N-contents of the N-flows of the sub-pools in the “Materials and Products in Industry” pool, annual mean for 2010 – 2014.....             | 60 |
| Table 5-10: | Total inflows and outflows for each sub-pool and for the “Materials and Products in Industry” pool (without internal N-flows), annual mean for 2010 - 2014..... | 62 |
| Table 5-11: | Uncertainties in the calculation of main N-flows for “Materials and products in Industry” pool.....   | 64 |
| Table 6-1:  | Incoming and outgoing N-flows of the sub-pools in the “Humans and Settlements” pool.....  | 67 |
| Table 6-2:  | Incoming and outgoing N-flows for sub-pools in the “Humans and Settlements” pool, annual mean for 2010 – 2014. ....   | 69 |
| Table 6-3:  | Balance for nitrogen inflows and outflows (excluding agricultural products) for the “Humans and Settlements” pool, annual mean for 2010 - 2014.....             | 70 |
| Table 6-4:  | Uncertainties in the calculation of key N-flows for “Humans and Settlements” pool.....  | 71 |
| Table 7-1:  | Incoming and outgoing N-flows of the sub-pools in the “Agriculture” pool.....   | 73 |
| Table 7-2:  | Incoming and outgoing N-flows for the sub-pool “Animal Husbandry” (not including inland fisheries and aquaculture), annual mean for 2010 - 2014.....            | 75 |
| Table 7-3:  | N-flows of the nitrogen balance for sub-pool “Soil Management”, annual mean for 2010 - 2014. ....   | 76 |
| Table 7-4:  | N-flows for the sub-pool “Biogas Production”, annual mean for 2010 - 2014.....  | 78 |
| Table 7-5:  | Incoming and outgoing N-flows of the “Agriculture” sub-pools, mean for 2010 – 2014. ....  | 78 |
| Table 7-6:  | Nitrogen inflows and outflows for the “Agriculture” pool, annual mean for 2010 – 2014. ....   | 80 |

|             |   |     |
|-------------|---|-----|
| Table 7-7:  | Uncertainties in the calculation of important N-flows for the “Agriculture” pool.....   | 83  |
| Table 8-1:  | Incoming and outgoing N-flows of the sub-pools in the “Forest and Semi-natural vegetation” pool.....  | 86  |
| Table 8-2:  | Forest areas (in 1000 ha) according to specifications, 3rd National Forest Inventory 2012.....  | 87  |
| Table 8-3:  | Literature results for nitrate leaching under forest areas.....   | 88  |
| Table 8-4:  | Annual N-flows with the removal and use of wood as well as imports and exports, annual mean for 2010 - 2014. ....   | 90  |
| Table 8-5:  | Mean, standard error and median of the annual change in nitrogen stores in surface humus and in soil (for a range of depths) in German forests, calculated on the basis of the National Forest Soil Surveys BZE II (2006 - 2008) and BZE I (1987 - 1993)..... | 91  |
| Table 8-6:  | Timber stocks (2012) and changes between 2002 and 2012 in forests according to the National Forest Inventory 2012. ....   | 91  |
| Table 8-7:  | Nitrogen inflows and outflows and changes in stock in the “Forest” sub-pool, annual mean for 2010 - 2014. ....  | 92  |
| Table 8-8:  | Incoming and outgoing N-flows of the sub-pools of the “Forest and semi-natural vegetation” pool, annual mean for 2010 – 2014.....   | 94  |
| Table 8-9:  | Uncertainties in the calculation of the main N-flows for the “Forest and Semi-natural vegetation” pool.....   | 96  |
| Table 9-1:  | Incoming and outgoing N-flows of the sub-pools in the “Waste” pool. ....  | 98  |
| Table 9-2:  | Quantities of waste (only types of waste that probably contain nitrogen) and allocation of sub-pools of origin, annual mean for 2010/2012/2014. ....  | 101 |
| Table 9-3:  | Fate of waste, allocation to three N-flows (only probably nitrogenous wastes <sup>a</sup> shown, “hazardous” and “non-hazardous” wastes are combined), annual mean for 2010 - 2014. ....  | 103 |
| Table 9-4:  | N-flows with the import and export of notifiable waste materials, annual mean for 2010 – 2014.....  | 104 |
| Table 9-5:  | N-contents in wastewater (sewage) from households, from sealed areas and from industrial dischargers.....   | 106 |
| Table 9-6:  | Sludge disposal from public and non-public wastewater treatment, for 2013 and allocation to N-flows.....  | 107 |
| Table 9-7:  | Nitrogen discharge into surface waters from municipal wastewater treatment plants and sewerage systems (settlement wastewater management) on the basis of MoRE modelling, annual mean for 2010 – 2014. ....   | 108 |
| Table 9-8:  | Incoming and outgoing N-flows of sub-pools in the “Waste” pool, annual mean for 2010 – 2014.....  | 109 |
| Table 9-9:  | N <sub>r</sub> inflows and outflows for the “Solid Waste” sub-pool, annual mean for 2010 – 2014. ....   | 111 |
| Table 9-10: | N <sub>r</sub> inflows and outflows for the sub-pool “Wastewater”, annual mean for 2010 – 2014. ....  | 112 |

|             |   |     |
|-------------|---|-----|
| Table 9-11: | Uncertainties in the calculation of N-flows for “Waste” pool.....   | 113 |
| Table 10-1: | Incoming and outgoing N-flows for the “Hydrosphere” sub-pools.....  | 115 |
| Table 10-2: | Nitrate leaching in the sub-pool “Groundwater”.....   | 117 |
| Table 10-3: | Nitrogen discharge from the sub-pool “Groundwater”.....   | 118 |
| Table 10-4: | Nitrogen flows into surface waters from the “Agriculture” pool by lateral transport according to MoRE-modelling, annual mean for 2010 – 2014.....                         | 118 |
| Table 10-5: | N-load in the trans-boundary inflow and outflow of surface waters, mean 2010 – 2014.....  | 119 |
| Table 10-6: | Incoming and outgoing N-flows for the sub-pools of the “Hydrosphere” pool; annual mean for 2010 – 2014.....   | 120 |
| Table 10-7: | Nitrogen inflows and outflows for the “Hydrosphere” pool, annual mean for 2010 – 2014.....  | 122 |
| Table 10-8: | Uncertainties in the calculation of the largest N-flows for the “Hydrosphere” pool.....   | 123 |
| Table 11-1: | Imports and exports (incoming and outgoing N-flows) in the “Trans-boundary N-flows” pool, annual mean for 2010 – 2014.....  | 125 |
| Table 11-2: | Imports and exports of reactive nitrogen for pools or sub-pools, annual mean for 2010 – 2014.....   | 126 |
| Table 13-1: | Sources and sinks of reactive nitrogen in Germany, annual mean for 2010 – 2014.....   | 136 |
| Table 13-2: | Comparison of the nitrogen inflows and outflows of the pools or sub-pools, annual mean for 2010 – 2014.....   | 138 |
| Table 13-3: | Emitting groups, and quantities and percentages of key N <sub>r</sub> emissions from anthropogenous sources into air and surface waters, annual mean for 2010 – 2014..... | 139 |



## Abbreviations and acronyms

|                                   |  |
|-----------------------------------|--|
| <b>BAFU</b>                       | Federal Office for the Environment (Switzerland)                                       |
| <b>BfG</b>                        | German Federal Institute of Hydrology  |
| <b>BMEL</b>                       | Federal Ministry of Food and Agriculture   |
| <b>BMELV</b>                      | Federal Ministry for Food, Agriculture and Consumer Protection (until 2013)            |
| <b>BMUB</b>                       | Federal Ministry for the Environment, Nature Conservation, Housing, and Nuclear Safety |
| <b>BZE I</b>                      | First National Forest Soil Survey 1987 - 1993  |
| <b>BZE II</b>                     | Second National Forest Soil Survey 2006 - 2008   |
| <b>CLC2006</b>                    | CORINE Land Cover 2006 (Germany)   |
| <b>CLC2012</b>                    | CORINE Land Cover 2012 (Germany)   |
| <b>(C)LRTAP</b>                   | (Convention on) Long-Range Transboundary Air Pollution                                 |
| <b>CO<sub>2</sub>(eq)</b>         | CO <sub>2</sub> -equivalent  |
| <b>CRF</b>                        | Common Reporting Format (GHG Inventory Submissions data tables)                        |
| <b>DESTATIS</b>                   | German Federal Statistical Office  |
| <b>ECE</b>                        | Economic Commission for Europe (UN)  |
| <b>EMEP</b>                       | European Monitoring and Evaluation Programme   |
| <b>EPNB</b>                       | Expert Panel on Nitrogen Budgets   |
| <b>FAO</b>                        | Food and Agriculture Organization of the United Nations                                |
| <b>GENESIS</b>                    | Database of the Federal Statistical Office   |
| <b>IPCC</b>                       | Intergovernmental Panel on Climate Change  |
| <b>kt</b>                         | Kilotonne (1kt = 10 <sup>6</sup> kg)   |
| <b>LULFC</b>                      | Land Use, Land-Use Change and Forestry   |
| <b>MCU</b>                        | Minimum cartographic unit  |
| <b>N</b>                          | Nitrogen   |
| <b>N<sub>2</sub>O</b>             | Dinitrogen oxide   |
| <b>NH<sub>3</sub></b>             | Ammonia  |
| <b>NH<sub>4</sub><sup>+</sup></b> | Ammonium (ion)   |
| <b>NH<sub>y</sub></b>             | Reduced nitrogen compounds or ions (NH <sub>3</sub> , NH <sub>4</sub> <sup>+</sup> )   |
| <b>NIR</b>                        | National Inventory Report  |
| <b>NNB</b>                        | National Nitrogen Budget   |
| <b>NO<sub>2</sub></b>             | Nitrogen dioxide (gas); nitrite (ion)  |
| <b>NO<sub>3</sub><sup>-</sup></b> | Nitrate (ions)   |
| <b>NO<sub>x</sub></b>             | Oxidised gaseous nitrogen compounds (NO, N <sub>2</sub> O)                             |
| <b>N<sub>r</sub></b>              | Reactive nitrogen  |

|               |   |
|---------------|---|
| <b>N(org)</b> | Nitrogen contained in organic compounds (proteins, nitrogenous chemicals) |
| <b>N(tot)</b> | Total amount of nitrogen (for all N-species)                              |
| <b>PINETI</b> | Pollutant Input and Ecosystem Impact (modelling atmospheric depositions)  |
| <b>PRTR</b>   | Pollutant Release and Transfer Register                                   |
| <b>TJ</b>     | Tera-Joule  |
| <b>UAA</b>    | Utilized agricultural area  |
| <b>UBA</b>    | Germany Environment Agency  |
| <b>UNECE</b>  | United Nations Economic Commission for Europe                             |
| <b>UNFCCC</b> | United Nations Framework Convention on Climate Change                     |

## Summary

Nitrogen is essential for all forms of life, and it forms an integral part of proteins and many other compounds. Over the past century, humans have intervened in the nitrogen cycle more than in any other geochemical cycle. The excessive release of reactive nitrogen into the environment causes numerous problems, including the loss of aquatic and terrestrial biodiversity, the formation of greenhouse gases, air pollution, and increased nitrate levels in groundwater and marine ecosystems. The planetary boundaries for nitrogen have clearly been crossed, and the reduction of nitrogen emissions must therefore be a key goal of environmental policies. Nitrogen occurs in a variety of forms (N-species) such as ammonia/ammonium ( $\text{NH}_3/\text{NH}_4^+$ ), nitrogen oxides ( $\text{NO}$ ,  $\text{NO}_2$ ), nitrous oxide ( $\text{N}_2\text{O}$ ), nitrate ( $\text{NO}_3^-$ ), nitrite ( $\text{NO}_2^-$ ) as well as nitrogen in organic compounds ( $\text{N}_{\text{org}}$ ) in soils, vegetation, animals, food and feed, manufacturing products, etc. For the development of a reduction strategy it is necessary first to identify the relevant sources, sinks, and flows of reactive nitrogen ( $\text{N}_r$ ).

In the revised Gothenburg Protocol to the Convention on Long-Range Transboundary Air Pollution (CLTRAP) it was agreed to develop national nitrogen budgets. The “Guidance document on national nitrogen budgets” (ECE 2013) forms the starting point for our investigation. Reactive nitrogen flows in Germany are determined for eight pools (economic sectors or environmental media). For each pool and the relevant sub-pools, the nitrogen inflows and outflows to and from the other pools and sub-pools are determined, as well as trans-boundary N-flows (imports and exports). In most cases, the values for the N-flows are either taken directly from statistical reports and other publications, or they are calculated as the product of the transported or converted quantity of matrix multiplied by the mean N-contents of the matrix. Transport media are air, water, biomass (e.g. agricultural produce, foodstuffs) and industrial products (e.g. mineral fertiliser, plastics, or consumer goods). A total of some 150 nitrogen flows are described, and the results are given as the annual mean over the period 2010 to 2014. The uncertainty of the N-flows is rated in four levels from “very low” to “high”.

The “Atmosphere” pool includes the emissions and depositions of  $\text{NO}_x$ ,  $\text{N}_2\text{O}$ , and  $\text{NH}_y$ . Data for  $\text{NO}_x$  and  $\text{N}_2\text{O}$  emissions are taken from the National Inventory Report (UBA 2016a), for  $\text{NH}_3$  emissions from the CLRTAP Report (UBA 2017b), and figures for  $\text{NH}_y$  and  $\text{NO}_x$  depositions are based on a national deposition modeling approach (PINETI-3, Schaap et al. 2018). In total, 1053 kt  $\text{N a}^{-1}$  were emitted in Germany and 532 kt  $\text{N a}^{-1}$  deposited from the atmosphere. Net trans-boundary N-flows of 311 kt  $\text{N a}^{-1}$  left federal territories via the atmosphere.

The “Energy and Fuels” pool includes the N-flows arising in the course of energy conversion and the use of fuels in combustion processes. Data is drawn from the Energy Balance for Germany (AGEB 2017). The inflow of 2662 kt  $\text{N a}^{-1}$  is almost exclusively contained in the imported and domestically extracted fossil fuels (lignite, coal, crude oil). We assume that the large amounts of nitrogen in the fuels are mostly converted to molecular nitrogen during combustion processes or the refining of crude oil, with the exception of  $\text{NO}_x$  that is formed. However, this assumption could not be tested further, so that the balance for this pool remains very uncertain.

The “Materials and Products in Industry” pool includes the N-flows associated with the production and (non-energetic) use of products containing nitrogen. The N-outflow of the sub-pool “Food and Feed Processing” from the production of food for human consumption and feed for agricultural livestock and pets totals 2684 kt  $\text{N a}^{-1}$ . The production quantities are provided in various tables of the Annual Statistics on Food, Agriculture and Forests (BMEL 2016). The main contributor in the “Nitrogen Chemistry” sub-pool is the synthesis of 2695 kt  $\text{N a}^{-1}$  of ammonia by means of the Haber-Bosch process. This is the starting quantity of  $\text{N}_r$  from which all further compounds containing nitrogen in the chemical and consumer goods industry are produced. Nearly half of this (1274 kt  $\text{N a}^{-1}$ ) is used for the production of mineral fertiliser. The main source of statistics on production in the manufacturing sector in Germany is the Production Survey (DESTATIS 2017a). However, this is not very well suited to

our purposes. One problem is that the Production Survey does not clearly distinguish between precursor products and end products, which leads to double counting. In addition, many details are not disclosed for reasons of data protection. This results in a considerable discrepancy in the balance. The N-flow with chemicals and (intermediate) products from the sub-pool “Nitrogen Chemistry” into the third sub-pool “Other Producing Industry” is 1356 kt N a<sup>-1</sup>, whereas the N-flow with the resultant consumer goods for sale to consumers according to the Production Survey is only 166 kt N a<sup>-1</sup>.

The “Humans and Settlements” pool contains N-flows totalling 985 kt N a<sup>-1</sup> that are associated with nutrition, housing, households, and domestic consumption. Imports and exports of food, feed and consumer goods are already included in the pool “Material and Products in Industry”, and there are no further trans-boundary N-flows into or out of the private sector. The N-outflows from this pool are mainly contained in sewage and waste from the households.

The “Agriculture” pool is a central element of the nitrogen budget, accounting for the largest quantities of reactive nitrogen released into the environment. The figures for N-flows in this case are mostly taken from the National Nitrogen Budget of BMEL. The outflows from the “Agriculture” pool are set equal to the inflows of 3320 kt N a<sup>-1</sup>, with the N-outflows into the “Hydrosphere” pool taken to be the difference between the total inflows and the other calculated outflows. Including the N-flows between the sub-pools “Animal Husbandry”, “Soil Management”, and “Biogas Production”, the nitrogen turnover within agriculture is ~6500 kt N a<sup>-1</sup>. As a preliminary estimate, the depletion of N-stocks in the agriculturally used mineral soils and organic soils could be in the order of 500 kt N a<sup>-1</sup>. However, in view of the considerable uncertainty, this value is not considered for inclusion in the N-budget.

The “Forest and semi-natural vegetation” pool comprises the N-flows in natural and near-natural ecosystems apart from agriculture. The N-flows associated with wood removals and wood use are based on the report of the Thünen Institute (2016a). The N-inflow of 310 kt N a<sup>-1</sup> is small in comparison with the other pools. The depletion of the N-stock of 293 kt N a<sup>-1</sup> in the forest soils is not taken into consideration.

The “Waste” pool includes the N-flows occurring with the collection, treatment, and disposal of solid waste and wastewater. However, it is not possible to draw reliable conclusions from the statistics regarding the material flows from the primary waste materials through the various stages of sorting and treatment, the recycling of materials, until final disposal (waste depots, incineration). Furthermore, only rough estimates could be made of the nitrogen contents of the various types of waste. The figures of 345 kt N a<sup>-1</sup> as input and 732 kt N a<sup>-1</sup> as solid waste output are therefore only approximate estimates. In the “Wastewater” sub-pool there is a turnover of ~500 kt N a<sup>-1</sup>, although the N-inflow with sewage can only be estimated.

The “Hydrosphere” pool includes the N inputs and transported N quantities in groundwater (including the unsaturated zone), surface waters, and coastal seas. Key N-flows in the “Hydrosphere” are determined on the basis of the river basin management system MoRE (Modelling of Regionalized Emissions; Fuchs et al. 2017a). Of the total N inputs into the “Hydrosphere” of 1167 kt N a<sup>-1</sup>, nitrate leaching accounts for 857 kt N a<sup>-1</sup>, with nearly 90 % of this is attributable to agriculture. The “Hydrosphere” budget is based on the premise that the amount of NO<sub>3</sub><sup>-</sup> in the groundwater in Germany is constant over time, i.e. that inflow, denitrification, and outflow of nitrate are in dynamic equilibrium and there is thus no change in the NO<sub>3</sub><sup>-</sup> stock in the aquifer. On this basis, denitrification totalling 648 kt N a<sup>-1</sup> was calculated in the unsaturated zone (below the root zone), in groundwater and in surface waters. With the N-contents in surface waters, 500 kt N a<sup>-1</sup> leaves German territories and flows into the North Sea or Baltic Sea or to downstream neighbours.

Finally, “Trans-boundary N-flows” are the N<sub>r</sub> imports and N<sub>r</sub> exports for all pools, i.e. N-flows which originate or end outside Germany. The imports and exports are almost balanced (not including the N-flow with fuels). With the atmospheric transport of gaseous N<sub>r</sub> and the N-outflow in its waters,

Germany “exports” 744 kt N a<sup>-1</sup> of reactive nitrogen (NO<sub>3</sub>, NH<sub>3</sub>, NO<sub>x</sub>) to neighbouring countries or into the sea. (As a simplification, the N-discharges into coastal waters are also classed as exports, in contrast to the nitrogen flow scheme). Against this export of N<sub>r</sub> flows in the biosphere, there is an net import of 745 kt N a<sup>-1</sup> with products from food and feed processing and the chemical industry (excluding fuels). Agriculture imports in feed account for 405 kt N a<sup>-1</sup>, corresponding to some 20 % of the nitrogen (crude protein) in the total amount of animal feed. At the same time, Germany is also an exporter of unprocessed and processed agricultural produce (cereals, meat, dairy products), so that food and feed only accounts for a relatively small trade deficit of 269 kt N a<sup>-1</sup>.

An aim of the national balance of N-flows is to determine what amounts of reactive nitrogen are newly created every year or are brought into circulation, and how much of this N<sub>r</sub> is reduced or oxidised to molecular nitrogen (N<sub>2</sub>). Of the annual total of 6275 kt “fresh” N<sub>r</sub>, some 43 % is the result of ammonia synthesis (Haber-Bosch process). Domestic extraction of fossil fuels or net import of fuels containing nitrogen (lignite, coal, crude oil) make a similar contribution. The combustion of this fuel results in the formation of ~192 kt N a<sup>-1</sup> of thermal NO<sub>x</sub>. Nitrogen fixation in soils totalling 308 kt N<sub>r</sub> a<sup>-1</sup>, accounts for only about 5 % of the total N<sub>r</sub> increase. The most important reductions in reactive nitrogen are made in the energy sector, where molecular nitrogen is released by flue gas denoxing plants after the conversion of 1893 kt N<sub>r</sub> a<sup>-1</sup> from the combustion of fuels and a further 818 kt N<sub>r</sub> a<sup>-1</sup> from the refining of crude oil. Denitrification in waters, soils, and wastewater treatment plants totalling 1107 kt N a<sup>-1</sup> accounts as a natural process for some 24 % of the conversion of N<sub>r</sub> into molecular N<sub>2</sub>. With chemical products and food and feed, 744 kt N a<sup>-1</sup> (net) are imported, while 745 kt N a<sup>-1</sup> (net) are exported to neighbouring states or coastal seas via hydrosphere and atmosphere, so that the import-export budget in total is balanced.

Between the production (including extraction and net imports) of 6275 kt N a<sup>-1</sup> of reactive nitrogen annually and the reduction of 4648 kt N a<sup>-1</sup>, there is a difference of 1627 kt N a<sup>-1</sup>. This difference of 26 % (related to the N<sub>r</sub> production) can be interpreted in two ways:

- (i) The difference corresponds to the surplus in Germany’s National N budget, i.e. the amount of reactive N in the environment is increased annually by this amount (“accelerating the N-cascade”).
- (ii) The difference can be attributed to the uncertainties in determining N-flows as the result of inadequate statistics about goods flows and the N-contents of commodities, and the lack of knowledge about factors influencing the biochemical processes with which nitrogen is bound and denitrified.

When interpreting the results, these uncertainties should be taken into consideration. In order to obtain more reliable and updated values in future, the statistical data for N-flows must be improved, which will require the support of specialists from the relevant institutions.

However, despite these limitations, it can be concluded that the annual net release of reactive nitrogen in Germany is currently in the order of 1600 kt N a<sup>-1</sup>. There is a consensus that effective measures should be adopted as a matter of urgency in order to significantly reduce the amounts of reactive nitrogen emitted into the environment.

## 1 Introduction

The development of the Haber-Bosch process for industrial ammonia synthesis more than a century ago led to massive changes in the natural nitrogen cycle. As a result of growing agricultural production, the generation of energy from combustion processes, and transport, twice or three-times as much reactive nitrogen ( $N_r$ ) is now emitted into the environment as by natural processes, according to the estimates Galloway et al. (2008). Humans have had more impact on the nitrogen cycle than on any other geochemical cycle. The planetary boundaries for reactive nitrogen have clearly been exceeded (Steffen et al. 2015).

The inputs of reactive nitrogen into the environment lead to numerous problems which call for urgent solutions. These include the loss of aquatic and terrestrial biodiversity, harm to human health as a result of air pollution, the increased release of greenhouse gases with the known consequences for global climate warming, the loss of biodiversity due to increased N-depositions from the atmosphere, and also the pollution of groundwater and coastal ecosystems with nitrate. In Germany, there have been few or no signs of positive developments with regard to most of these environmental problems (UBA 2017a).

Nitrogen therefore represents a central issue for environmental policies, alongside climate change. Reviews of the situation and descriptions of the problems were provided by the background paper of the German Environment Agency on a multimedia nitrogen emissions reduction strategy (UBA 2009b), the European Nitrogen Assessment (Sutton et al. 2011), the special report of the German Advisory Council on the Environment on “Nitrogen: Strategies for resolving an urgent environmental problem” (SRU, 2015), the strategy paper “Reactive nitrogen in Germany” (UBA 2015), and the first nitrogen report of the German Federal Government (BMUB 2017). Salomon et al. (2016) also emphasise the need for an integrated nitrogen strategy for Germany.

A key precondition for such a strategy is knowledge of the relevant sources, sinks and flows of reactive nitrogen for the period under consideration. This is the remit of the investigation presented here, which aims to register the flows of the various  $N_r$ -species ( $NH_3/NH_4^+$ ,  $NO_3^-$ ,  $N_2O$ ,  $NO$ ,  $NO_2$ ,  $N_{org}$ ) that are emitted annually in Germany by the production and use of goods and by natural processes. Inflows and outflows of reactive nitrogen are determined for eight pools.

The calculation of nitrogen budgets was agreed internationally under the Gothenburg Protocol to the Convention on Long-Range Transboundary Air Pollution (CLTRAP). With the “Guidance document on national nitrogen budgets” (ECE 2013) the Expert Panel on Nitrogen Budgets (EPNB) of the Task Force on Reactive Nitrogen presented guidelines on formulating National Nitrogen Budgets (NNBs). First approaches for Germany were presented by UBA (2009a, 2009b, 2015).

A national budget for N-flows describes the eco-systemic nitrogen cascade (cf. Galloway et al. 2003; Leip et al. 2011) not only for agriculture, but also for the other sectors of the economy. Determining the N-flows between the sectors and the exchanges with the atmosphere and hydrosphere serves to address various questions, such as:

- ▶ How much reactive nitrogen is newly emitted every year?
- ▶ What quantities of emissions of the various  $N_r$  species are to be expected every year?
- ▶ What are the sources of this  $N_r$  and how is it generated?
- ▶ What happens to the  $N_r$ ? How much is converted back to molecular nitrogen ( $N_2$ ) by combustion processes or denitrification, how much is stored in sinks as organically bound nitrogen (e.g. in soils, waste landfill, or standing wood), and how much  $N_r$  remains in circulation in the biosphere, hydrosphere, and atmosphere where it can (potentially) cause environmental pollution?

- ▶ How reliable are the data used for estimating the quantities and flows? Are the  $N_r$  flows for Germany more or less in balance, or are there gaps in the data concerning the origins and/or fate of  $N_r$  either overall or for individual N-species?



## 2 Flows of reactive nitrogen in Germany – An overview

### 2.1 Nitrogen pools, sub-pools and nitrogen flows

The approach used to determine nitrogen-flows for Germany are based on the “Guidance document on national nitrogen budgets” (ECE 2013). The following terms are adopted:

- ▶ *Reactive nitrogen ( $N_r$ )* is nitrogen in any form that is relatively easily available for organisms, e.g. ammonia/ammonium ( $\text{NH}_3/\text{NH}_4^+$ ), nitrogen oxides ( $\text{NO}$ ,  $\text{NO}_2$ , referred to jointly as  $\text{NO}_x$ ), nitrous oxide ( $\text{N}_2\text{O}$ ), nitrate ( $\text{NO}_3^-$ ), and organically bound nitrogen ( $N_{\text{org}}$ ) in soil, plants, and animals, as well as in food, animal feed, industrial products, etc.
- ▶ *Pools* are elements in the nitrogen budget which serve to store relevant quantities of reactive nitrogen and exchange this via nitrogen flows with other pools. Pools can be environmental media (atmosphere, hydrosphere), economic sectors (industry, agriculture) or forms of land use (forests and areas of semi-natural vegetation).
- ▶ *Sub-pools* Pools can be sub-divided if sufficient data are available, so that internal N-flows between sub-units of the pool can be quantified. Sub-pools are the smallest units for which incoming and outgoing N-flows can be registered (as well as any changes in stocks).
- ▶ *N-flows* describe the transport over time of the reactive N-species between the pools or sub-pools (in our case for the territories of the Federal Republic of Germany including coastal waters), as well as trans-boundary imports and exports, as well as the sources, sinks, and changes in stocks of  $N_r$ . The transformation of molecular nitrogen ( $\text{N}_2$ ) to reactive nitrogen (by ammonia synthesis, biological N-fixing, or by combustion processes) and the reverse process (denitrification) are also included as nitrogen flows.

The pools and sub-pools are oriented mainly on the structure of the sectors used by IPCC and UNFCCC for the national greenhouse gas emissions inventory (IPCC 2006; EEA 2013). Pools are given a two-letter Pool-ID, with a further two-letter ID for the sub-pools (Tab. 2-1). The NNB for Germany uses the IDs of the NNB Annex 0 (ECE 2013). Sub-sub-pools, as proposed in ECE (2013), are not used here for reasons of clarity.

The N-flows between pools or sub-pools are coded in the form: **AB.CD-EF.GH-matrix**, with

|        |  |
|--------|--|
| AB.CD  | Pool.Sub-pool is the source of the N-flow (Pool(ex)) |
| EF.GH  | Pool.Sub-pool to which the N-flow goes (Pool(in))    |
| matrix | Transport matrix, medium, flow of goods.             |

The ending “-matrix” is explained in Tab. 2-2.

Table 2-1: Pools and sub-pools of the National Nitrogen Balance for Germany (after ECE 2013, with adaptations).

| Pool / Sub-pool ID | Term in the NNB Annexes (ECE 2013)  | Chapter |
|--------------------|---|---------|
| <b>AT</b>          | <b>Atmosphere</b>   | 3       |
| <b>EF</b>          | <b>Energy and Fuels<sup>a</sup></b>   | 4       |
| EF.EC              | Energy and Fuels - Energy Conversion  | 4.1     |
| EF.IC              | Energy and Fuels - Manufacturing Industries and Construction                          | 4.2     |
| EF.TR              | Energy and Fuels - Transport  | 4.3     |
| EF.OE              | Energy and Fuels - Other Energy and fuels   | 4.4     |
| <b>MP</b>          | <b>Materials and Products in Industry</b>   | 5       |
| MP.FP              | Materials and Products in Industry – Food and feed Processing                         | 5.1     |
| MP.NC <sup>a</sup> | Materials and Products in Industry - Nitrogen Chemistry <sup>b</sup>                  | 5.2     |
| MP.OP              | Materials and Products in Industry - Other Producing industry                         | 5.3     |
| <b>HS</b>          | <b>Humans and Settlements</b>   | 6       |
| HS.HB <sup>b</sup> | Humans and Settlements – Human Body <sup>c</sup>                                      | 6.1     |
| HS.MW              | Humans and Settlements – Material World   | 6.2     |
| <b>AG</b>          | <b>Agriculture</b>  | 7       |
| AG.AH              | Agriculture – Animal Husbandry <sup>d</sup>   | 7.1     |
| AG.SM              | Agriculture – Soil Management   | 7.2     |
| AG.BG <sup>b</sup> | Agriculture – Biogas Production<br>(no equivalent sub-pool is defined in NNB Annex 6) | 7.3     |
| <b>FS</b>          | <b>Forest and Semi-natural vegetation</b>   | 8       |
| FS.FO              | Forest and Semi-natural vegetation - Forest   | 8.1     |
| FS.OL              | Forest and Semi-natural vegetation – Other land                                       | 8.2     |
| FS.WL              | Forest and Semi-natural vegetation – Wetland  | 8.3     |
| <b>WS</b>          | <b>Waste<sup>a</sup></b>  | 9       |
| WS.SW              | Waste – Solid Waste   | 9.1     |
| WS.WW              | Waste – Wastewater  | 9.2     |
| <b>HY</b>          | <b>Hydrosphere</b>  | 10      |
| HY.GW              | Hydrosphere - Groundwater   | 10.1    |
| HY.SW              | Hydrosphere – Surface Water   | 10.2    |
| HY.CW              | Hydrosphere – Coastal Water   | 10.3    |
| <b>RW</b>          | <b>Rest of the World<sup>e</sup>, trans-boundary nitrogen flows</b>                   | 11      |

<sup>a</sup> At the time of writing, the final versions of the NNB annexes for “Energy and Fuels” (Annex 1) and “Waste” (Annex 5) were not yet available.

<sup>b</sup> ECE (2013) Annex 2 uses MP.CI as “Materials and Products - Chemical Industry”.

<sup>c</sup> Also includes “Organic world” and “Non-agricultural animals (pets)” of ECE (2013).

<sup>d</sup> Also includes “Manure management and storage” of ECE (2013).

<sup>e</sup> “Trans-boundary nitrogen flows” are not a pool in their own right in ECE (2013).

In Chapters 3 to 11, the results are presented for the eight pools and the trans-boundary nitrogen flows.

Table 2-2: Flow code suffixes for matrices or transport processes.

| Flow code  | Matrix                        | Description   |
|------------|-------------------------------|---|
| -abstr     | Water                         | Groundwater abstraction for drinking water supply   |
| -animProd  | Animal products               | Products from holding agricultural livestock (milk, meat, eggs, wool, leather)                                |
| -atmDep    | Air                           | Atmospheric N-deposition ( $\text{NO}_x$ , $\text{NH}_y$ )  |
| -compost   | Compost                       | Compost (from settlement waste)   |
| -cosub     | Biomass                       | Co-substrate of non-agricultural origins for biogas plants  |
| -crop      | Vegetable biomass             | Harvested agricultural crops  |
| -digest    | Digestate                     | Digestate from anaerobic digesters  |
| -discharge | Water                         | Water flows into surface waters and groundwater; discharges of (treated) wastewater from treatment plants     |
| -feed      | Feed                          | Feed for agricultural livestock and pets  |
| -fish      | Fish                          | Fish products (from fishing and aquaculture)  |
| -food      | Food                          | Food for human consumption  |
| -fuel      | Crude oil; fuel               | Crude oil, coal, lignite, and other fuel  |
| -gasEm     | Air                           | Emissions of gaseous N-compounds ( $\text{NH}_3$ , $\text{NO}_x$ , $\text{N}_2\text{O}$ ) into the atmosphere |
| -gasN      | Air                           | Gaseous $\text{N}_r$ -compounds in the atmosphere ( $\text{NH}_3$ , $\text{NO}_x$ , $\text{N}_2\text{O}$ )    |
| -irrig     | Water                         | Irrigation (groundwater and surface water)  |
| -leach     | Water                         | Nitrate leachate  |
| -manure    | Manure                        | Manure from animal husbandry (including slurry, liquid manure and dry faeces)                                 |
| -minFert   | Mineral fertiliser            | Nitrogenous mineral fertiliser  |
| -N2        | Air                           | Denitrification and release of $\text{N}_2$   |
| -Nfix      | Biomass                       | Symbiotic nitrogen fixing in soils  |
| -orgFert   | Organic fertiliser            | Nitrogenous organic fertiliser  |
| -prod      | Industrial and consumer goods | Industrial products containing nitrogen (interim products) and consumer goods (non-food)                      |
| -runoff    | Water                         | Lateral water run-off, including soil erosion and outflow from drainage systems                               |
| -seed      | Plants                        | Seed and planting material in agriculture   |
| -sewage    | Wastewater                    | Wastewater (sewage and stormwater) from households and industry   |
| -sludge    | Sludge                        | Sludge from wastewater treatment  |
| -waste     | Waste                         | Industrial and settlement waste   |
| -wood      | Wood                          | Removals (from forests) and use of wood   |

Each chapter begins with an overview of the N-flows for the pool. In these tables (Tab. 3-1, 4-1, etc.) all nitrogen inflows are given for the pool or sub-pool, followed by the nitrogen outflows, in each case in the order in Tab. 2-1. Column 5 of the table gives the N<sub>r</sub> species that is transported with the matrix in question. Column 6 shows the chapter or section in which the calculation of the N-flow is discussed.

## 2.2 Determining nitrogen flows

The N-flows are either taken from published statistics or are calculated as follows:

N-flow (kt N a<sup>-1</sup>) =

Transported/converted matrix (t a<sup>-1</sup>) x mean N-content (kg N t<sup>-1</sup>) x 10<sup>-6</sup>.

Transport media (matrices) are air, water, biomass (e.g. vegetable or animal farm produce) and industrial products (e.g. mineral fertiliser, plastics, or consumer goods). The reference period is usually the calendar years from 2010 to 2014, for which the N-flows are determined. The chapter or section in which the data sources or the calculations are discussed is given in Column 6 of the introductory table for each pool.

As far as possible, the nitrogen flows or the amounts of materials that are transported/transformed together with their nitrogen contents are taken from official statistics and reports. This applies in particular for documents which use established and well-documented calculation methodologies or models, and where the results provide reference values in the environmental policy debate at the national or international level. Relevant sources cover:

- ▶ Emissions of climate-relevant N-compounds and air pollutants: German reports on atmospheric emissions (UBA 2016a, 2017b)
- ▶ Gaseous emissions from agriculture: Thünen Report 46 (Rösemann et al. 2017)
- ▶ Atmospheric depositions (NH<sub>y</sub>, NO<sub>x</sub>): Model LOTOS-EUROS (UBA-Project PINETI-3; Schaap et al. 2018)
- ▶ Nitrogen budget for agriculture in Germany (BMEL 2018)
- ▶ N discharges into surface waters and groundwater: MoRE model (Fuchs et al. 2017a).

The nitrogen flows considered, and the allocation of statistical data is oriented as a rule on the structure and the contents of the statistics in question. For each pool, an overview table at the end of the chapter lists all the N-flows that have been taken into account. The threshold for inclusion is as a rule a N-flow of 1 kt N per year (although for reasons of completeness, smaller N-flows are occasionally included).

Ideally the nitrogen budget for each pool and for the national budget as a whole should be balanced:

$$\sum N(\text{Inflows}) - \sum N(\text{Outflows}) \pm \Delta\text{Stock} = 0.$$

However, this is not always the case. There can be various reasons for this:

- ▶ Gaps, errors, or inconsistencies in the statistical data on N-flows (natural quantities of the matrix), or on changes in stocks
- ▶ N-flows that have not been included
- ▶ Uncertainties in the data or natural fluctuations in the (mean) N-contents in the transported matrix
- ▶ Gaps in our knowledge about specific N-transformation processes.

Larger discrepancies for a pool are an indication that the results should be interpreted with caution, and that there is a need to improve the basis on which the calculations were made.

## 2.3 Range of uncertainty

When interpreting and evaluating the results for N-flows, then in addition to the absolute values it is also important to consider the quality or the uncertainty of the data used in the calculations. Figures for material flows (quantity structure) are based as a rule on statistical sources and the methodologies that have been used will introduce inaccuracies into the calculations, and differences regarding the allocations to the various material flows (matrices) auf. For the N-contents in the matrices, values frequently differ from source to source. For some N-flows, no reliable data is available, and in such cases values had to be estimated.

In the NNB Annex 0, Table 5 (ECE 2013), four levels of uncertainty are proposed (Tab. 2-3). Each level is also given a quantitative uncertainty factor. However it is not clear how this is to be interpreted, i.e. whether it is a minimum-maximum range, a confidence interval, a relative standard error, or some other measure of error for the (unknown) true value of the relevant N-flow.

Table 2-3: Uncertainty ranges of N-flows (adapted from NNB Annex 0, Table 5).

| Level | Uncertainty range <sup>a</sup> ca. | Level    | Description; sources   |
|-------|------------------------------------|----------|--|
| 1     | 0.9 ... 1.1                        | Very low | Current official statistics; measurements; details in the literature (referenced); values only differ slightly between sources |
| 2     | 0.67 ... 1.5                       | Low      | Non-official statistics; Industry reports; Expert estimates; values show more differences between sources                      |
| 3     | 0.5 ... 2.0                        | Medium   | Internet (online) values; non-referenced data in the literature, values differ considerably between sources                    |
| 4     | < 0.5 ... > 2                      | High     | Based on assumptions, rough estimates; values in some cases are placeholders   |

<sup>a</sup> Semi-quantitative estimate of the range in which the actual value probably lies (not a statistical confidence interval).

The uncertainty levels for N-flows are rated as shown in Tab. 2-3. In most cases these are our subjective assessments, and only a few assessments of uncertainty could be taken from the literature.

Note that for uniformity of presentation, the values for the N-flows are expressed to one decimal place, irrespective of the order of magnitude of the flow and the level of uncertainty involved. However, results with “medium” or “high” levels of uncertainty will at best be accurate to two significant digits.

### 3 Atmosphere (AT)

The “Atmosphere” pool (Pool 7 in ECE 2016) includes the exchanges (emissions and depositions) of nitrogen compounds in gaseous form between the atmosphere and the other pools (see Tab. 3-1). The atmosphere serves primarily as transport medium and is not divided into sub-pools. Nitrogen is present in the atmosphere to a very large extent in its inert molecular form (N<sub>2</sub>), but only the flows of reactive N-forms are quantified. Conversions between the various forms of nitrogen are not considered, with the exceptions of the biological fixation of molecular nitrogen to form organic N-compounds in soils, and the formation of NO<sub>x</sub> by lightning, for which the “Atmosphere” pool represents the source. Conversely, there are nitrogen inflows into the atmosphere with denitrification in soils and waters to release N<sub>2</sub>.

Table 3-1: Inflows (Pool(in)) and outflows (Pool(ex)) of N<sub>r</sub> in the “Atmosphere” pool.

| Pool(ex)                           | Pool(in) | Flow code               | Description  | N-species                          | Chapter |
|------------------------------------|----------|-------------------------|--|------------------------------------|---------|
| <b>Emissions in the atmosphere</b> |          |                         |  |                                    |         |
| EF.EC                              | AT       | EF.EC-AT-gasEm          | NO <sub>x</sub> , N <sub>2</sub> O emissions from Energy Conversion                              | NO <sub>x</sub> , N <sub>2</sub> O | 3.2.1   |
| EF.EC                              | AT       | EF.EC-AT-gasEm          | NH <sub>3</sub> emissions from Energy Conversion   | NH <sub>3</sub>                    | 3.3     |
| EF.IC                              | AT       | EF.IC-AT-gasEm          | NO <sub>x</sub> , N <sub>2</sub> O emissions from Manufacturing and Construction                 | NO <sub>x</sub> , N <sub>2</sub> O | 3.2.1   |
| EF.IC                              | AT       | EF.IC-AT-gasEm          | NH <sub>3</sub> emission from Manufacturing and Construction                                     | NH <sub>3</sub>                    | 3.3     |
| EF.TR                              | AT       | EF.TR-AT-gasEm          | NO <sub>x</sub> , N <sub>2</sub> O emissions from Transport                                      | NO <sub>x</sub> , N <sub>2</sub> O | 3.2.1   |
| EF.TR                              | AT       | EF.TR-AT-gasEm          | NH <sub>3</sub> emissions from Transport   | NH <sub>3</sub>                    | 3.3     |
| EF.OE                              | AT       | EF.OE-AT-gasEm          | NO <sub>x</sub> and N <sub>2</sub> O emissions from Other Energy and Fuels                       | NO <sub>x</sub> , N <sub>2</sub> O | 3.2.1   |
| EF.OE                              | AT       | EF.OE-AT-gasEm          | NH <sub>3</sub> emissions from Other Energy and Fuels  | NH <sub>3</sub>                    | 3.3     |
| MP.NC                              | AT       | MP.NC-AT-gasEm          | NO <sub>x</sub> , N <sub>2</sub> O emissions from Nitrogen Chemistry                             | NO <sub>x</sub> , N <sub>2</sub> O | 3.2.1   |
| MP.OP                              | AT       | MP.OP-AT-gasEm          | NO <sub>x</sub> , N <sub>2</sub> O emissions from Other producing industry                       | NO <sub>x</sub> , N <sub>2</sub> O | 3.2.1   |
| HS.MW                              | AT       | HS.MW-AT-gasEm          | NO <sub>x</sub> , N <sub>2</sub> O emissions from urban areas (LULCC) <sup>b</sup>               | NO <sub>x</sub> , N <sub>2</sub> O | 3.2.1   |
| HS.HB                              | AT       | HS.HB-AT-gasEm          | NH <sub>3</sub> emitted by humans  | NH <sub>3</sub>                    | 6.1     |
| AG.AH                              | AT       | AG.AH-AT-gasEm          | NO <sub>x</sub> , N <sub>2</sub> O emissions from Animal husbandry (including manure management) | NO <sub>x</sub> , N <sub>2</sub> O | 3.2.1   |
| AG.AH                              | AT       | AG.AH-AT-gasEm          | NH <sub>3</sub> emission from housing and storage of manure                                      | NH <sub>3</sub>                    | 3.3     |
| AG.SM                              | AT       | AG.SM-AT-gasEm          | NO <sub>x</sub> , N <sub>2</sub> O emissions from Soil Management                                | NO <sub>x</sub> , N <sub>2</sub> O | 3.2.1   |
| AG.SM                              | AT       | AG.SM-AT-gasEm          | NH <sub>3</sub> emissions from the application of mineral and organic fertiliser                 | NH <sub>3</sub>                    | 3.3     |
| AG.SM                              | AT       | AG.SM-AT-N <sub>2</sub> | Denitrification of utilised agricultural mineral soils and organic soils                         | N <sub>2</sub>                     | 7.2.3   |
| AG.BG                              | AT       | AG.BG-AT-gasEm          | NO <sub>x</sub> , N <sub>2</sub> O emissions from biogas production                              | NO <sub>x</sub> , N <sub>2</sub> O | 3.2.1   |
| AG.BG                              | AT       | AG.BG-AT-gasEm          | NH <sub>3</sub> emissions from biogas production   | NH <sub>3</sub>                    | 3.3     |
| FS.FO                              | AT       | FS.FO-AT-gasEm          | NO <sub>x</sub> , N <sub>2</sub> O emissions from forest areas (LULCC)                           | NO <sub>x</sub> , N <sub>2</sub> O | 3.2.1   |
| FS.FO                              | AT       | FS.FO-AT-N <sub>2</sub> | Denitrification in forest soils  | N <sub>2</sub>                     | 8.1.3   |
| FS.OL                              | AT       | FS.OL-AT-N <sub>2</sub> | Denitrification in semi-natural areas  | N <sub>2</sub>                     | 8.2.2   |
| FS.WL                              | AT       | FS.WL-AT-gasEm          | NO <sub>x</sub> , N <sub>2</sub> O emissions from wetlands (LULCC)                               | NO <sub>x</sub> , N <sub>2</sub> O | 3.2.1   |

| Pool(ex) | Pool(in) | Flow code      | Description  | N-species  | Chapter |
|----------|----------|----------------|--|--|---------|
| FS.WL    | AT       | FS.WL-AT-N2    | Denitrification in wetlands  | N2   | 8.3.3   |
| WS.SW    | AT       | WS.SW-AT-gasEM | NO <sub>x</sub> , N <sub>2</sub> O emissions from waste incineration plants and waste disposal sites | NO <sub>x</sub> , N <sub>2</sub> O                   | 3.2.1   |
| WS.WW    | AT       | WS.WW-AT-gasEM | NO <sub>x</sub> and N <sub>2</sub> O emissions from wastewater treatment plants                      | NO <sub>x</sub> , N <sub>2</sub> O                   | 3.2.1   |
| WS.WW    | AT       | WS.WW-AT-N2    | Denitrification in Wastewater treatment plants   | N2   | 9.2.4   |
| HY.GW    | AT       | HY.GW-AT-N2    | Denitrification in the unsaturated zone and in groundwater   | N2   | 10.1.2  |
| HY.SW    | AT       | HY.SW-AT-N2    | Denitrification in surface waters  | N2   | 10.2.2  |
| RW       | AT       | RW-AT-gasN     | Transboundary imports of gaseous N-compounds   | NH <sub>y</sub> , NO <sub>x</sub> , N <sub>2</sub> O | 3.5     |

#### N-depositions from the atmosphere and N-fixing

|    |       |                 |   |  |       |
|----|-------|-----------------|---|--|-------|
| AT | HS.MW | AT-HS.MW-atmDep | Atmospheric N-deposition on settlement areas              | NH <sub>y</sub> , NO <sub>x</sub>                    | 3.4   |
| AT | AG.SM | AT-AG.SM-atmDep | Atmospheric N-deposition on agricultural areas            | NH <sub>y</sub> , NO <sub>x</sub>                    | 3.4   |
| AT | AG.SM | AT-AG.SM-Nfix   | Biological nitrogen fixing in utilised agricultural areas | N(org)   | 7.2.1 |
| AT | FS.FO | AT-FS.FO-atmDep | Atmospheric N-deposition on forest areas                  | NH <sub>y</sub> , NO <sub>x</sub>                    | 3.4   |
| AT | FS.FO | AT-FS.FO-Nfix   | Biological nitrogen fixing in forest soils                | N(org)   | 8.1.2 |
| AT | FS.OL | AT-FS.OL-atmDep | Atmospheric N-deposition on semi-natural areas            | NH <sub>y</sub> , NO <sub>x</sub>                    | 3.4   |
| AT | FS.OL | AT-FS.OL-Nfix   | Biological nitrogen fixing in semi-natural areas          | N(org)   | 8.2.1 |
| AT | FS.WL | AT-FS.WL-atmDep | Atmospheric N-deposition on Wetland                       | NH <sub>y</sub> , NO <sub>x</sub>                    | 3.4   |
| AT | FS.WL | AT-FS.WL-Nfix   | Biological nitrogen fixing in Wetland                     | N(org)   | 8.3.1 |
| AT | HY.SW | AT-HY.SW-atmDep | Atmospheric N-deposition on surface waters                | NH <sub>y</sub> , NO <sub>x</sub>                    | 3.4   |
| AT | HY.CW | AT-HY.CW-atmDep | Atmospheric N-deposition on coastal waters                | NH <sub>y</sub> , NO <sub>x</sub>                    | 3.4   |
| AT | RW    | AT-RW-gasN      | Transboundary exports of gaseous N-compounds              | NH <sub>y</sub> , NO <sub>x</sub> , N <sub>2</sub> O | 3.5   |

LULCC: Land Use and Land Cover Change; N<sub>2</sub>O emissions as a result of land cover changes and humus depletion

Note: In contrast to biological nitrogen fixing, the transformation of N<sub>2</sub> to reactive nitrogen compounds in the form of mineral nitrogen fertiliser and other nitrogenous chemical products by means of ammonia synthesis (Haber-Bosch process) is not treated as a N-flow from the atmosphere, but as N<sub>r</sub> input from sub-pool “Nitrogen Chemistry” (MP.NC).

### 3.1 Land use in Germany

Atmospheric N<sub>r</sub> emissions and ambient pollution levels depends among other things on the land use or the land cover (vegetation types, constructions, etc.). For Germany, various data sources are available on land use, but these differ in terms of the land use definitions and land cover categories they use, the way in which they collect data, the reference periods, and the scale and the spatial resolution (cf. Arnold 2015). Relevant sources here are the Basis DLM, the LBM-DE2012, the CLC2012 map (for details, cf. NIR, UBA 2016a) and the area statistics (DESTATIS, various years).

The Basis Digital Landscape Model (Basis-DLM) forms the basis for Germany’s Topographic-Cartographic Information System (ATKIS®) of the Working Committee of the Surveying Authorities of the



Laender of the Federal Republic of Germany (AdV). ATKIS® describes the surface of Germany by means of digital landscape and topographic models.

In the Digital Land Cover Model for Germany (LBM-DE2012), the land cover and land use information on the Basis DLM is converted into a classification system which makes it possible to directly derive the land cover and land use classes in accordance with the nomenclature of the pan-European CORINE Land Cover (CLC) data-set. The land cover is updated on the basis of satellite data; the CLC-class is then determined from the combination of land cover/land use information. The minimum cartographic unit is 1 ha and the minimum mapping width of the LBM-DE objects is 15 m (cf. [www.bkg.bund.de/SharedDocs/Downloads/BKG/EN/Downloads-EN-Flyer/BKG-Remote-Sensing-EN.pdf?\\_\\_blob=publicationFile&v=2](http://www.bkg.bund.de/SharedDocs/Downloads/BKG/EN/Downloads-EN-Flyer/BKG-Remote-Sensing-EN.pdf?__blob=publicationFile&v=2)).

In CLC2012 (10 ha), objects of LBM-DE2012 are aggregated to sizes greater than 10 ha (with a minimum mapping width for an object of 15 m).

The Land Survey of types of land use of the Federal Statistical Agency evaluates the information for each calendar year from the Official Cadastral Information System (ALKIS®) and until 2015 from the Automated Land Register (ALK).

Surveys are also carried out for specific land uses. The Federal and Laender Statistical Agencies regularly conduct a questionnaire-based census of the utilised agricultural areas of all registered agricultural businesses (above a minimum size). Forest areas are evaluated on the basis of remote sensing data as part of the GSE Forest Monitoring project (Oehmichen et al. 2011).

Land use and land cover information from the various sources is based on different data and classification systems. For the evaluation of reports for the greenhouse gas emissions inventory (NIR; UBA 2016a; corresponding to the IPCC categories in Tab. 3-2) or for the calculation of atmospheric deposition in Germany (PINETI-3, Schaap et al. 2018) it is also necessary to merge land use or land cover classes, leading to further differences between the areas reported.

For the calculation of the area-related N-flows in Germany, use is made of the land use classes and areas according to CLC2012 (10 ha) (see Tab. 3-2). The CLC land cover classifications are preferred because: (i) These areas are also used for the greenhouse gas emissions inventory; (ii) The classification is based on satellite images, i.e. on the actual cover/use; (iii) The receptor types of the N-deposition modelling (PINETI-3, Schaap et al. 2018) refer to these use classes; and (iv) The land cover classification is more differentiated than in the ATKIS system or the land use statistics of the Federal Statistical Agency (e.g. with a distinction between deciduous, pine and mixed forests; arable land and grassland).

Tables 3-2 and 3-3 show that the classes and categories of the various classification systems are only comparable to a limited extent, and that even where there is broad consensus about the definitions of types of use (e.g. for “forest” or “agricultural area”) there can still be appreciable differences in the data on areas.

Table 3-2: CORINE Land Cover classes, grouped under IPCC-Land use categories (NIR, UBA 2016a; Tab. 321) with corresponding receptor types of deposition modeling project PINETI-3 (Schaap et al. 2018).

| IPCC-Categories<br>CORINE Land Cover classes                                  | CLC-Code | Area <sup>b</sup><br>ha       | Area <sup>b</sup><br>% | Receptor type <sup>a</sup> |
|---|----------|-------------------------------|------------------------|----------------------------|
| <b>Settlements</b>  |          | <b>3,376,347</b>              | <b>9.32 %</b>          |                            |
| Urban fabric  | 111, 112 | 2,485,819                     | 6.86 %                 | urb                        |
| Industry, commerce, infrastructure  | 121-124  | 565,287                       | 1.56 %                 | urb                        |
| Mines, dumps, spoil heaps   | 131-133  | 90312                         | 0.25 %                 | urb                        |
| Green urban areas, Sport and leisure facilities                               | 141, 142 | 234,929                       | 0.65 %                 | grs                        |
| <b>Arable land</b>  |          | <b>13,926,559</b>             | <b>38.43 %</b>         |                            |
| Non-irrigated arable land   | 211      | 13,586,776                    | 37.49 %                | ara                        |
| Vineyards   | 221      | 123,680                       | 0.34 %                 | crp                        |
| Orchards and berry plantations  | 222      | 151,420                       | 0.42 %                 | crp                        |
| Complex cultivation patterns  | 242      | 64,683                        | 0.18 %                 | ara                        |
| <b>Grassland</b>  |          | <b>6,855,430</b>              | <b>18.92 %</b>         |                            |
| Pastures  | 231      | 6,453,952                     | 17.81 %                | grs                        |
| Land used mainly for agriculture with significant areas of natural vegetation | 243      | 88,638                        | 0.24 %                 | ara/crp <sup>d</sup>       |
| Natural grasslands  | 321      | 152,012                       | 0.42 %                 | grs                        |
| Moors and heathland   | 322      | 97,070                        | 0.27 %                 | sem                        |
| Inland marshes  | 411      | 37,877                        | 0.10 %                 | dec/wat <sup>d</sup>       |
| Salt marches  | 421      | 25,881                        | 0.07 %                 | wat/oth <sup>d</sup>       |
| <b>Forests</b>  |          | <b>11,077,730</b>             | <b>30.57 %</b>         |                            |
| Broad-leaved forests  | 311      | 3,476,917                     | 9.59 %                 | dec                        |
| Coniferous forests  | 312      | 5,922,839                     | 16.34 %                | cnf                        |
| Mixed forests   | 313      | 1,453,477                     | 4.01 %                 | mix                        |
| Transitional woodland/scrub   | 324      | 224,497                       | 0.62 %                 | sem                        |
| <b>Other land</b>   |          | <b>110,765</b>                | <b>0.31 %</b>          |                            |
| Beaches, dunes, sands   | 331      | 16,231                        | 0.04 %                 | oth                        |
| Rocky areas without vegetation  | 332      | 11,059                        | 0.03 %                 | oth                        |
| Areas with sparse vegetation  | 333      | 8,680                         | 0.02 %                 | oth                        |
| Glaciers/perpetual snow   | 335      | 34                            | 0.00 %                 | wat                        |
| Peat bogs   | 412      | 74,761                        | 0.21 %                 | grs/wat <sup>d</sup>       |
| <b>Wetlands</b>   |          | <b>584,438</b>                | <b>2.46 %</b>          |                            |
| Intertidal flats <sup>c</sup>   | 423      | (307,628)                     | 0.85 %                 | Wat                        |
| Water courses   | 511      | 75,518                        | 0.21 %                 | wat                        |
| Water bodies  | 512      | 346,459                       | 0.96 %                 | wat                        |
| Lagoons   | 521      | 116,658                       | 0.32 %                 | wat                        |
| Estuaries   | 522      | 45,803                        | 0.13 %                 | wat                        |
| Sea and ocean <sup>c</sup>  | 523      | (2,007,973)                   | --                     |                            |
| <b>Total</b>  |          | <b>36,238,897<sup>e</sup></b> | <b>100 %</b>           |                            |

<sup>a</sup> Vegetation classes (Receptor type) of the LOTOS-EUROS-Modelling of atmospheric N-depositions (Schaap et al. 2018), cf. Tab. 3-6.

<sup>b</sup> Areas according to CLC 2012 (10 ha MCU).

<sup>c</sup> Area not taken into consideration when determining N-flows.

<sup>d</sup> Mean deposition for both receptor types.

<sup>e</sup> Total including CLC-Class 423, without Class 523.

Table 3-3: A comparison of area data and types of use

| CORINE Land Cover (10 ha)<br>(2012)                                   |                            | DESTATIS Land Survey<br>(31.12.2012)  |                            | Agricultural<br>Census<br>(2010) | National<br>Forest<br>Inventory<br>(2012) |
|---|----------------------------|---|----------------------------|----------------------------------|---|
| Land cover class <sup>a</sup>   | Area<br>(km <sup>2</sup> ) | Type of use   | Area<br>(km <sup>2</sup> ) | Area<br>(km <sup>2</sup> )       | Area<br>(km <sup>2</sup> )                |
| Urban fabric, transport,<br>dump sites                                | 33,763                     | Buildings and open<br>spaces, industrial or<br>transport units, other<br>uses (without wasteland) | 50,479                     |                                  |   |
| Agricultural areas  | 203,805                    | Agricultural area<br>(excluding moor, heath)  | 183,532                    | 167,040 <sup>b</sup>             |   |
| Peat bogs   | 748                        | Moor  | 844                        |                                  |   |
| Moors and heathland   | 971                        | Heath   | 607                        |                                  |   |
| Forest  | 110,777                    | Forest areas  | 108,909                    |                                  | 114,190 <sup>c</sup>                      |
| Water bodies (without<br>peat bogs) <sup>d</sup>                      | 5,844                      | Surface waters  | 8,420                      |                                  |   |
| Natural grassland, salt<br>marshes, wetlands,<br>woodland, other land | 3,404                      | Infertile land  | 4,379                      |                                  |   |
| <b>Totals</b>   | <b>359,312</b>             |   | <b>357,169</b>             |                                  |   |

<sup>a</sup> Vegetation classes (Receptor type) of the LOTOS-EUROS-Modelling of atmospheric N-deposition (Schaap et al. 2018).

<sup>b</sup> Utilised agricultural area (UAA) according to Agricultural Census, 2010.

<sup>c</sup> According to the 3rd National Forest Inventory (Thünen Institute, 2016c); cf. Section 8.1.1.

<sup>d</sup> Not including areas in the intertidal flats, for better comparability with the Destatis figures.

## 3.2 N<sub>2</sub>O and NO<sub>x</sub> emissions into the atmosphere

### 3.2.1 N<sub>2</sub>O and NO<sub>x</sub> emissions

Data for N<sub>2</sub>O and NO<sub>x</sub> emissions are provided in the tables of the German National Inventory Report (NIR; UBA 2016a) in the Common Reporting Format (CRF; download: [unfccc.int/national\\_reports/annex\\_i\\_ghg\\_inventories/national\\_inventories\\_submissions/items/9492.php](http://unfccc.int/national_reports/annex_i_ghg_inventories/national_inventories_submissions/items/9492.php); Status 14. Oct. 2016). The methodology and the data sources are outlined in the NIR report (UBA 2016a). For the presentation of the N-flows (Tab. 3-4), the CRF Tables 1 to 5 were evaluated; the CRF categories are mostly adopted for the N-flows. For better comparison, all the emissions in the CRF Tables 1 to 5 are included, even if they are below our threshold of 1 kt N a<sup>-1</sup>. For reasons of clarity, the N<sub>2</sub>O and NO<sub>x</sub> emissions from “Product Use” are allocated to “Materials and Products in Industry” pool rather than “Humans and Settlements” pool. No emissions are included in the CRF-Tables for the sub-pools “Food and Feed Processing” and “Other Land” or for the “Hydrosphere” pool.

Table 3-4: N<sub>2</sub>O and NO<sub>x</sub> emissions in Germany according to sectors, annual mean for 2010 - 2014 (Source: NIR, UBA 2016a, CRF-Tables 1 to 5; UNFCCC 2016).

| Flow code  | Sector of N <sub>2</sub> O and NO <sub>x</sub> emissions | CRF category                       | N <sub>2</sub> O<br>kt N a <sup>-1</sup> | NO <sub>x</sub><br>kt N a <sup>-1</sup> |
|--|--|------------------------------------|--|---|
| EF.EC-AT-gasEm   | Energy Conversion  | 1.A.1                              | 5.9                                      | 94.3                                    |
| EF.IC-AT-gasEm   | Manufacturing Industries and Construction                | 1.A.2                              | 1.7                                      | 29.4                                    |
| EF.TR-AT-gasEm   | Transport  | 1.A.3                              | 3.0                                      | 159.6                                   |
| EF.OE-AT-gasEm   | Other energy and fuels                                   | 1.A.4, 1.A.5,<br>1.B               | 1.1                                      | 44.0                                    |
| MP.NC-AT-gasEm   | Nitrogen chemistry                                       | 2.B                                | 2.0                                      | 8.7                                     |
| MP.OP-AT-gasEm   | Other producing industry                                 | 2.A, 2.C-2.H                       | 0.9                                      | 7.7                                     |
| HS.MW-AT-gasEm   | Material world (LULCC) <sup>b</sup>                      | 4.E, 4.H <sup>c</sup>              | 0.4                                      | n.r.                                    |
| AG.AH-AT-gasEm   | Animal husbandry (including manure management)           | 3.A,3.B                            | 8.3                                      | n.r.                                    |
| AG.SM-AT-gasEm   | Soil Management <sup>d</sup>                             | 3.D, 4.B, 4.C,<br>4.H <sup>e</sup> | 56.6                                     | 35.3                                    |
| AG.BG-AT-gasEm   | Biogas production  | 3.J                                | 0.6                                      | 0.7                                     |
| FS.FO-AT-gasEm   | Forest areas (LULCC)                                     | 4.A                                | 0.3                                      | n.r.                                    |
| FS.OL-AT-gasEm   | Wetlands (LULCC)   | 4.D                                | 0.0                                      | n.r.                                    |
| WS.SW-AT-gasEM   | Waste incineration plants and waste disposal sites       | 5.B, 5.C                           | 0.6                                      | 0.1                                     |
| WS.WW-AT-gasEM   | Wastewater treatment plants                              | 5.D, 5.E                           | 1.1                                      | n.r.                                    |
| <b>Total NO<sub>x</sub> and N<sub>2</sub>O emissions<sup>f</sup></b> |  |                                    | <b>82.6</b>                              | <b>379.9</b>                            |

n.r.: not relevant

<sup>a</sup> NO<sub>x</sub> calculated as NO<sub>2</sub>.<sup>b</sup> LULCC: Land Use and Land Cover Change; N<sub>2</sub>O emissions as a result of land use changes and humus depletion.<sup>c</sup> Position "Settlements".<sup>d</sup> Including LULCC for cropland and grassland.<sup>e</sup> Position "Grassland".<sup>f</sup> Not including NO<sub>x</sub> formation by lightning (see Section 3.2.2).

### 3.2.2 NO<sub>x</sub>-formation by lightning

According to the Siemens Lightning Information Service (BLIDS) there were an annual average of some 550,000 lightning flashes to ground in Germany 2013-2015 ([www.industry.siemens.com/services/global/de/portfolio/plant-data-services/blids/seiten/default.aspx](http://www.industry.siemens.com/services/global/de/portfolio/plant-data-services/blids/seiten/default.aspx)), corresponding to a mean flash density of 1.5 km<sup>-2</sup> a<sup>-1</sup>. With an emissions factor of NO<sub>x</sub>-formation of 0.7 kg NO<sub>x</sub> (from ground to 1 km altitude) per lightning flash according to Friedrich et al. (2018) or EEA (2016; Part B: Sectoral guidance chapters - 11.C Other natural sources) this results in some 117 t NO<sub>x</sub>-N a<sup>-1</sup> in Germany (Thomas Gauger, Institute of Navigation, INS, University of Stuttgart, written comm., 9.5.2018).

### 3.3 NH<sub>3</sub> emissions into the atmosphere

The data on ammonia emissions are taken from the CLRTAP Reports (national emissions reported to the Convention on Long-range Transboundary Air Pollution, LRTAP Convention, download [www.eea.europa.eu/data-and-maps/data/national-emissions-reported-to-the-convention-on-long-](http://www.eea.europa.eu/data-and-maps/data/national-emissions-reported-to-the-convention-on-long-)

range-transboundary-air-pollution-lrtap-convention-11)(Tab. 3-5). For the agricultural sector, the values were calculated for the National Emissions Inventory. However, the NIR only considers the NH<sub>3</sub> emissions as a precursor for the formation of greenhouse gases. In Rösemann et al. (2017), only Tab. 2.4 provides an overview of the total NH<sub>3</sub> emissions from agriculture (in all detailed tables concerning the NIR, ammonia emissions from housing and storage are not included).

Table 3-5: NH<sub>3</sub> emissions in Germany, annual mean for 2010 - 2014 (Sources: UNFCCC 2017; for Agriculture see also Rösemann et al. 2017, Tab. 2.4). Allocation of CRF-categories to sectors see Tab. 3-4.

| Flow code                             | Sector of NH <sub>3</sub> emissions   | N-species       | NH <sub>3</sub><br>kt N a <sup>-1</sup> |
|---------------------------------------|---|-----------------|---|
| EF.EC-AT-gasEm                        | NH <sub>3</sub> emissions from Energy Conversion  | NH <sub>3</sub> | 2.2                                     |
| EF.IC-AT-gasEm                        | NH <sub>3</sub> emissions from Manufacturing and Construction   | NH <sub>3</sub> | 0.8                                     |
| EF.TR-AT-gasEm                        | NH <sub>3</sub> emissions from Transport  | NH <sub>3</sub> | 11.5                                    |
| EF.OE-AT-gasEm                        | NH <sub>3</sub> emissions from Other Producing Industry   | NH <sub>3</sub> | 1.9                                     |
| MP.NC-AT-gasEm                        | NH <sub>3</sub> emissions from Nitrogen Chemistry   | NH <sub>3</sub> | 7.5                                     |
| MP.OP- AT-gasEm                       | NH <sub>3</sub> emissions from Other Producing Industry   | NH <sub>3</sub> | 4.3                                     |
| AG.AH-AT-gasEm                        | NH <sub>3</sub> emissions from housing and storage of animal excretions                               | NH <sub>3</sub> | 219.4                                   |
| AG.SM-AT-gasEm                        | NH <sub>3</sub> emissions from the application of organic and mineral fertilisers (including grazing) | NH <sub>3</sub> | 336.1                                   |
| AG.AH-AT-gasEm                        | NH <sub>3</sub> emissions from the storage of digestates  | NH <sub>3</sub> | 2.5                                     |
| WS.SW- AT-gasEm                       | Waste incineration plants and waste disposal sites  | NH <sub>3</sub> | 2.9                                     |
| WS.WW- AT-gasEm                       | Wastewater treatment plants   | NH <sub>3</sub> | 0.0                                     |
| <b>Total NH<sub>3</sub> emissions</b> |   |                 | <b>589.0</b>                            |

### 3.4 Atmospheric NH<sub>y</sub> and NO<sub>x</sub> depositions

The data on atmospheric deposition of nitrogen in reduced (NH<sub>y</sub>) and oxidised forms (NO<sub>x</sub>) in Germany are determined using the results of the UBA-Project PINETI-3 (Schaap et al. 2018). On the basis of emissions data, chemical transport models, interpolated data on wet depositions, and high-resolution land use data, the LOTOS-EUROS Model shows the annual total deposition of NH<sub>y</sub> (NH<sub>3</sub>, NH<sub>4</sub><sup>+</sup>) and NO<sub>x</sub> (HNO<sub>3</sub>, NO<sub>3</sub><sup>-</sup>, NO<sub>2</sub><sup>-</sup>, NO, N<sub>2</sub>O<sub>5</sub>) for various receptor surfaces (Schaap et al. 2018). The results are available as grid maps (1 km x 1 km) of the annual total depositions (wet, moist and dry) of NO<sub>3</sub>-N and NH<sub>4</sub>-N from 2000 to 2015 for ten receptor types. The receptor types were allocated to the corresponding land cover classes of the CLC 2012 map (see Tab. 3-2).

To determine the N-depositions in Germany, the PINETI-3 grid maps (1 km x 1 km) of annual N-depositions for the individual receptor types were superimposed in ArcGIS on the CLC2012 Land Cover map (10 ha minimum cartographic unit). Each grid cell was analysed for each receptor type, and on this basis weighted mean deposition rates of NH<sub>y</sub>, NO<sub>x</sub> and N<sub>r</sub>(total) were calculated for the vegetation classes in Germany (Tab. 3-6).

Table 3-6: Specific deposition rates of reactive nitrogen per hectare calculated on the basis of the real land use distribution (receptor types in PINETI-3 deposition modeling), annual mean for 2010 – 2014 (Schaap et al. 2018; our evaluation).

| Receptor type <sup>a</sup><br>(Land use category) | Short form | Deposition rate <sup>b</sup>                             |  |   |
|---|------------|--|--|---|
|   |            | NH <sub>y</sub><br>kg N ha <sup>-1</sup> a <sup>-1</sup> | NO <sub>x</sub><br>kg N ha <sup>-1</sup> a <sup>-1</sup> | N <sub>r</sub> total<br>kg N ha <sup>-1</sup> a <sup>-1</sup> |
| Arable land                                       | ara        | 9.3  | 4.4  | 13.7  |
| Grass land  | grs        | 8.7  | 4.4  | 13.1  |
| Permanent crops                                   | crp        | 7.0  | 5.7  | 12.8  |
| Semi-natural vegetation                           | sem        | 8.4  | 4.8  | 13.3  |
| Coniferous forest                                 | cnf        | 11.5   | 5.9  | 17.5  |
| Broad-leaved forest                               | dec        | 9.6  | 5.0  | 14.7  |
| Mixed forest                                      | mix        | 10.6   | 5.8  | 16.4  |
| Water bodies                                      | wat        | 7.7  | 3.6  | 11.3  |
| Urban fabric                                      | urb        | 12.1   | 5.9  | 18.0  |
| Other uses  | oth        | 6.6  | 4.9  | 11.5  |

<sup>a</sup> Vegetation classes (receptor type) of LOTOS-EUROS modelling of atmospheric N-depositions (Schaap et al. 2018).

<sup>b</sup> The deposition rates correspond largely to the values for real land use distribution in Table 10 of Schaap et al. (2018), with slight differences due to different reference periods.

Using the land cover areas (Tab. 3-2) and the receptor-specific N-deposition rates (Tab. 3-6), it is possible to calculate the atmospheric NO<sub>x</sub>- and NH<sub>y</sub>-depositions (Tab. 3-7).

Table 3-7: N-flows with atmospheric N-deposition, annual mean for 2010 – 2014.

| Flow code           | Description                                       | Area<br>ha | N-species       | N-deposition<br>kg N ha <sup>-1</sup> a <sup>-1</sup> | N-flow<br>kt N a <sup>-1</sup> |
|---------------------|---|------------|-----------------|---|--------------------------------|
| AT-AG.SM-<br>atmDep | Atmospheric N-deposition<br>on agricultural areas | 20,469,149 | NH <sub>y</sub> | 9.0   | 185.2                          |
|                     |   |            | NO <sub>x</sub> | 4.4   | 90.9                           |
|                     |   |            | N(tot)          | 13.5  | 276.1                          |
| AT-HS.MW-<br>atmDep | Atmospheric N-deposition<br>on urban fabric       | 3,376,347  | NH <sub>y</sub> | 11.8  | 40.0                           |
|                     |   |            | NO <sub>x</sub> | 5.8   | 19.5                           |
|                     |   |            | N(tot)          | 17.6  | 59.5                           |
| AT-FS.FO-<br>atmDep | Atmospheric N-deposition<br>on forest areas       | 11,077,730 | NH <sub>y</sub> | 10.7  | 118.9                          |
|                     |   |            | NO <sub>x</sub> | 5.6   | 62.2                           |
|                     |   |            | N(tot)          | 16.4  | 181.1                          |
| AT-FS.OL-<br>atmDep | Atmospheric N-deposition<br>on semi-natural areas | 656,472    | NH <sub>y</sub> | 8.0   | 5.3                            |
|                     |   |            | NO <sub>x</sub> | 4.1   | 2.7                            |
|                     |   |            | N(tot)          | 12.1  | 8.0                            |
| AT-FS.WL-<br>atmDep | Atmospheric N-deposition<br>on wetland            | 74,761     | NH <sub>y</sub> | 8.2   | 0.6                            |
|                     |   |            | NO <sub>x</sub> | 4.0   | 0.3                            |
|                     |   |            | N(tot)          | 12.2  | 0.9                            |
| AT-HY.SW-<br>atmDep | Atmospheric N-deposition<br>on surface waters     | 421,977    | NH <sub>y</sub> | 7.7   | 3.3                            |
|                     |   |            | NO <sub>x</sub> | 3.6   | 1.5                            |
|                     |   |            | N(tot)          | 11.3  | 4.8                            |
| AT-HY.CW-<br>atmDep | Atmospheric N-deposition<br>on coastal waters     | 162,461    | NH <sub>y</sub> | 7.7   | 1.3                            |
|                     |   |            | NO <sub>x</sub> | 3.6   | 0.6                            |
|                     |   |            | N(tot)          | 11.3  | 1.8                            |

| Flow code             | Description | Area<br>ha        | N-species             | N-deposition<br>kg N ha <sup>-1</sup> a <sup>-1</sup> | N-flow<br>kt N a <sup>-1</sup> |
|-----------------------|-------------|-------------------|-----------------------|---|--------------------------------|
| <b>Total, Germany</b> |             | <b>36,238,897</b> | <b>NH<sub>y</sub></b> | <b>9.8</b>  | <b>354.4</b>                   |
|                       |             |                   | <b>NO<sub>x</sub></b> | <b>4.9</b>  | <b>177.7</b>                   |
|                       |             |                   | <b>N(tot)</b>         | <b>14.7</b>   | <b>532.2</b>                   |

### 3.5 Imports and exports of NH<sub>y</sub> and NO<sub>x</sub>

As part of the European Monitoring and Evaluation Programme (EMEP 2017), the MSC-W (Meteorological Synthesizing Centre – West) calculates trans-boundary flows of NH<sub>y</sub> and NO<sub>x</sub> in Europe every year. The results provided in the EMEP Source-Receptor-Tables ([www.emep.int/mscw/mscw\\_srdata.html#SRtables](http://www.emep.int/mscw/mscw_srdata.html#SRtables)) were evaluated for Germany (Tab. 3-8).

Table 3-8: Import and export of reduced (NH<sub>y</sub>) and oxidised (NO<sub>x</sub>) atmospheric N-compounds according to EMEP Source-Receptor Tables, annual mean for 2010 – 2014.

| Import  |   |                               | Export                                  |   |                               |
|---|---|-------------------------------|---|---|-------------------------------|
| NH <sub>y</sub><br>kt N a <sup>-1</sup>                 | NO <sub>x</sub><br>kt N a <sup>-1</sup> | Total<br>kt N a <sup>-1</sup> | NH <sub>y</sub><br>kt N a <sup>-1</sup> | NO <sub>x</sub><br>kt N a <sup>-1</sup> | Total<br>kt N a <sup>-1</sup> |
| 103.7   | 114.7                                   | <b>218.4</b>                  | 248.8                                   | 280.5                                   | <b>529.3</b>                  |
| <b>Difference: Net export 310.9 kt N a<sup>-1</sup></b> |   |                               |   |   |                               |

The results of the Source-Receptor-Tables for the individual years are based in part on different model versions (cf. EMEP 2017, p. 135). Calculations using the EMEP approach give ~345 kt NH<sub>y</sub>-N a<sup>-1</sup> and ~184 kt NO<sub>x</sub>-N a<sup>-1</sup> deposition for Germany (annual mean for 2010 – 2014). This conforms well with the results from PINETI-3 deposition modeling (Schaap et al. 2018), namely 347 kt NH<sub>y</sub>-N and 178 kt NO<sub>x</sub>-N-deposition.

### 3.6 Summary of N-flows for the “Atmosphere” (AT) pool

The N-flows of the “Atmosphere” pool are summarised in Tab. 3-9.

Table 3-9: Incoming and outgoing N-flows in the “Atmosphere” pool, annual mean for 2010 – 2014.

| Pool(ex)                             | Pool(in) | Flow code               | Description  | N-species        | N-flow<br>kt N a <sup>-1</sup> |
|--------------------------------------|----------|-------------------------|--|------------------|--------------------------------|
| <b>Emissions into the Atmosphere</b> |          |                         |  |                  |                                |
| EF.EC                                | AT       | EF.EC-AT-gasEm          | NO <sub>x</sub> and N <sub>2</sub> O emissions from Energy Conversion                  | NO <sub>x</sub>  | 94.3                           |
|                                      |          |                         |  | N <sub>2</sub> O | 5.9                            |
| EF.EC                                | AT       | EF.EC-AT-gasEm          | NH <sub>3</sub> emission from Energy Conversion  | NH <sub>3</sub>  | 2.2                            |
| EF.EC                                | AT       | EF.EC-AT-N <sub>2</sub> | Oxidation/reduction of N <sub>r</sub> to N <sub>2</sub> during combustion and denoxing | N <sub>2</sub>   | 1417.6                         |
| EF.IC                                | AT       | EF.IC-AT-gasEm          | NO <sub>x</sub> and N <sub>2</sub> O emissions from Manufacturing and Construction     | NO <sub>x</sub>  | 29.4                           |
|                                      |          |                         |  | N <sub>2</sub> O | 1.7                            |
| EF.IC                                | AT       | EF.IC-AT-gasEm          | NH <sub>3</sub> emission from Manufacturing and Construction                           | NH <sub>3</sub>  | 0.8                            |
| EF.TR                                | AT       | EF.OE-AT-gasEm          | NO <sub>x</sub> and N <sub>2</sub> O emissions from Transport                          | NO <sub>x</sub>  | 159.6                          |
|                                      |          |                         |  | N <sub>2</sub> O | 3.0                            |
| EF.TR                                | AT       | EF.OE-AT-gasEm          | NH <sub>3</sub> emission from Transport  | NH <sub>3</sub>  | 11.5                           |



| Pool(ex) | Pool(in) | Flow code               | Description  | N-species                             | N-flow<br>kt N a <sup>-1</sup> |
|----------|----------|-------------------------|--|---------------------------------------|--------------------------------|
| EF.OE    | AT       | EF.OE-AT-gasEm          | NO <sub>x</sub> and N <sub>2</sub> O emissions from Other Energy and Fuels                             | NO <sub>x</sub><br>N <sub>2</sub> O   | 44.0<br>1.1                    |
| EF.OE    | AT       | EF.OE-AT-gasEm          | NH <sub>3</sub> emission from Other Energy and Fuels   | NH <sub>3</sub>                       | 1.9                            |
| MP.NC    | AT       | MP.NC-AT-gasEm          | NO <sub>x</sub> and N <sub>2</sub> O emissions from the chemical industry                              | NO <sub>x</sub><br>N <sub>2</sub> O   | 8.7<br>2.0                     |
| MP.NC    | AT       | MP.NC-AT-gasEm          | NH <sub>3</sub> emissions from the chemical industry   | NH <sub>3</sub>                       | 7.5                            |
| MP.OP    | AT       | MP.OP-AT-gasEm          | NO <sub>x</sub> and N <sub>2</sub> O emissions from Other producing industry                           | NO <sub>x</sub><br>N <sub>2</sub> O   | 7.7<br>0.9                     |
| MP.OP    | AT       | MP.OP-AT-gasEm          | NH <sub>3</sub> emission from Other producing industry   | NH <sub>3</sub>                       | 4.3                            |
| HS.MW    | AT       | HS.MW-AT-gasEm          | NO <sub>x</sub> and N <sub>2</sub> O emissions from settlement areas (LULCC) <sup>b</sup>              | NO <sub>x</sub><br>N <sub>2</sub> O   | n.r.<br>0.4                    |
| HS.HB    | AT       | HS.HB-AT-gasEm          | NH <sub>3</sub> emitted by humans  | NH <sub>3</sub>                       | 1.4                            |
| AG.AH    | AT       | AG.AH-AT-gasEm          | NO <sub>x</sub> and N <sub>2</sub> O emissions from Animal husbandry (including manure management)     | NO <sub>x</sub> ,<br>N <sub>2</sub> O | n.r.<br>8.3                    |
| AG.AH    | AT       | AG.AH-AT-gasEm          | NH <sub>3</sub> emissions from housing and storage of manure   | NH <sub>3</sub>                       | 219.4                          |
| AG.SM    | AT       | AG.SM-AT-gasEm          | NO <sub>x</sub> and N <sub>2</sub> O emissions from Soil Management                                    | NO <sub>x</sub><br>N <sub>2</sub> O   | 35.3<br>56.6                   |
| AG.SM    | AT       | AG.SM-AT-gasEm          | NH <sub>3</sub> emissions from the application of organic and mineral fertiliser                       | NH <sub>3</sub>                       | 336.1                          |
| AG.SM    | AT       | AG.SM-AT-N <sub>2</sub> | Denitrification on utilised agricultural areas (mineral soils and organic soils)                       | N <sub>2</sub>                        | 233.9                          |
| AG.BG    | AT       | AG.BG-AT-gasEm          | NO <sub>x</sub> and N <sub>2</sub> O emissions from biogas production                                  | NO <sub>x</sub><br>N <sub>2</sub> O   | 0.7<br>0.6                     |
| AG.BG    | AT       | AG.BG-AT-gasEm          | NH <sub>3</sub> emissions from biogas production   | NH <sub>3</sub>                       | 2.5                            |
| FS.FO    | AT       | FS.FO-AT-gasEm          | NO <sub>x</sub> and N <sub>2</sub> O emissions from forest areas (LULCC)                               | NO <sub>x</sub><br>N <sub>2</sub> O   | n.r.<br>0.3                    |
| FS.FO    | AT       | FS.FO-AT-N <sub>2</sub> | Denitrification in forest soils  | N <sub>2</sub>                        | 12.2                           |
| FS.OL    | AT       | FS.OL-AT-N <sub>2</sub> | Denitrification in semi-natural areas  | N <sub>2</sub>                        | 0.7                            |
| FS.WL    | AT       | FS.WL-AT-gasEm          | NO <sub>x</sub> and N <sub>2</sub> O emissions from Wetland (LULCC)                                    | NO <sub>x</sub><br>N <sub>2</sub> O   | n.r.<br>0.0                    |
| FS.WL    | AT       | FS.WL-AT-N <sub>2</sub> | Denitrification in Wetland   | N <sub>2</sub>                        | 1.5                            |
| WS.SW    | AT       | WS.SW-AT-gasEM          | NO <sub>x</sub> and N <sub>2</sub> O emissions from Waste incineration plants and waste disposal sites | NO <sub>x</sub><br>N <sub>2</sub> O   | 0.1<br>0.6                     |
| WS.SW    | AT       | WS.SW-AT-gasEM          | NH <sub>3</sub> emission from Waste incineration plants and waste disposal sites                       | NH <sub>3</sub>                       | 2.9                            |
| WS.WW    | AT       | WS.WW-AT-gasEM          | NO <sub>x</sub> and N <sub>2</sub> O emissions from Wastewater treatment plants                        | NO <sub>x</sub><br>N <sub>2</sub> O   | n.r.<br>1.1                    |
| WS.WW    | AT       | WS.WW-AT-N <sub>2</sub> | Denitrification in Wastewater treatment plants   | N <sub>2</sub>                        | 211.0                          |
| HY.GW    | AT       | HY.GW-AT-N <sub>2</sub> | Denitrification in the unsaturated zone and in groundwater   | N <sub>2</sub>                        | 572.0                          |

| Pool(ex)  | Pool(in) | Flow code       | Description  | N-species  | N-flow<br>kt N a <sup>-1</sup> |
|---|----------|-----------------|--|------------|--------------------------------|
| HY.SW   | AT       | HY.SW-AT-N2     | Denitrification (Retention) in surface waters      | N2         | 75.9                           |
| RW  | AT       | RW-AT-gasN      | Transboundary import of gaseous N-compounds        | NHy<br>NOx | 103.7<br>114.7                 |
| <b>N-depositions and N-fixing from the atmosphere</b> |          |                 |  |            |                                |
| AT  | HS.MW    | AT-HS.MW-atmDep | Atmospheric N-deposition on urban areas            | NHy<br>NOx | 40.0<br>19.5                   |
| AT  | AG.SM    | AT-AG.SM-atmDep | Atmospheric N-deposition on agricultural areas     | NHy<br>NOx | 185.2<br>90.9                  |
| AT  | AG.SM    | AT-AG.SM-Nfix   | Biological N-fixing in utilised agricultural areas | N(org)     | 194.6                          |
| AT  | FS.FO    | AT-FS.FO-atmDep | Atmospheric N-deposition on forest areas           | NHy<br>NOx | 118.9<br>62.2                  |
| AT  | FS.FO    | AT-FS.FO-Nfix   | Biological nitrogen fixing in forest soil          | N(org)     | 110.5                          |
| AT  | FS.OL    | AT-FS.OL-atmDep | Atmospheric N-deposition on seminatural areas      | NHy<br>NOx | 5.3<br>2.7                     |
| AT  | FS.OL    | AT-FS.OL-Nfix   | Biological nitrogen fixing in semi-natural areas   | N(org)     | 15.8                           |
| AT  | FS.WL    | AT-FS.WL-atmDep | Atmospheric N-deposition on wetland                | NHy<br>NOx | 0.6<br>0.3                     |
| AT  | FS.WL    | AT-FS.WL-Nfix   | Biological nitrogen fixing in wetland              | N(org)     | 0.7                            |
| AT  | HY.SW    | AT-HY.SW-atmDep | Atmospheric N-deposition on surface waters         | NHy<br>NOx | 3.3<br>1.5                     |
| AT  | HY.CW    | AT-HY.CW-atmDep | Atmospheric N-deposition on coastal waters         | NHy<br>NOx | 1.3<br>0.6                     |
| AT  | RW       | AT-RW-gasN      | Transboundary export of gaseous N-compounds        | NHy<br>NOx | 248.8<br>280.5                 |

n.r.: not relevant.

LULCC: Land Use and Land Cover Change; N<sub>2</sub>O emissions as a result of land cover changes and humus depletion.

### 3.7 Balance and comments for the “Atmosphere” (AT) pool

The balance of gaseous reactive N-compounds in the atmosphere above Germany includes domestic emissions and imports, against depositions and exports (Tab. 3-10).

There is a difference of 210 kt N a<sup>-1</sup> between total inflows and outflows. This could be due to different assumptions made when modelling atmospheric NO<sub>x</sub> and NH<sub>y</sub> flows with LOTOS-EUROS (PINETI-3, Schaap et al. 2018) and EMEP (EMEP 2017). Excluding N<sub>2</sub>O, which is not deposited and for which neither model includes imports or exports, then the difference between total inflow and total outflow is reduced to 126 kt N a<sup>-1</sup>, or some 10 %. An uncertainty of this order is typical for the comparison of two large-scale models. Furthermore, a value of 10 % is also within the range of the data quality targets for the assessment of air quality using the modelling.

In summary, about 60 % of national NH<sub>3</sub> emissions and 45 % of national NO<sub>x</sub> emissions are redeposited in Germany. Overall, Germany is therefore an exporter of air pollutants. A simplified explanation for this is that Germany has a high density of emissions, with emission hotspots in the north-west and south-east, and a large proportion of the emissions are transported in the atmosphere over long

distances (among other things due to particle formation), and carried over national borders by prevailing south-west winds.

Table 3-10: Balance of reactive N-flows in the “Atmosphere” pool for Germany (without denitrification), annual mean for 2010 – 2014.

| N-flows                     | NO <sub>x</sub><br>kt N a <sup>-1</sup> | N <sub>2</sub> O<br>kt N a <sup>-1</sup> | NH <sub>y</sub><br>kt N a <sup>-1</sup> | Total<br>kt N a <sup>-1</sup> |
|-----------------------------|---|--|---|-------------------------------|
| <b>Emissions in Germany</b> | <b>380</b>                              | <b>83</b>                                | <b>590</b>                              | <b>1053</b>                   |
| Imports                     | 115                                     | n.r.                                     | 104                                     | 218                           |
| <b>Total Inflow</b>         | <b>495</b>                              | <b>83</b>                                | <b>694</b>                              | <b>1271</b>                   |
| <b>Depositions</b>          | - 178                                   | 0  | - 354                                   | - 532                         |
| Exports                     | - 281                                   | n.r.                                     | - 249                                   | - 530                         |
| <b>Total Outflow</b>        | <b>- 458</b>                            | <b>0</b>                                 | <b>- 603</b>                            | <b>- 1062</b>                 |

n.r.: not relevant.

The EMEP emissions factors for the release of NH<sub>3</sub> from mineral fertiliser were changed four times between 2003 and 2013, in line with advances in scientific knowledge (cf. Osterburg 2015). There is a difference of some 57 kt NH<sub>3</sub>-N a<sup>-1</sup> between the lowest value of ~58 kt NH<sub>3</sub>-N a<sup>-1</sup>, calculated with the EMEP emission factors for 2009, and the highest value of ~115 kt NH<sub>3</sub>-N a<sup>-1</sup> calculated with the EMEP emission factors for 2013 (annual mean for 2009 - 2012). This difference highlights the extent to which the results for emissions depend on the modelling assumptions that are made. The NH<sub>3</sub> emissions factors may be changed again in future, and when applied retrospectively would lead to another change in the results for the NH<sub>3</sub> flow.

Similar conclusions apply for NH<sub>y</sub> and NO<sub>x</sub> depositions. Extensive model results were first provided by Gauger et al. (2008) for the period 1995 to 2004. In the MAPESI Project (Bultjes et al. 2011), deposition values were modeled for 2005 to 2007, but without comparisons to the previous approach. The results of the follow-up project, PINETI-2, were some 27 % lower than the MAPESI results (for the entire acidifying depositions from the atmosphere), which the authors attributed to the improved methodology for determining the wet depositions and the consolidation of new process descriptions in the LOTOS-EUROS Model (Schaap et al. 2017). The latest version (PINETI-3, Schaap et al. 2018) models the depositions for the period 2000 to 2015, allowing a comparison with the results of Gauger et al. (2008). As annual means for the period 2000 to 2004, PINETI-3 calculates 9.3 kg NH<sub>y</sub>-N ha<sup>-1</sup> a<sup>-1</sup> and 6.2 kg NO<sub>x</sub>-N ha<sup>-1</sup> a<sup>-1</sup> deposition on the agricultural area, whereas according to Gauger et al. (2008) the depositions in this period were 15.2 kg NH<sub>y</sub>-N ha<sup>-1</sup> a<sup>-1</sup> and 8.9 kg NO<sub>x</sub>-N ha<sup>-1</sup> a<sup>-1</sup>.

### 3.8 Uncertainty assessment for the N-flows of “Atmosphere” (AT) pool

Tab. 3-11 shows the uncertainties in the calculation of the N-flows for the “Atmosphere” pool.

Table 3-11: Uncertainties in the calculation of N-flows for the “Atmosphere” pool.

| Flow code                        | Description   | N-species                            | Uncertainty (quantity structure and coefficients)  | Level <sup>a</sup> |
|----------------------------------|---|--------------------------------------|--|--------------------|
| XX.XX-AT-gasEm                   | N <sub>2</sub> O and NO <sub>x</sub> emissions - total (Tab. 3-4) | N <sub>2</sub> O<br>NO <sub>x</sub>  | The uncertainties of the activity data and the emissions factors are described in the NIR for each category (UBA, 2016a). The <u>overall uncertainty</u> for the N <sub>2</sub> O and NO <sub>x</sub> emissions <u>combined</u> relates mainly to the emissions from agricultural soils (3.D) and from municipal wastewater treatment (5 D.1); the uncertainties of NO <sub>x</sub> emissions is given as 27% (as 95%-uncertainty).              | 2                  |
| AG.XX-AT-gasEM<br>AG.SM-AT-gasEm | N <sub>2</sub> O emissions Agriculture                            | N <sub>2</sub> O                     | For the <u>agricultural part</u> of the NIR, Rösemann et al. (2017; Tab. 14.1) estimate the overall uncertainty (as a combination of the uncertainty of the activity data and the uncertainty of the emissions factors) for <u>N<sub>2</sub>O emissions</u> from animal husbandry at more than 100 % (defined as “range of the half length of the 95 % confidence interval”) and for N <sub>2</sub> O emissions from soils at more than 300 %.   | 4                  |
| AG.XX-AT-gasEM<br>AG.SM-AT-gasEm | NH <sub>3</sub> emissions Agriculture                             | NH <sub>3</sub>                      | For the <u>agricultural part</u> of the NIR, Rösemann et al. (2017; Tab. 14.2) estimate the overall uncertainty (as a combination of the uncertainty of the activity data and the uncertainty of the emissions factors) for the <u>NH<sub>3</sub> emissions</u> from animal husbandry at about 37 % (defined as “range of the half length of the 95 % confidence interval”) and for NH <sub>3</sub> emission from mineral fertilisation at 50 %. | 3                  |
| AT-XX.XX-atmDep                  | Atmospheric NH <sub>y</sub> and NO <sub>x</sub> deposition        | NH <sub>y</sub> ,<br>NO <sub>x</sub> | On the uncertainties of modelling <u>NH<sub>y</sub> and NO<sub>x</sub> deposition</u> see PINETI-3 project report (Schaap et al. 2018).  | 3                  |

<sup>a</sup>) Level of uncertainty in accordance with Tab. 2-3.

## 4 Energy and Fuels (EF)

The “Energy and Fuels” pool covers N-flows related to energy conversion and the extraction and combustion of fuels (e.g. conversion of crude oil or energy crops). The N-flows originate above all from the formation of NO<sub>x</sub> and N<sub>2</sub>O from N<sub>2</sub> and O<sub>2</sub> at high temperatures. Tab. 4-1 gives an overview of the relevant nitrogen flows for four sub-pools:

- ▶ Energy Conversion (EF.EC)
- ▶ Manufacturing Industries and construction (EF.IC)
- ▶ Transport (EF.TR)
- ▶ Other Energy and fuels (EF.OE).

Table 4-1: Incoming and outgoing N-flows of sub-pools of the “Energy and Fuels” pool.

| Pool(ex)  | Pool(in)               | Flow code          | Description   | N-species  | Section |
|---|------------------------|--------------------|---|--|---------|
| <b>Sub-Pool “Energy Conversion” (EF.EC)</b>                         |                        |                    |   |  |         |
| SOURCE <sup>a</sup>   | EC.EF                  | SOURCE-EC.EF-fuel  | Domestic extraction of fossil fuels   | N(org)   | 4.1.1   |
| SOURCE <sup>a</sup>   | EC.EF                  | SOURCE-EC.EF-gasEM | Formation of thermal NO <sub>x</sub>  | NO <sub>x</sub>                                      | 4.1.2   |
| MP.FP   | EF.EC                  | MP.FP-EF.EC-fuel   | Agricultural products to produce fuels  | N(org)   | 4.1.3   |
| MP.NC   | EF.EC                  | MP.NC-EF.EC-prod   | NH <sub>3</sub> for denoxing of flue gases  | NH <sub>3</sub>                                      | 4.1.3   |
| FS.FO   | EF.EC                  | FS.FO-EF.EC-wood   | Wood for energetic use - large combustion plants  | N(org)   | 8.1.5   |
| RW  | EF.EC                  | RW-EF.EC-fuel      | Import of fossil fuels and mineral-oil products   | N(org)   | 4.1.1   |
| EF.EC   | SINK <sup>a</sup> (AT) | EF.EC-AT-N2        | Oxidation/reduction of N <sub>r</sub> to N <sub>2</sub> during combustion and denoxing        | N <sub>2</sub>                                       | 4.1.5   |
| EF.EC   | SINK <sup>a</sup> (AT) | EF.EC-SINK-N2      | N <sub>r</sub> loss during refining of crude oil  | N <sub>2</sub>                                       | 4.1.1   |
| EF.EC   | AT                     | EF.EC-AT-gasEm     | NO <sub>x</sub> and N <sub>2</sub> O emissions from combustion processes in Energy conversion | NH <sub>y</sub> , NO <sub>x</sub> , N <sub>2</sub> O | 3.2.1   |
| EF.EC   | EF.IC                  | EF.EC-EF.IC-fuel   | Fossil fuels for industrial uses  | N(org)   | 4.1.1   |
| EF.EC   | EF.TR                  | EF.EC-EF.TR-fuel   | Fossil fuels for use in Transport   | N(org)   | 4.1.1   |
| EF.EC   | EF.TR                  | EF.EC-EF.TR-fuel   | Fossil fuels for use in households, trade and commerce  | N(org)   | 4.1.1   |
| EF.EC   | MP.FP                  | EF.EC-MP.FP-prod   | Residues from the production of fuels from agricultural products                              | N(org)   | 4.1.3   |
| EF.EC   | MP.NC                  | EF.EC-MP.NC-prod   | Crude oil and mineral-oil products as resources for the chemical industry                     | N(org)   | 4.1.1   |
| EF.EC   | WS.SW                  | EF.EC-WS.SW-waste  | Waste from the production of fuels and refinery products                                      | N(org)   | 9.1.1   |
| EF.EC   | WS.WW                  | EF.EC-WS.WW-sewage | Wastewater from Energy Conversion   | N(org)   | 9.2.1   |
| EF.EC   | RW                     | EF.EC-RW-fuel      | Export of fossil fuels and refinery products  | N(org)   | 4.1.1   |
| <b>Sub-Pool “Manufacturing Industries and Construction” (EF.IC)</b> |                        |                    |   |  |         |
| EF.EC   | EF.IC                  | EF.EC-EF.IC-fuel   | Fossil fuels for industrial uses  | N(org)   | 4.1.1   |
| EF.IC   | AT                     | EF.IC-AT-gasEm     | NO <sub>x</sub> and N <sub>2</sub> O emissions from industrial combustion processes           | NH <sub>y</sub> , NO <sub>x</sub> , N <sub>2</sub> O | 3.2.1   |

| Pool(ex)   | Pool(in) | Flow code          | Description   | N-species  | Section |
|--|----------|--------------------|---|--|---------|
| <b>Sub-Pool “Transport” (EF.TR)</b>              |          |                    |   |  |         |
| EF.EC  | EF.TR    | EF.EC-EF.TR-fuel   | Fossil fuels for use in Transport   | N(org)   | 4.1.1   |
| SOURCE <sup>a</sup>                              | EC.EF    | SOURCE-EC.EF-gasEM | Formation of thermal NO <sub>x</sub>  | NO <sub>x</sub>                                      | 4.1.2   |
| EF.TR  | AT       | EF.TR-AT-gasEm     | NO <sub>x</sub> and N <sub>2</sub> O emissions from combustion processes in Transport         | NH <sub>y</sub> , NO <sub>x</sub> , N <sub>2</sub> O | 3.2.1   |
| <b>Sub-Pool “Other energy and fuels” (EF.OE)</b> |          |                    |   |  |         |
| EF.EC  | EF.OE    | EF.EC-EF.OE-fuel   | Fossil fuels for use in households, trade and commerce  | N(org)   | 4.1.1   |
| SOURCE <sup>a</sup>                              | EC.EF    | SOURCE-EC.EF-gasEM | Formation of thermal NO <sub>x</sub>  | NO <sub>x</sub>                                      | 4.1.2   |
| FS.FO  | EF.OE    | FS.FO-EF.OE-wood   | Wood for energetic use - private households   | N(org)   | 8.1.5   |
| EF.OE  | AT       | EF.OE-AT-gasEm     | NO <sub>x</sub> and N <sub>2</sub> O emissions from combustion processes in Energy conversion | NH <sub>y</sub> , NO <sub>x</sub> , N <sub>2</sub> O | 3.2.1   |

<sup>a</sup> On Pool(ex) SOURCE and Pool(in) SINK see Section 4.4; allocated to Pool(in) AT in the STAN-Diagram (Chapter 12).

No separate statistics are available for waste and wastewater from the energy sector. Waste materials from the energy industry are not included as N-flow. Waste and wastewater in this sector are covered in the N-flows for the “Material and Products in Industry” pool.

## 4.1 Sub-pool “Energy Conversion” (EF.EC)

The sub-pool “Energy Conversion” brings together N-flows from the generation of electrical power and heat by the combustion of fossil fuels, including the extraction, production or refining of the fuel. It also includes the production of bioethanol and biodiesel. Power generation in waste incineration plants is considered as belonging to the “Waste” pool, and biogas plants as allocated to the “Agriculture” pool.

### 4.1.1 Origin and use of fossil fuels (XX-EF.EC-fuel, EF.EC-XX-fuel)

The Energy Balance of the Federal Republic of Germany collates the amounts of fuel used for various purposes. Tab. 4-2 presents a summary of the Energy Balance (AGEB 2017) with the derived N-flows. In a first step, the entire domestic production of fossil fuels containing nitrogen is divided between energetic and non-energetic uses, and then the energetic uses are assigned to the four sub-pools of “Energy and Fuels” pool.

Table 4-2: Energy Balance for Germany (except for fossil fuels containing nitrogen) – summarised results with allocation to N-flows, annual mean for 2010 - 2014 (source: AGEB 2017; adapted).

| Flow code   | Position in the energy balance  | Natural amounts             |                                |                           |                           | N-flow                                    |  |                                   |                                     | TOTAL<br>kt N a <sup>-1</sup> |
|---|---|-----------------------------|--------------------------------|---------------------------|---------------------------|---|--|-----------------------------------|-------------------------------------|-------------------------------|
|   |   | Coal <sup>a</sup><br>1000 t | Lignite <sup>b</sup><br>1000 t | Crude oil<br>1000 t       | Mineral oil<br>1000 t     | Coal <sup>a</sup><br>kt N a <sup>-1</sup> | Lignite <sup>b</sup><br>kt N a <sup>-1</sup> | Crude oil<br>kt N a <sup>-1</sup> | Mineral oil<br>kt N a <sup>-1</sup> |                               |
|   | <b>N-content in kg N t<sup>-1</sup> <sup>c</sup></b>                                | <b>14.0</b>                 | <b>3.0</b>                     | <b>10.0</b>               | <b>1.26<sup>d</sup></b>   |   |  |                                   |                                     |                               |
| SOURCE-EF.EC-fuel                                       | Domestic production   | 9,509                       | 180,771                        | 2577                      | 0                         | 133.1                                     | 542.3  | 22.2                              | 0.0                                 | 694.4                         |
| RW-EC.EC-fuel   | Imports of fuels and mineral oil products   | 55,836                      | 81                             | 90,977                    | 34,916                    | 781.7                                     | 0.2  | 909.8                             | 43.3                                | 1735.0                        |
| EF.EC-RW-fuel   | Exports of fuels and mineral oil products, including international marine bunkering | 1,026                       | 1,844                          | 158                       | 22,073                    | 14.4                                      | 5.5  | 1.7                               | 41.1                                | 62.7                          |
| <b>Primary domestic energy consumption <sup>e</sup></b> |   | <b>63,840</b>               | <b>178,332</b>                 | <b>93,028</b>             | <b>13,291</b>             | <b>897.4</b>                              | <b>536.8</b>                                 | <b>930.3</b>                      | <b>2.2</b>                          | <b>2366.7</b>                 |
| (EF.EC intern)  | Energy sector (direct) <sup>f</sup>   | 52,203                      | 173,767                        | 0                         | 7,546                     | 734.5 <sup>f</sup>                        | 523.1 <sup>f</sup>                           | 930.3 <sup>f</sup>                | 70.0 <sup>f</sup>                   | 2117.9 <sup>f</sup>           |
| EF.EC-EF.IC-fuel  | Mining, metallurgy, manufacturing, other segments, etc.                             | 10,893                      | 3601                           | 0                         | 2,329                     | 152.5                                     | 10.8   |                                   | 4.5                                 | 167.8                         |
| EF.EC-EF.TR-fuel  | Transport, total  | 0                           | 0                              | 0                         | 56,052                    |   |  |                                   | 31.7                                | 31.7                          |
| EF.EC-EF.OE-fuel  | Households, commerce, trade   | 744                         | 964                            | 0                         | 19,488                    | 10.4                                      | 2.9  |                                   | 3.9                                 | 17.2                          |
| <b>Total energetic consumption <sup>g</sup></b>         |   | <b>63,840</b>               | <b>178,332</b>                 | <b>0</b>                  | <b>85,415</b>             | <b>897.4</b>                              | <b>536.8</b>                                 | <b>0</b>                          | <b>29.9</b>                         | <b>2334.6<sup>g</sup></b>     |
| EF.EC-MP.NC-prod  | Mineral oil products as inputs for the chemicals industry                           | 0                           | 0                              | 0                         | 20,298                    |   |  |                                   | 32.1                                | 32.1                          |
| <b>Non-energetic consumption, total</b>                 |   | <b>0</b>                    | <b>0</b>                       | <b>93,028<sup>h</sup></b> | <b>20,298<sup>h</sup></b> | <b>0</b>                                  | <b>0</b>                                     | <b>(930.3)<sup>h</sup></b>        | <b>32.1<sup>h</sup></b>             | <b>32.1</b>                   |

<sup>a</sup> Coal, briquettes, coke and other coal products.

<sup>b</sup> Briquettes and other lignite products.

<sup>c</sup> N-contents after GEMIS 2 (Fritsche et al., 1994).

<sup>d</sup> Mean for all products; value is only for the total domestic primary energy consumption.

<sup>e</sup> More accurately: Primary fuel consumption: Figures include changes in stocks (not shown separately).

<sup>f</sup> As the difference between "Overall energetic use" and the total(EF.EC-EF.IC-fuel, EF.EC-EF.TR-fuel, EF.EC-EF.OE-fuel); see Section 4.6.

<sup>g</sup> In contrast to AGEB (2017), values are calculated as the difference between primary domestic energy consumption and non-energetic consumption (including stat. differences).

<sup>h</sup> For the N-balance between crude oil inputs and refined outputs as mineral-oil products see Tab. 4-3.

It should be noted that the Energy Balance is structured primarily to register the conversion and uses of energy. The material flows for fuel include double counting and uncertainties for various positions, as is pointed out in the comments (AGEB 2015). However, double counting in the statistics cannot be corrected by an external user. The effects were unfortunately carried over to the nitrogen flows when we calculated these from the Energy Balance on the basis of this incomplete information (Tab. 4-2).

The Energy Balance also includes fuel conversion inputs and outputs. This relates in particular to the refining of crude oil to mineral oil products (in ten product groups). However, there is a considerable gap here in the N-flows. In the period 2010 – 2014, Germany imported some 93 million tonnes of crude oil every year (as well as ~13.3 million t mineral-oil products). Assuming a nitrogen content of 1 % in crude oil (after GEMIS, Fritsche et al. 1994) this corresponds to a total of ~932 kt N a<sup>-1</sup>. Crude oil is almost completely refined to mineral-oil products (e.g. by distillation and conversion). But the N-contents of most conversion products is well below 1 % N (after GEMIS, Fritsche et al. 1994), so that the total N-flow for all mineral-oil products after refining of the crude oil total is only 114 kt N a<sup>-1</sup> (Tab. 4-3).

Table 4-3: N-flows with imports of crude oil and mineral-oil products as well as from refinery products, annual mean for 2010 – 2014 (based on: AGEB 2017).

| Product                    | N-content <sup>a</sup><br>kg N t <sup>-1</sup> | Import              |                                | Use after conversion |                                |
|----------------------------|--|---------------------|--------------------------------|----------------------|--------------------------------|
|                            |  | Product<br>1000 t   | N-flow<br>kt N a <sup>-1</sup> | Product<br>1000 t    | N-flow<br>kt N a <sup>-1</sup> |
| Crude oil                  | 10.0   | 93,028              | 930.3                          |                      |                                |
| Mineral-oil products:      |  |                     |                                |                      |                                |
| Petrol                     | 1.0  | -2,986 <sup>b</sup> | -3.0                           | 21,947               | 21.9                           |
| Naphtha                    | 1.0  | 6,160               | 6.2                            | 10,216               | 10.2                           |
| Kerosene type jet fuel     | 1.0  | 3,648               | 3.6                            | 4,902                | 4.9                            |
| Diesel fuel                | 0.2  | 4,660               | 0.9                            | 27,299               | 5.5                            |
| Light heating oil          | 0.2  | 3,905               | 0.8                            | 15,499               | 3.1                            |
| Heavy heating oil          | 4.5  | -2,124 <sup>b</sup> | -9.6                           | 8,519                | 38.3                           |
| Petroleum coke             | 15.5   | 235                 | 3.6                            | 1,774                | 27.5                           |
| Liquid gas                 | 0  | 642                 | 0.0                            | 2,646                | 0                              |
| Refinery gas               | 0  | 46                  | 0.0                            | 4,092                | 0                              |
| Other mineral-oil products | 0.3  | -895 <sup>b</sup>   | -0.3                           | 8,819                | 2.6                            |
| <b>Total</b>               | (1.26) <sup>c</sup>                            | <b>106,319</b>      | <b>932.5</b>                   | <b>105,713</b>       | <b>114.0</b>                   |

<sup>a</sup> N-contents according to GEMIS 2 (Fritsche et al., 1994).

<sup>b</sup> Net exports.

<sup>c</sup> N-content as a mean for all mineral-oil products.

Within the framework of this study it was not possible to determine whether the considerable difference of 818 kt N a<sup>-1</sup> represents a statistical artefact, for example as a result of inaccurate standard values for the N-contents of the products in question, or whether there is indeed such an oxidation/reduction of N<sub>r</sub> to N<sub>2</sub> in oil refineries. The term “N<sub>r</sub> loss” is used to refer to the difference. The Association of the German Petroleum Industry (MWV) responded to our enquiry as follows: “Organic and inorganic compounds in crude oil contain nitrogen. In a first refining step, desalting washes out inorganic N-compounds. In some processing and enrichment steps following the crude oil distillation,



ammonia is produced from organic N-compounds (e.g. in the hydrofiner: de-sulphurisation by catalytic hydration reactions). Gaseous  $\text{NH}_3$  is converted to  $\text{N}_2$ , e.g. in Claus units by partial oxidation and comproportionation, and this is emitted. The nitrogen compounds dissolved in the industrial process water of the crude oil refining and further processes are denitrified in the wastewater treatment plant” (MWV, written communication, 3 May 2018).

There are only small levels of direct nitrogen discharges from refineries. The Pollutant Release and Transfer Register (PRTR; UBA 2016b) lists under “Mineral oil and gas refineries” for three refineries (or operators) a total of  $163 \text{ t N}(\text{tot}) \text{ a}^{-1}$  (annual mean for 2010-2014). The PRTR register only includes two refineries as ammonia emitters, with combined emissions of  $61 \text{ t NH}_3\text{-N a}^{-1}$ . For the further considerations, we therefore assume that the (statistical) N-loss of  $818 \text{ kt N a}^{-1}$  is all released as  $\text{N}_2$ .

#### 4.1.2 Formation of thermal $\text{NO}_x$

Nitrogen oxides (mainly  $\text{NO}$  and  $\text{NO}_2$ ) are formed by combustion processes involving either molecular  $\text{N}_2$  in the air (thermal  $\text{NO}_x$ ) or reactive nitrogen contained in the fuel (fuel  $\text{NO}_x$ ). For the nitrogen budget it is therefore necessary to determine how much  $\text{NO}_x$  is newly formed by combustion processes, and how much  $\text{NO}_x$  is formed by the transformation of nitrogen compounds already present in the fuel, without an increase in the quantity of  $\text{N}_r$ . In Tab. 4-4, the total  $\text{NO}_x$  emissions are presented, with the estimated new formation of  $\text{N}_r$  in the form of thermal  $\text{NO}_x$ .

Table 4-4: Proportion of thermal  $\text{NO}_x$  emissions in total  $\text{NO}_x$  formed by combustion.

| Source sector   | $\text{NO}_x$ emissions <sup>a</sup> |                      | Of which thermal $\text{NO}_x$ |                      |
|---|--------------------------------------|----------------------|--------------------------------|----------------------|
|   | Fuel                                 | kt N a <sup>-1</sup> | % <sup>b</sup>                 | kt N a <sup>-1</sup> |
| Energy sector and Manufacturing Industries and Construction | together                             | 123.7                |                                | 30.0                 |
| - of which generation by                                    | - Coal                               | 40.8 <sup>c</sup>    | 20 %                           | 8.2                  |
|   | - Lignite                            | 64.3 <sup>c</sup>    | 5 %                            | 3.2                  |
|   | - Gas                                | 18.6 <sup>c</sup>    | 100 %                          | 18.6                 |
| Transport   | Diesel/petroleum                     | 159.6                | 100 % <sup>d</sup>             | 159.6                |
| Other energy and fuels                                      | (various)                            | 44.0                 | 5 % <sup>e</sup>               | 2.2                  |
| Other sources   | (various)                            | 52.6                 | 0 %                            | 0.0                  |
| <b>Total <math>\text{NO}_x</math> emissions</b>             |                                      | <b>379.9</b>         | <b>(50 %)<sup>f</sup></b>      | <b>191.8</b>         |

<sup>a</sup> See Tab. 3-4.

<sup>b</sup> Estimated proportion of thermal  $\text{NO}_x$  in total  $\text{NO}_x$  emissions.

<sup>c</sup> Calculated from the data in TJ (power, heat, industrial uses) according to Energy Balance (AGEB 2017) and fuel and process related  $\text{NO}_x$  emission factors for power generation (Fritsche and Rausch 2007).

<sup>d</sup> Estimated - UBA (written communication 2018).

<sup>e</sup> Estimated value (placeholder).

<sup>f</sup> Proportion of thermal  $\text{NO}_x$  in total  $\text{NO}_x$  emissions.

Taking all sources of  $\text{NO}_x$  emissions, including those outside the energy sector, the  $\text{NO}_x$  emissions consist in almost equal parts of thermal  $\text{NO}_x$  ( $\sim 192 \text{ kt N a}^{-1}$ ) and non-thermal  $\text{NO}_x$  ( $\sim 188 \text{ kt N a}^{-1}$ ).

### 4.1.3 Producing fuel from biomass (MP.FP-EF.EC-fuel)

In Germany, an annual mean of some 2.76 million t of biodiesel and some 620,000 t of bioethanol were produced from agricultural materials in the period 2010-2014. Nitrogen contained in the initial crop retained more or less completely in the production residues, so that the fuels are almost N-free.

Biodiesel and plant oil fuels are produced almost exclusively from rape-seed, and it can be assumed that the press cake is used for animal feed. Bioethanol is produced from a wider range of crops. When grain crops are used, this can also produce foodstuffs and animal feed containing protein (e.g. bran, gluten, and spent grain). According to the *Bundesverband der Deutschen Bioethanolwirtschaft (BDBE)*, spent grain can be used either on its own in a dried and pelleted form or as a wet product, or it can be used as a component in mixed feed. Some spent grain is also used for biogas production. When producing bioethanol from sugar beet, associated products include in particular sugar beet pulp and pellets, vinasse, and ammonium sulphate. Sugar beet pulp, press cakes and vinasse are used in the feed industry, and in part also for biogas generation, while ammonium sulphate is used as fertiliser. However, no statistics are available about the distribution of residues from bioethanol production. According to the estimates of BDBE, a large proportion of the side-products are used as mixed-feed components (BDBE, written communication, 29.3.2018). Tab. 4-5 summarises the N-flows for the energy crops used to produce fuels.

Table 4-5: Areas, yields and N-flows for energy crops used to produce fuels (FNR 2018), annual mean 2012 - 2014.

| Crop                                | Area<br>ha     | Yield<br>dt ha <sup>-1</sup> | N-contents<br>% | N-flow<br>kt N a <sup>-1</sup> |
|-------------------------------------|----------------|------------------------------|-----------------|--------------------------------|
| Rape-seed for biodiesel / plant oil | 733,000        | 40.4                         | 3.35            | 99.3                           |
| Crops for bioethanol:               |                |                              |                 |                                |
| - Sugar beet                        | 37,267         | 708.7                        | 0.18            | 4.8                            |
| - Wheat                             | 58,067         | 80.4                         | 1.80            | 8.4                            |
| - Rye                               | 39,833         | 58.6                         | 1.56            | 3.6                            |
| - Maize                             | 21,900         | 100.8                        | 1.72            | 3.8                            |
| - Other feed grain (mainly barley)  | 30,100         | 70.5                         | 1.80            | 3.8                            |
| Total - Bioethanol                  | 187,167        |                              |                 | 24.4                           |
| <b>Total Energy crops for fuels</b> | <b>920,167</b> |                              |                 | <b>123.7</b>                   |

For our purposes, it is assumed as a simplification that all the residues from the production of the fuels from agricultural biomass are passed on to the feed industry. Further, it is assumed that all the nitrogen from the agricultural biomass is retained in the residues, i.e. the fuels themselves are completely N-free and there are no relevant N-losses. The N-inflow for the production of fuels from biomass therefore corresponds to the N-outflow.

### 4.1.4 Ammonia consumption for flue gas denoxing (MP.NC-EF.EC-prod)

In order to comply with NO<sub>x</sub> limit values in the flue gases from power stations, nitrogen oxide is reduced to water and dinitrogen (N<sub>2</sub>) by the addition of ammonia. This is referred to as denoxing of flue gases. Selective Catalytic Reduction (SCR) or Selective Non-Catalytic Reduction (SNCR) is employed, and in the following types of power station relevant quantities of ammonia, ammonia solution, or urea are used (Dr M. Ruhrberg, *Bundesverband der Energie and Wasserwirtschaft*, written communication 4.4.2018):

- “- Coal-fired power stations with wet flue gas scrubbing and SCR. The amount of ammonia deployed differs between slag-tap furnaces and pulverized coal-fired furnaces. In view of the higher untreated flue gas concentrations, slag-tap furnaces usually consume more ammonia than pulverized coal-fired furnaces. Power stations with fluidized bed combustion and grate firing which have a thermal rating of less than 100 MW are usually able to comply with the NO<sub>x</sub> limit values solely without using ammonia. The same applies for all lignite-fired power stations, which do not usually have secondary reduction measures.
- Waste incineration plants (SCR, SNCR) and waste wood power plants (SNCR), approved in accordance with the 17th Federal Ambient Pollution Ordinance – with the exception of some plants that operate with fluidized bed combustion.
  - Boilers and heating power stations that are fired with heavy oil and other mineral-oil products (SCR).
  - Compression ignition engines using light heating oil, diesel fuel, or natural gas or other gases (SCR, but usually only for short operating periods and involving negligible quantities).

In addition, individual boilers and gas-fired engines using light heating oil or gas fuel have SCR or SNCR. However, the material flows involved are probably not yet significant for the period 2010 to 2014. With the implementation of the new EU requirements for large and medium-sized combustion plants, this could change in the medium term, because the new NO<sub>x</sub> requirements could make it necessary to employ SCR or SNCR more widely in future.

Coal-fired power stations with fluidized bed combustion and grate firing with a thermal capacity less than 100 MW are usually able to comply with NO<sub>x</sub> limit values without using ammonia. The same applies for lignite-fired power stations, which as a rule do not use secondary reduction measures.” (Prof A. Kather, TU Hamburg-Harburg; written communication, 29 March 2018).

Central statistics on NH<sub>3</sub> consumption for reducing the nitrogen oxide concentration in flue gases in power stations in Germany are not known. For the denoxing of coal-fired power station emissions, the following expert opinion was provided (R. Beckers, UBA, written communication, 3 April 2018): “According to the results of a UBA research project, as an example a coal block with slag-tap furnace (high untreated emissions of NO) was found to require approx. 2 t NH<sub>3</sub>/h (Rentz et al., 2002, Section 5.3.7); assuming 4000 h/a this gives an annual consumption of 8000 t NH<sub>3</sub> (thermal rating 1892 MW; electric output 702 MW). A plant of a similar size with pulverized coal-fired furnaces consumes 600 kg NH<sub>3</sub>/h (Rentz et al., 2002, Section 5.3.5), and therefore again assuming 4000 h/a it uses ~2400 t NH<sub>3</sub> (thermal rating: 1820 MW, 750 MW el.). In Germany in 1995, there were 136 coal-fired power station blocks with SCR in operation with an output of 35,000 MW<sub>el</sub>. Taking a mean of 3000 t NH<sub>3</sub>/a for a 700 MW<sub>el</sub> block and 4000 h/a, then 35,000 MW<sub>el</sub> would have required 50 x 3000 t = 150 kt NH<sub>3</sub> in 1995. Over the period 2010 to 2014 there were fewer coal-fired power station blocks, but at the same time the existing plants had to comply with stricter limit values than the 200 mg/m<sup>3</sup> that had previously applied (relative to 6 vol.% O<sub>2</sub> as a daily mean). As a rough estimate, therefore, 100 kt NH<sub>3</sub> [corresponding to approx. 85 kt N] per year of ammonia is consumed for the denoxing of flue gases.”

#### 4.1.5 Oxidation/reduction of nitrogen by combustion and denoxing (EF.EC-SINK-N2)

It is assumed that the from the combustion of fuels containing nitrogen results in solid and liquid residues (ashes, filter dust, wastewater, etc.) that are virtually free of nitrogen. This means that the N<sub>r</sub> contained in fuels is completely converted to NO<sub>x</sub> and N<sub>2</sub> (in power stations with fluidized bed combustion and in vehicles with SCR catalytic converters N<sub>2</sub>O can also be formed, but this is not quantified here). The extraction and combustion of fuels and the refining of crude oil are therefore regarded in the following as N<sub>r</sub>-neutral processes. In Tab. 4-6, the quantity of N<sub>r</sub> is estimated which is converted to N<sub>2</sub> in the sub-pool “Energy Conversion” in the course of the combustion of fuels.

In total, the domestic extraction and the net import of fossil fuels (lignite, coal, crude oil) for energetic uses brings 2335 kt N<sub>r</sub> a<sup>-1</sup> into circulation (Tab. 4-2). The crude oil is completely refined to mineral-oil products, but with a difference of 818 kt N a<sup>-1</sup> between the N-contents of the crude oil and the N-contents of the resultant mineral-oil products (Tab. 4-3). It is not possible at present to make a fully comprehensive statement about what happens to the N(org) from crude oil (cf. Section 4.1.1). There remains 1517 kt N a<sup>-1</sup> from the combustion of fossil fuels (lignite, coal, mineral-oil products), plus a small amount from wood used as fuel. It is estimated that in the course of combustion a further 188 kt N a<sup>-1</sup> is emitted as non-thermal NO<sub>x</sub>, i.e. the NO<sub>x</sub> comes from the nitrogen compounds in the fuel. This results in a net total of 1417.6 kt N<sub>r</sub> a<sup>-1</sup> that is transformed to N<sub>2</sub> in the course of the combustion of fossil fuels.

Table 4-6: Estimate of the N<sub>r</sub> quantities oxidised or reduced to N<sub>2</sub> during the combustion of fossil fuels and wood (in large combustion plants) and the denoxing of flue gases, annual mean for 2010 – 2014.

| Description   | N-species       | N-flow<br>kt N a <sup>-1</sup> |
|---|-----------------|--------------------------------|
| Combustion of fossil fuels (lignite, coal, mineral-oil products)                              | N(org)          | 1517.0                         |
| Combustion of wood, large combustion plants (Tab. 4-7)  | N(org)          | 3.6                            |
| Denoxing of flue gases (Section 4.1.4)  | NH <sub>3</sub> | 85.0                           |
| <b>Total Combustion and denoxing</b>  |                 | <b>1605.6</b>                  |
| Newly formed non -thermal NO <sub>x</sub> (Section 4.1.2)                                     | NO <sub>x</sub> | - 188.0                        |
| <b>Net oxidation/reduction of N<sub>r</sub> to N<sub>2</sub> with combustion and denoxing</b> |                 | <b>1417.6</b>                  |

To simplify the structure of the NNB, the formation of non-thermal NO<sub>x</sub> is allocated solely to the sub-pool “Energy Conversion” (N-flow EF.EC-SINK(AT)-N2). For the combustion of bone meal (Tab. 5-5), wood (in private households, Tab. 6-3), sludge (Tab. 9-6) and waste (Tab. 9-3) it is assumed that the entire N(org) that these contain is converted to N<sub>2</sub>.

## 4.2 Sub-pools “Manufacturing Industries and Construction” (EF.IC), “Transport” (EF.TR) and “Other Energy and fuels” (EF.OE)

The sub-pool “Manufacturing Industries and Construction” includes the generation of (process)heat and electrical energy by manufacturing companies for the production of goods, including cement manufacturing, smelting of iron and non-ferrous-metals, paper manufacture, food and feed production, etc. Note: the release of N<sub>r</sub> that is not the result of combustion processes is included in the “Material and Products in Industry” pool.

The sub-pool “Transport” covers all the N-flows arising from combustion processes in transport vehicles. In line with the NIR reporting, international marine transport and trans-boundary air travel are not included in the territorial N-balance.

The sub-pool “Other Energy and Fuels” brings together all N-flows from combustion processes in the sectors that are not covered by the other sub-pools. That includes in particular energy conversion in private households (heating), and the fuel consumed by mobile machinery (building sites, agriculture, forest).

In all three sub-pools, the only nitrogen inflows are in the form of inputs with the generation of fuels, and nitrogen outflows are only the gaseous emissions (in sub-pool “Other Energy and Fuels” also

including the inputs with wood for combustion). The inflows have already been determined within the framework of the Energy Balance (see Table 4-2).

### 4.3 Summary of N-flows for the “Energy and Fuels” (EF) pool

Tab. 4-7 shows a summary of the N-flows of the “Energy and Fuels” pool.

Table 4-7: Incoming and outgoing N-flows of the sub-pools of “Energy and Fuels”<sup>a</sup>, annual mean for 2010 – 2014.

| Pool(ex)  | Pool(in) | Flow code          | Description   | N-species  | N-flow<br>kt N a <sup>-1</sup> |
|---|----------|--------------------|---|--|--------------------------------|
| <b>Sub-Pool “Energy Conversion” (EF.EC)</b>                                     |          |                    |   |  |                                |
| SOURCE <sup>a</sup>   | EF.EC    | SOURCE-EF.EC-fuel  | Domestic extraction of fossil fuels   | N(org)   | 694.4                          |
| SOURCE  | EF.EC    | SOURCE-EF.EC-gasEM | Formation of thermal NO <sub>x</sub>  | NO <sub>x</sub>  | 30.0                           |
| MP.FP   | EF.EC    | MP.FP-EF.EC-fuel   | Agricultural products to produce fuels  | N(org)   | 123.7                          |
| MP.NC   | EF.EC    | MP.NC-EF.EC-prod   | NH <sub>3</sub> for denoxing flue gases   | NH <sub>3</sub>  | 85.0                           |
| FS.FO   | EF.EC    | FS.FO-EF.EC-wood   | Wood for energetic use - large combustion plants  | N(org)   | 3.6                            |
| RW  | EF.EC    | RW-EF.EC-fuel      | Import of fossil fuels and mineral-oil products   | N(org)   | 1735.0                         |
| EF.EC   | AT       | EF.EC-AT-N2        | Oxidation/reduction of N <sub>r</sub> to N <sub>2</sub> during combustion and denoxing                          | N <sub>2</sub>   | 1417.6 <sup>a</sup>            |
| EF.EC   | SINK     | EF.EC-SINK-N2      | N <sub>r</sub> loss in the course of crude oil refining   | N <sub>2</sub>   | 818.0                          |
| EF.EC   | AT       | EF.EC-AT-gasEm     | NH <sub>3</sub> , NO <sub>x</sub> and N <sub>2</sub> O emissions from combustion processes in energy conversion | NH <sub>3</sub><br>NO <sub>x</sub><br>N <sub>2</sub> O | 2.2<br>94.3<br>5.9             |
| EF.EC   | EF.IC    | EF.EC-EF.IC-fuel   | Fossil fuels for industry   | N(org)   | 167.8                          |
| EF.EC   | EF.TR    | EF.EC-EF.TR-fuel   | Fossil fuels for use in Transport   | N(org)   | 31.7                           |
| EF.EC   | EF.TR    | EF.EC-EF.TR-fuel   | Fossil fuels for use in households, trade and commerce  | N(org)   | 17.2                           |
| EF.EC   | MP.FP    | EF.EC-MP.FP-prod   | Residues from producing fuels from agricultural products  | N(org)   | 123.7                          |
| EF.EC   | MP.NC    | EF.EC-MP.NC-prod   | Crude oil and mineral-oil products as resources for the chemical industry                                       | N(org)   | 32.1                           |
| EF.EC   | WS.SW    | EF.EC-WS.SW-waste  | Waste from the production of fuels and refinery products  | N(org)   | 1.6                            |
| EF.EC   | WS.WW    | EF.EC-WS.WW-sewage | Wastewater from Energy Conversion   | N(org)   | 8.1                            |
| EF.EC   | RW       | EF.EC-RW-fuel      | Export of fossil fuels and refinery products  | N(org)   | 62.7                           |
| <b>Sub-Pool “Manufacturing Industries and Construction” (EF.IC)<sup>a</sup></b> |          |                    |   |  |                                |
| EF.EC   | EF.IC    | EF.EC-EF.IC-fuel   | Fossil fuels for industry   | N(org)   | 167.8                          |

| Pool(ex)   | Pool(in) | Flow code          | Description  | N-species  | N-flow<br>kt N a <sup>-1</sup> |
|--|----------|--------------------|--|--|--------------------------------|
| EF.IC  | AT       | EF.IC-AT-gasEm     | NH <sub>3</sub> , NO <sub>x</sub> and N <sub>2</sub> O emissions from combustion processes in Manufacturing and Construction | NH <sub>3</sub><br>NO <sub>x</sub><br>N <sub>2</sub> O | 0.8<br>29.4<br>1.7             |
| <b>Sub-Pool “Transport” (EF.TR)<sup>a</sup></b>              |          |                    |  |  |                                |
| EF.EC  | EF.TR    | EF.EC-EF.TR-fuel   | Fossil fuels for use in Transport  | N(org)   | 31.7                           |
| SOURCE   | EF.TR    | SOURCE-EF.TR-gasEM | Formation of thermal NO <sub>x</sub>   | NO <sub>x</sub>  | 159.6                          |
| EF.TR  | AT       | EF.TR-AT-gasEm     | NH <sub>3</sub> , NO <sub>x</sub> and N <sub>2</sub> O emissions from combustion processes in Transport                      | NH <sub>3</sub><br>NO <sub>x</sub><br>N <sub>2</sub> O | 11.5<br>159.6<br>3.0           |
| <b>Sub-Pool “Other energy and fuels” (EF.OE)<sup>a</sup></b> |          |                    |  |  |                                |
| EF.EC  | EF.OE    | EF.EC-EF.OE-fuel   | Fossil fuels for use in households, trade and commerce   | N(org)   | 17.2                           |
| SOURCE   | EF.OE    | SOURCE-EF.OE-gasEM | Formation of thermal NO <sub>x</sub>   | NO <sub>x</sub>  | 2.2                            |
| FS.FO  | EF.OE    | FS.FO-EF.OE-wood   | Wood for domestic energetic use  | N(org)   | 14.6                           |
| EF.OE  | AT       | EF.OE-AT-gasEm     | NH <sub>3</sub> , NO <sub>x</sub> and N <sub>2</sub> O emissions from combustion processes in Energy Conversion              | NH <sub>3</sub><br>NO <sub>x</sub><br>N <sub>2</sub> O | 1.9<br>44.0<br>1.1             |

<sup>a</sup> A flow EF.XX-SINK(AT)-N<sub>2</sub> ought to be included for each of the sub-pools EF.EC, EF.TR and EF.OE. However, the consumption of fuels in the Energy Balance cannot always be reliably allocated between them (cf. Tab. 4-2). As a simplification, the entire amount of the N<sub>r</sub>-oxidation/reduction to N<sub>2</sub> during combustion processes and denoxing is attributed to the sub-pool EF.EC.

#### 4.4 Balance and comments for the “Energy and Fuels” (EF) pool

Tab. 4-8 shows nitrogen inflows and outflows in the “Energy and Fuels” pool. With a difference of (only) ~30 kt N a<sup>-1</sup>, corresponding to ~1 % of N-inflow, the budget seems quite well balanced. However, this is primarily due to the fact that both key nitrogen outflows are calculated as differences, namely the oxidation/reduction of N<sub>r</sub> to N<sub>2</sub> in combustion processes (Section 4.1.5) and the N<sub>r</sub> “loss” with crude oil refining (Section 4.1.1). Not enough is known about what is actually happening in the processes. In the course of our investigations, it was not possible to clarify whether the difference between the nitrogen in the fuels and the N<sub>r</sub> emissions as a result of combustion processes (NO<sub>x</sub>, N<sub>2</sub>O) really correspond to the N<sub>2</sub>-quantities as presented.

Similarly, the discrepancy of 818 kt N a<sup>-1</sup> between the N-contents of the crude oil and the N-contents of the resultant mineral-oil products (see Tab. 4-3) is unconfirmed. Combustion processes do not contribute to this difference, but less is known about the quantitative contribution of crude oil refinery processes to the “loss” of N<sub>r</sub>.

There is a fairly low level of uncertainty about the N-flows into the “Energy and Fuels” pool, which relates primarily to some uncertainty about the N-contents in fuels (coal, lignite, crude oil, and also mineral-oil products). However, there is considerable uncertainty concerning the transformation or the fate of this N<sub>r</sub>. Is it really the case that 2235 kt N a<sup>-1</sup> is converted to molecular N<sub>2</sub> during combustion processes or the refining of crude oil to mineral-oil products? This should be the subject of further investigations.



Table 4-8: Balance of nitrogen inflows and outflows (without agricultural products <sup>a</sup>) in “Energy and Fuels” pool, annual mean for 2010 - 2014.

| Inflow (N <sub>r</sub> -sources)             | kt N a <sup>-1</sup> | Outflow (N <sub>r</sub> )  | kt N a <sup>-1</sup> |
|--|----------------------|--|----------------------|
| Fuels – domestic extraction                  | 694.4                | N <sub>2</sub> O and NO <sub>x</sub> emissions in the atmosphere                       | - 339.0              |
| Net import of fuels and mineral oil products | 1672.3               | NH <sub>3</sub> emissions into the atmosphere  | - 16.4               |
| Formation of thermal NO <sub>x</sub>         | 191.8                | Oxidation/reduction of N <sub>r</sub> to N <sub>2</sub> during combustion and denoxing | - 1417.6             |
| NH <sub>3</sub> for denoxing of flue gases   | 85.0                 | N <sub>r</sub> loss with crude oil refining  | - 818.0              |
| Wood for energetic use                       | 18.2                 | Crude oil and mineral-oil products for processing in the chemical industry             | - 32.1               |
|  |                      | Waste, wastewater  | - 9.7                |
| <b>Total inflows</b>                         | <b>2661.7</b>        | <b>Total outflows</b>  | <b>- 2632.1</b>      |
| <b>Difference: 29.6</b>                      |                      |  |                      |

<sup>a</sup> N-inflows and N-outflows with agricultural biomass for the production of fuels are identical (see Section 4.1.3) and are not shown here.

<sup>b</sup> Including marine bunkers.

In various tables, “SOURCE” is given as the Pool(ex) for the N-flow resulting from the extraction of fossil fuels in Germany (lignite and coal) and the formation of thermal NO<sub>x</sub>. This term is introduced because the NNB system (ECE 2013) does not provide for the “generation” or introduction of N<sub>r</sub> within a pool – in this case by extraction (reduction of stocks) or in the course of combustion processes. Similarly, the “loss” of N<sub>r</sub> as the result of oxidation/reduction to N<sub>2</sub> in combustion processes is also not yet envisaged in the NNB system and here the term “SINK” is used as Pool(in). In the STAN-diagram of the N-flows (Chapter 12), the “Atmosphere” is the Pool(in) for these inflows.

In contrast to the NNB Annex 1 (ECE 2013), biogas production is not included in the sub-pool “Other Energy and Fuels” of “Energy and Fuels” pool for the German N-flow scheme presented here, but is allocated to the “Agriculture” pool (see Section 7.3).

For future N-flow calculations, we suggest dispensing with the sub-pools for the “Energy and Fuels” pool. These sub-divisions were specified by IPCC (2006) and UNFCCC (EEA 2013d) for the national greenhouse gas emissions inventory, where they are appropriate. However, the only internal N-flows between sub-pools involve the supply of sub-pools “Manufacturing Industries and Construction”, “Transport” and “Other energy and fuels” with fuels from the sub-pool “Energy Conversion”. In view of this, and the fact that the data about fuels and their distribution among the sub-pools are derived collectively from a single statistical source, a sub-division of the pool does not seem appropriate.

## 4.5 Uncertainty assessment for N-flows of “Energy and Fuels” (EF) pool

Tab. 4-9 shows the uncertainties in the calculation of the N-flows for the “Energy and Fuels” pool; further explanations are provided in Section 4.4.

Table 4-9: Uncertainties in the calculation of N-flows for “Energy and Fuels” pool.

| Flow code  | Description   | N-species                          | Uncertainty quantity structure  | Uncertainty Coefficients                   | Level <sup>a</sup> |
|--|---|------------------------------------|---|--|--------------------|
| <b>All Sub-Pools (EF.EC, EF.IC, EF.TR, EF.OE))</b> |   |                                    |   |  |                    |
| SOURCE <sup>b</sup> -EF.EC-fuel<br>RW-EF.EC-fuel   | Imports of fuels and domestic extraction                                  | N(org)                             | Very low  | Low  | 2                  |
| SOURCE <sup>b</sup> -EF.EC-gasEml                  | Formation of thermal NO <sub>x</sub>                                      | NO <sub>x</sub>                    | Process knowledge inadequate; Estimate as placeholder   |  | 4                  |
| MP.NC-EF.EC-prod                                   | NH <sub>3</sub> for flue gas denoxing                                     | NH <sub>3</sub>                    | High (experts' estimates, no statistical data available)  | ---  | 4                  |
| MP.FP-EF.EC-prod<br>EF.EC-MP.FP-prod               | Agricultural products to produce fuels                                    | N(org)                             | Very low  | Very low                                   | 1                  |
| EF.EC-SINK-N2                                      | Oxidation/reduction of N <sub>r</sub> to N <sub>2</sub> during combustion | N <sub>2</sub>                     | Medium; Value calculated as a difference. Assumptions without literature support                                    |  | 3                  |
| EF.EC-SINK-N2                                      | N <sub>r</sub> loss for crude oil refining                                | N <sub>2</sub>                     | High; possible processes unclear, value calculated as a difference between two quantities with uncertain N-contents |  | 4                  |
| EF.XX-AT-gasEM                                     | NO <sub>x</sub> , N <sub>2</sub> O emissions                              | NO <sub>x</sub> , N <sub>2</sub> O | see Tab. 3-11 (NO <sub>x</sub> : low; N <sub>2</sub> O: high)   |  | 2 / 4              |
| EF.XX-AT-gasEM                                     | NH <sub>3</sub> emissions   | NH <sub>3</sub>                    | see Tab. 3-11   |  | 3                  |
| EF.EC-SINK <sup>b</sup> -fuel                      | Combustion of fuels   | N <sub>2</sub> (?)                 | Very low  | High, no information about chem. processes | 4                  |
| EF.EC-SINK <sup>b</sup> -fuel                      | Refining crude oil to mineral-oil products                                | N <sub>2</sub> (?)                 | Very low  | High; no qualified information available   | 4                  |

<sup>a</sup> Level of uncertainty in accordance with Tab. 2-3.

<sup>b</sup> On Pool(ex) “SOURCE” or Pool(in) “SINK” see Section 4.4.



## 5 Materials and Products in Industry (MP)

The “Materials and Products in Industry” pool includes the nitrogen flows associated with the production and material use of products containing nitrogen. The definition is in accordance with the one used in IPCC (2006) and EEA (2013) for the calculation of emissions of greenhouse gases. “Material and Products in Industry” pool is divided into three sub-pools.

- ▶ Food and Feed Processing (Food Processing) (MP.FP)
- ▶ Nitrogen chemistry (MP.NC)
- ▶ Other producing Industry (MP.OP).

The production or conversion of energy resources falls under “Energy and Fuels” (Chapter 4). Tab. 5-1 gives an overview of the relevant nitrogen flows.

Table 5-1: Incoming and outgoing N-flows of the sub-pools in the “Material and Products in Industry” pool

| Pool(ex)   | Pool(in) | Flow code            | Description  | N-species | Chapter |
|--|----------|----------------------|--|-----------|---------|
| <b>Sub-Pool “Food and Feed Processing” (MP.FP)</b> |          |                      |  |           |         |
| EF.EC  | MP.FP    | EF.EC-MP.FP-prod     | Residues from the production of fuels from agricultural products             | N(org)    | 4.1.3   |
| AG.AH  | MP.FP    | AG.AH-MP.FP-animProd | Animal market products   | N(org)    | 7.1.1   |
| AG.AH  | MP.FP    | AG.AH-MP.FP-fish     | Produce of aquaculture and inland fisheries                                  | N(org)    | 7.1.2   |
| AG.SM  | MP.FP    | AG.SM-MP.FP-crop     | Vegetable products   | N(org)    | 7.2.1   |
| HY.CW  | MP.FP    | HY.CW-MP.FP-fish     | Landings of coastal and deep-sea fishing                                     | N(org)    | 10.2.4  |
| RW   | MP.FP    | RW-MP.FP-prod        | Imports of food and feed   | N(org)    | 5.1.5   |
| MP.FP  | EF.EC    | MP.FP-EF.EC-fuel     | Agricultural products to produce fuels                                       | N(org)    | 4.1.3   |
| MP.FP  | MP.OP    | MP.FP-MP.OP-crop     | Crops for use in industrial production                                       | N(org)    | 5.1.3   |
| MP.FP  | HS.HB    | MP.FP-HS.HB-food     | Food for human consumption   | N(org)    | 5.1.1   |
| MP.FP  | HS.HB    | MP.FP-HS.HB-feed     | Feed for pets (dogs, cats)   | N(org)    | 5.1.2   |
| MP.FP  | AG.AH    | MP.FP-AG.AH-feed     | Feed for animal husbandry (domestic produce and imports)                     | N(org)    | 7.1.1   |
| MP.FP  | AG.SM    | MP.FP-AG.SM-orgFert  | Bone meal – Use as organic fertiliser  | N(org)    | 5.1.4   |
| MP.FP  | AG.SM    | MP.FP-AG.SM-seed     | Production of agricultural seed and planting stock (not produced internally) | N(org)    | 7.2.1   |
| MP.FP  | AG.BP    | MP.FP-AG.BP-cosub    | Biogas co-substrate (non-agricultural biomass)                               | N(org)    | 7.3     |
| MP.FP  | WS.SW    | MP.FP-WS.SW-fuel     | Bone meal - Thermal recycling  | N(org)    | 5.1.4   |
| MP.FP  | WS.WW    | MP.FP-WS.WW-sewage   | Wastewater from Food and Feed Processing                                     | N(org)    | 9.2.1   |
| MP.FP  | RW       | MP.FP-RW-prod        | Export of food and feed  | N(org)    | 5.1.6   |

| Pool(ex)   | Pool(in) | Flow code           | Description   | N-species                             | Chapter        |
|--|----------|---------------------|---|---------------------------------------|----------------|
| <b>Sub-Pool “Nitrogen Chemistry” (MP.NC)</b>         |          |                     |   |                                       |                |
| SOURCE <sup>a</sup>                                  | MP.NC    | SOURCE-MP.NC-NH3    | Ammonia synthesis (Haber-Bosch process)   | NH3                                   | 5.2.1          |
| EF.EC  | MP.NC    | EF.EC-MP.NC-fuel    | Crude oil and refinery products as resources for the chemical industry                  | N(org)                                | 4.1.1          |
| RW   | MP.NC    | RW-MP.NC-prod       | Import of products of the Nitrogen chemistry  | NH3, NO3<br>N(org)                    | 5.2.2          |
| MP.NC  | AT       | MP.NC-AT-gasEm      | NO <sub>x</sub> and N <sub>2</sub> O emissions from the chemical industry               | NO <sub>x</sub> ,<br>N <sub>2</sub> O | 3.2.1          |
| MP.NC  | AT       | MP.NC-AT-gasEm      | NH <sub>3</sub> emission from the chemical industry                                     | NH3                                   | 3.2.1          |
| MP.NC  | EF.EC    | MP.NC-EF.EC-prod    | NH <sub>3</sub> for denoxing flue gases   | NH3                                   | 4.1.4          |
| MP.NC  | MP.OP    | MP.NC-MP.OP-prod    | Chemicals and products for the production of consumer goods (except mineral fertiliser) | NH3, NO3<br>N(org)                    | 5.2.2          |
| MP.NC  | HS.MW    | MP.NC-HS.MW-minFert | N-Mineral fertiliser for use in kitchen gardens   | NH3, NO3<br>N(org)                    | 5.2.3          |
| MP.NC  | AG.SM    | MP.NC-AG.SM-minFert | N-Mineral fertiliser for use in agriculture   | NH3, NO3<br>N(org)                    | 7.2.1<br>5.2.3 |
| MP.NC  | WS.WW    | MP.NC-WS.WW-sewage  | Wastewater from Nitrogen chemistry  | N(org)                                | 9.2.1          |
| MP.NC  | RW       | MP.NC-RW-prod       | Export of products of Nitrogen chemistry  | NH3, NO3<br>N(org)                    | 5.2.2          |
| <b>Sub-Pool “Other Products in Industry” (MP.OP)</b> |          |                     |   |                                       |                |
| MP.FP  | MP.OP    | MP.FP-MP.OP-crop    | Crops for use in industrial production  | N(org)                                | 5.1.3          |
| MP.NC  | MP.OP    | MP.NC-MP.OP-prod    | Chemicals and products for the production of consumer goods                             | N(org)                                | 5.2.3          |
| FS.FO  | MP.OP    | FS.FO-MP.OP-wood    | Wood for material use   | N(org)                                | 8.1.5          |
| WS.SW  | MP.OP    | WS.SW-MP.OP-waste   | Recycling of waste materials  | N(org)                                | 9.1.2          |
| RW   | MP.OP    | RW-MP.OP-prod       | Import of consumer goods containing nitrogen  | N(org)                                | 5.3            |
| MP.OP  | AT       | MP.OP-AT-gasEm      | NO <sub>x</sub> and N <sub>2</sub> O emission from Other producing industry             | NO <sub>x</sub> ,<br>N <sub>2</sub> O | 3.2.1          |
| MP.OP  | AT       | MP.OP-AT-gasEm      | NH <sub>3</sub> emissions from Other producing industry                                 | NH3                                   | 3.2.1          |
| MP.OP  | HS.MW    | MP.OP-HS.MW-prod    | Production of (nitrogenous) consumer goods  | N(org)                                | 5.3            |
| MP.OP  | WS.SW    | MP.OP-WS.SW-waste   | Waste from Other producing industry   | N(org)                                | 9.1.1          |
| MP.OP  | WS.WW    | MP.OP-WS.WW-sewage  | Wastewater from Other producing industry  | N(org)                                | 9.2.1          |
| MP.OP  | RW       | MP.OP-RW-prod       | Export of consumer goods containing N   | N(org)                                | 5.3            |

<sup>a</sup> On SOURCE see Section 5.6.

The structure of the statistical data on waste disposal (see Section 9.1.1) means that N-flows into the sub-pool “Solid Waste” cannot be calculated for waste materials from the sub-pools “Food and Feed Processing” and “Nitrogen chemistry”. It is assumed that these quantities are contained (predominantly) in the N-flow from the sub-pool “Other Producing Industry” (MP.OP-WS.SW-waste). Furthermore, in the absence of better data, the N-flow from the recycling of waste materials is also only allocated to the sub-pool “Other Producing Industry”, although it is probable that the treatment of nitrogenous waste materials also takes place in the chemical industry (sub-pool “Nitrogen Chemistry”).

## 5.1 Sub-pool “Food and Feed Processing” (MP.FP)

The sub-pool “Food and Feed Processing” includes all N-flows associated with the industrial production or preparation of food and consumables for humans, as well as feed for agricultural livestock and pets.

### 5.1.1 Foodstuffs for human consumption (MP.FP-HS.HB-food)

The Annual Statistics on Food, Agriculture and Forests provides a summarised overview of data for the consumption of food. Tab. 5-2 presents a summary of the results for some 40 categories contained in the original table (BMEL 2016, Tab. 207). Details of food production quantities are also contained in the Production Survey of the Federal Statistical Agency (DESTATIS 2018), but the amounts of produce for sale are not always explicit, and data for many items is withheld there for reasons of confidentiality.

Table 5-2: Nitrogen flow with the consumption of foodstuffs – shown in produce groups (BMEL 2016, Tab. 207), annual mean for 2010 – 2014.

| Produce group                             | Amount<br>1000 t | N-contents <sup>a</sup><br>% | N-flow<br>t N a <sup>-1</sup> |
|---|------------------|------------------------------|-------------------------------|
| Cereals                                   | 6,963            | 2.2 <sup>b</sup>             | 151.1                         |
| Rice, pulses, potatoes                    | 5,507            | 0.4 <sup>b</sup>             | 23.4                          |
| Sugar, glucose, iso-glucose, honey, cocoa | 3,993            | 0.2 <sup>b</sup>             | 8.7                           |
| Fruit and vegetables                      | 16,934           | 0.2 <sup>b</sup>             | 32.7                          |
| Meat and meat products (slaughter weight) | 7,249            | 2.7 <sup>c</sup>             | 195.1                         |
| Fish and fish products (round weight)     | 1,196            | 2.8 <sup>b</sup>             | 33.5                          |
| Milk and milk products                    | 9,770            | 1.4 <sup>b,d</sup>           | 133.3                         |
| Oils and fats                             | 1,682            | 0.0 <sup>d</sup>             | 0.5                           |
| Eggs and egg products                     | 1,103            | 1.9 <sup>d</sup>             | 21.0                          |
| <b>Total</b>                              | <b>54,397</b>    |                              | <b>599.4</b>                  |

<sup>a</sup> N-contents as a mean for the produce group.

<sup>b</sup> N-contents according to NNB Annex 6, Table 12 (ECE 2013).

<sup>c</sup> N-contents according to the Materials Flow Balance Ordinance (2017), Annex 1, Tab. 5.

<sup>d</sup> N-contents after Souci, Fachmann, Kraut - Database online (www.sfk.online, accessed 6.4.2018).

Details on the use of agricultural produce are also provided in the Annual Statistics on Food, Agriculture and Forests (BMEL 2016) under “Supply with ...” and “Use of ...” (Tab. 221 to Tab. 311), which give quantities under the heading “Domestic Use” for “Food”. However, these tables are complex and it is not always clear which figures actually show sales to consumers.

The N-flow of some 600 kt N a<sup>-1</sup> from the consumption of food corresponds to a daily protein supply of ~125 grams protein per capita (gross, before deducting losses from processing, trade, in households, and during cooking). This value is plausible in the light of the recommended daily protein intake of 0.8 to 1 gram per kg body weight or 60 to 80 grams per adult per day (German Food Association).

### 5.1.2 Feed for pets (MP.FP-HS.HB-feed)

The N-flow via feed for dogs and cats is estimated on the basis of NNB Annex 6, Formel 0.9 (ECE 2013). The relatively small amounts of feed required for other pets (small pets, cage birds, aquaria, terraria) are not included (Tab. 5-3).

Table 5-3: Nitrogen flow with feed for dogs and cats, annual mean for 2012 - 2014.

| Pet           | No. of animals <sup>a</sup><br>x 1000 | Consumption<br>kg pet <sup>-1</sup> a <sup>-1</sup> | N-contents<br>% | N-flow<br>kt N a <sup>-1</sup> |
|---------------|---------------------------------------|---|-----------------|--------------------------------|
| Dogs          | 6,800                                 | 163.3   | 2.88            | 32.2                           |
| Cats          | 11,800                                | 73.0  | 4.16            | 35.8                           |
| <b>Totals</b> | <b>18,600</b>                         |   |                 | <b>68.0</b>                    |

<sup>a</sup> Source: *Industrieverband Heimtierbedarf* (2018); continuous data only available for 2012 - 2014.

<sup>b</sup> After NNB Annex 6, Table 18 (ECE 2013).

The Annual Statistics on Food, Agriculture and Forests 2015 (BMEL 2015, Tab. 330) also include data on the production of dog food and cat food. Using these figures (with the N-contents in accordance with Tab. 5-3) would give a lower N-flow for pet food of 44.9 kt N a<sup>-1</sup>. The discrepancy to the N-flow in Tab. 5-3 can be explained at least in part by the fact that dogs and cats are also given self-prepared feed. According to the study “Pet Food Trends in Germany” (Department of Agriculture and Agri-Food Canada 2018), sales of dog and cat food in Germany amount to 960,000 t (annual mean, 2010 - 2014). Again using the N-contents in accordance with Tab. 5-3, this would correspond to a much lower N-flow of 34.6 kt N, which is not used for the nitrogen balance.

### 5.1.3 Crops as industrial resources (MP.FP-MP.OP-crop)

The Annual Statistics (BMEL 2016, Tab. 91) give the areas farmed for crops as industrial resources (mainly industrial starch and technical rape-seed oil), with the exception of energy crops (see Section 4.1.3). N-flows (Tab. 5-4) are calculated using the mean crop yields.

Table 5-4: Nitrogen flow with crops as industrial resources (without energy crops), annual mean 2012 – 2014 (BMEL 2016, Tab. 91).

| Product/Use                                  | Cropping area<br>1000 ha | Yield<br>dt ha <sup>-1</sup> | N-content<br>%   | N-flow<br>kt N a <sup>-1</sup> |
|--|--------------------------|------------------------------|------------------|--------------------------------|
| Industrial starch (calculated as corn maize) | 112.6                    | 100.0                        | 1.4              | 15.1                           |
| Industrial sugar (sugar beet)                | 14.1                     | 674.0                        | 0.18             | 1.8                            |
| Technical rape-seed oil                      | 130.2                    | 37.9                         | 3.35             | 16.1                           |
| Technical sunflower oil                      | 7.4                      | 32.3 <sup>a</sup>            | 2.9              | 0.6                            |
| Technical linseed oil                        | 3.6                      | 24.3 <sup>a</sup>            | 3.5              | 0.3                            |
| Plant fibres (calculated as fibre flax)      | 0.7                      | 100.0 <sup>a</sup>           | 1.0              | 0.1                            |
| Pharmaceuticals and dyes                     | 10.8                     | 10.0 <sup>a</sup>            | 1.0 <sup>a</sup> | 0.1                            |
| <b>Totals</b>                                | <b>279.4</b>             |                              |                  | <b>34.2</b>                    |

<sup>a</sup> Estimated.

### 5.1.4 Rendering of animal by-products

Every year ~2.9 million t animal by-products are rendered, e.g. meat and bones that are not used as food for humans. Animal by-products are placed in three categories:

- C1:** Animals that died from diseases.
- C2:** Animals that died for other reasons apart from diseases or slaughter or that were not accepted for slaughter.
- C3:** By-products from slaughter and meat processing that are not used for human consumption for economic reasons, or residues after slaughter and processing.

The German Animal By-products Service Company publishes annual statistics on the amounts of animal by-products and their rendering (Niemann, various years), Tab. 5-5 shows the N-flows quantities for the various categories and uses.

Table 5-5: Rendering of animal by-products – Proteins <sup>a</sup> (mean 2011 - 2014<sup>b</sup>) and N-flows according to use and category (Source: Niemann; various years).

| Flow code                        | Use                        | Products (t) |        |         | N-flow (kt N a <sup>-1</sup> ) |     |      |                         |
|----------------------------------|----------------------------|--------------|--------|---------|--------------------------------|-----|------|-------------------------|
|                                  |                            | Category     |        |         | Category <sup>c,d</sup>        |     |      |                         |
|                                  |                            | C1           | C2     | C3/F    | C1                             | C2  | C3/F | Total                   |
| MP.FP-AG.SM-orgFert <sup>e</sup> | Technical use (fertiliser) |              | 30,889 | 140,493 |                                | 2.7 | 10.1 | <b>12.8<sup>e</sup></b> |
| MP.FP-WS.SW-fuel                 | Thermal recycling          | 213,773      | 87     | 660     | 18.8                           | 0.0 | 0.0  | <b>18.8</b>             |
| (in MP.FP in-farm processing)    | Feed                       |              |        | 294,084 |                                |     | 21.2 | <b>21.2</b>             |

<sup>a</sup> Animal fats are virtually N-free and are not included.

<sup>b</sup> Data for 2010 not included due to changes in the data structure.

<sup>c</sup> The categories are explained in the text.

<sup>d</sup> N-contents: C1, C2: 8.8 % N; C3: 7.2 % N (Source: [www.stn-vvt.n.de/produkte.php](http://www.stn-vvt.n.de/produkte.php)).

<sup>e</sup> The N-budget for agriculture (see Section 7.2.1) shows 13.6 kt N a<sup>-1</sup>.

Animal protein cannot be fed to agricultural livestock in the European Union, and so it is mainly used in pet food. Technical uses relate to the sale as fertiliser. Thermal recycling refers to use as a fuel in combustion plants, but since it can be presumed that this is primarily for reasons of waste disposal, this N-flow is included under “Solid Waste” sub-pool rather than “Energy Conversion”.

### 5.1.5 Imports and exports for the food industry (RW-MP.FP-prod, MP.FP-RW-prod)

Tab. 5-6 shows imports and exports of the food industry according to the Annual Statistics on Food, Agriculture and Forests (BMEL 2016, Tab. 395, Tab. 245). As with Table 5-2, N-contents for some 40 individual products in the source tables (BMEL 2016, Tab. 395 and Tab. 245) are summarised in groups. Data for the imports of animal feed were taken from the table of “Feed supplies in agriculture from imports”, which already shows net imports (BMEL 2016, Tab. 122). There are two reasons for this choice: (i) Regarding the imports of feed we find the figures in the feed supply statistics more plausible and more complete than those in the food industry imports and exports; (ii) The balance of BMEL for agriculture uses these figures for feed supplies from domestic production (BMEL 2016, Tab. 121) and from imports (Tab. 122).

Table 5-6: Imports and exports of the food industry and net imports of animal feed, annual mean 2012 – 2014 (BMEL 2016).

| Group   | Imports<br>1000 t | Exports<br>1000 t | N-<br>contents<br>% <sup>a</sup> | Imports<br>kt N a <sup>-1</sup> | Exports<br>kt N a <sup>-1</sup> |
|---|-------------------|-------------------|----------------------------------|---------------------------------|---------------------------------|
| Grains and grain products (including rice)    | 11,328            | 15,100            | 2.0                              | 227.6                           | 342.1                           |
| Potatoes and potato products                  | 1,202             | 2,487             | 0.6                              | 6.7                             | 10.3                            |
| Sugar and cocoa                               | 2,754             | 895               | 0.6                              | 16.0                            | 15.5                            |
| Fruit and fruit products                      | 8,358             | 4,050             | 0.1                              | 9.7                             | 4.0                             |
| Vegetables, spices, seeds, etc.               | 6,057             | 1,372             | 0.3                              | 20.5                            | 5.0                             |
| Beer (1000 hl)                                | 7,115             | 15,618            | 0.1                              | 7.1                             | 15.6                            |
| Oleaginous fruits, oils and fats              | 10,590            | 2,645             | 0.0                              | 0.1                             | 0.1                             |
| Dairy products (excluding butter)             | 3,844             | 5,916             | 1.7                              | 66.7                            | 86.6                            |
| Eggs, honey                                   | 630               | 186               | 1.7                              | 10.4                            | 3.2                             |
| Animals for slaughter, meat and meat products | 2,978             | 4,252             | 3.1                              | 93.1                            | 130.6                           |
| Fish and fish products                        | 953               | 562               | 2.5                              | 23.8                            | 13.2                            |
| Living animals (not for immediate slaughter)  | <sup>b</sup>      | <sup>b</sup>      |                                  | 3.0                             | 9.1                             |
| Feed (net imports)                            |                   |                   |                                  | 405.2 <sup>c</sup>              |                                 |
| <b>Totals Imports and Exports</b>             |                   |                   |                                  | <b>890.0</b>                    | <b>635.2</b>                    |

<sup>a</sup> N-content: see footnote to Tab. 5-2.

<sup>b</sup> Data as numbers of animals.

<sup>c</sup> Taken from the nitrogen balance of BMEL (net N-import).

## 5.2 Sub-pool “Nitrogen Chemistry” (MP.NC)

The sub-pool “Nitrogen Chemistry” relates to the production and processing of a wide range of nitrogenous chemicals, fertilisers, chemical fibres, plastics in primary forms, plant protection products, pharmaceuticals, etc. (on the classification of the economic sectors cf. DESTATIS 2008).

### 5.2.1 Ammonia synthesis (SOURCE-MP.NC-NH3)

The key factor in the “Materials and Products in Industry” pool is ammonia synthesis by means of the Haber-Bosch process. The conversion of N<sub>2</sub> to NH<sub>3</sub> represents by far the largest primary anthropogenic N-input in the N-cycle. Relatively small amounts of N<sub>2</sub> are also converted to a reactive form through the synthesis of calcium cyanamide (CaCN<sub>2</sub>).

- ▶ Ammonia synthesis, annual mean for 2010 - 2014 (after VCI, 2017): 2673.6 kt N a<sup>-1</sup>
- ▶ Calcium cyanamide synthesis, annual mean for 2010 – 2014, approx. 21.0 kt N a<sup>-1</sup>.

### 5.2.2 Production, import and export of chemicals (MP.NC-MP.OP-prod, RW-MP.NC-prod, MP.NC-RW-prod)

The main source of statistics on production quantities for Germany is the Production Survey (DESTATIS 2017a, Tab. 42131-0003), which provides details for commodity groups. The Production Survey also distinguishes between initial products and products “intended for sale”. However, evaluating the Production Survey raises considerable problems:

- ▶ It is not possible to rule out double counting in the statistics. All products that are *not* “intended for sale” are initial products for further processing, but these may re-occur in a number of further production steps. For example, ammonia is registered initially in the primary synthesis, then as ammonia in aqueous solutions, then again in the polyamides it is used to produce, etc.
- ▶ Also items which are “intended for sale” may nevertheless be used as initial products in other production processes.
- ▶ For various types of goods, the data on production quantities and/or the amounts intended for sale are not published for reasons relating to data protection.

In order to register the N-flow from the chemical industry (Tab. 5-7), the production quantities “intended for sale” from the Production Survey were evaluated. At first the figures from the Production Survey were grouped together in accordance with the classification of commodities (conversion table, Eurostat, no date), as used in the import and export statistics (at the 4-figure code level). The production quantities can then be linked directly to the imports and exports. As far as possible, a typical chemical compound is taken for each commodity group, and the N-contents for the overall group is calculated on this basis.

In the Production Survey, some products are not unequivocally identifiable as “fertiliser”, and therefore figures for the commodity group of N-fertiliser were taken from the Agricultural Industry Association (IVA 2017).

Note: The primary production of ammonia is not listed in Tab. 5-7, because the N-quantities of all other items in the Production Survey are derived from this (see Section 5.2.1). At least here, double counting is avoided.

The import and export quantities of chemicals containing nitrogen were taken from the Foreign Trade Statistics (DESTATIS 2015a, Tab. 51000-0005).

Tab. 5-7 show a total of 3072 kt N a<sup>-1</sup> in the products of the chemical industry “intended for sale”. This is about 14 % more than the 2695 kt primary NH<sub>3</sub>-N a<sup>-1</sup> provided by ammonia synthesis. This difference can be attributed to possible double counting as well as to uncertainties in the assumptions about the N-contents of the product groups.

Due to the problems encountered with evaluating the production survey, the N-flow with the initial products from the chemical industry into the sub-pool “Other Producing Industry” (MP.NC-MP.OP-prod) cannot be determined directly from the statistics. This N-flow is therefore calculated as a difference, starting with the total N<sub>r</sub> of 3192 kt N a<sup>-1</sup> entering into the chemical industry. This amount is made up of 2695 kt N a<sup>-1</sup> from NH<sub>3</sub> synthesis, the trade balance of 466 kt N a<sup>-1</sup> for chemical products (see Tab. 5-7) and 32 kt N a<sup>-1</sup> in the petrochemical products as pre-cursors for organic chemistry. N-flows that clearly leave the chemical industry take the form of the end products fertiliser (1664 kt N a<sup>-1</sup>) and NH<sub>3</sub> for denoxing of flue gases (85 kt N a<sup>-1</sup>), as well as gaseous emissions (18 kt N a<sup>-1</sup>) and wastewater (69 kt N a<sup>-1</sup>). The N-flows amount to 1836 kt N a<sup>-1</sup>. The difference of 1356 kt N a<sup>-1</sup> is then taken to be the N-flow into the sub-pool “Other Producing Industry” for further production.



Table 5-7: Production <sup>a</sup>, import and export of chemicals in sub-pool “Nitrogen Chemistry”, annual mean for 2010 – 2014 (Source: DESTATIS 2015a, 2017a; IVA 2017).

| Group  | Name  | Compound <sup>c</sup>  | Quantity (1000 t)       |        |        | N-contents <sup>b</sup><br>(%) | N-flow (kt N a <sup>-1</sup> ) |        |        |
|--------|---|--|-------------------------|--------|--------|--------------------------------|--------------------------------|--------|--------|
|        |   |  | Production <sup>a</sup> | Import | Export |                                | Production                     | Import | Export |
| 2808   | Nitric acid   | HNO <sub>3</sub>   | 520.6                   | 107.1  | 204.7  | 22.2%                          | 115.7                          | 23.8   | 45.5   |
| 2814   | Ammonia, or ammonia solution                        | NH <sub>3</sub>  | 895.8                   | 575.5  | 413.6  | 82.4%                          | 710.1                          | 473.9  | 340.6  |
| 282510 | Hydrazine, hydroxylamine, and their inorganic salts | N <sub>2</sub> H <sub>4</sub> , NH <sub>2</sub> OH           | 31.4                    | 5.5    | 29.0   | 65.0%                          | 20.4                           | 3.6    | 18.8   |
| 2834   | Nitrite, nitrate                                    | NO <sub>2</sub> , NO <sub>3</sub> <sup>-1</sup>              | n.d.                    | 50.5   | 73.4   | 26.0%                          | n.d.                           | 13.1   | 19.1   |
| 2837   | Cyanide, cyanide oxide and complex cyanides         | HCN  | n.d.                    | 16.2   | 38.4   | 48.3%                          | n.d.                           | 7.8    | 18.6   |
| 2850   | Hydrides, nitrides, azides, silicides and borides   | Li <sub>3</sub> N  | 2.0                     | 1.7    | 0.9    | 40.2%                          | 0.8                            | 0.7    | 0.4    |
| 2904   | Sulpho-derivates, nitro-derivates of hydrocarbons   | H <sub>2</sub> N <sub>2</sub> O <sub>2</sub>                 | 71.5                    | 45.5   | 94.2   | 45.2%                          | 32.3                           | 20.6   | 42.5   |
| 2921   | Compounds with amino function                       | Aniline, etc.  | 278.1                   | 547.0  | 338.4  | <sup>d</sup>                   | 61.6                           | 164.1  | 101.5  |
| 2922   | Amines with oxygen functions                        | C <sub>6</sub> H <sub>14</sub> N <sub>2</sub> O <sub>2</sub> | 140.6                   | 208.8  | 286.6  | 19.2%                          | 27.0                           | 40.0   | 55.0   |
| 2923   | Quaternary organic ammonium salts, lecithin         | C <sub>5</sub> H <sub>14</sub> CINO                          | 36.9                    | 80.1   | 95.3   | 10.0%                          | 3.7                            | 8.0    | 9.5    |
| 2924   | Compounds with carboxamide function                 | CH <sub>3</sub> NO <sub>2</sub>                              | 769.1                   | 65.8   | 89.2   | 23.0%                          | 176.5                          | 15.1   | 20.5   |
| 2925   | Compounds with carbox-imide function                |  | 15.4                    | 15.9   | 15.6   | 10.0%                          | 1.5                            | 1.6    | 1.6    |
| 2926   | Compounds with nitrile function                     | C <sub>3</sub> H <sub>3</sub> N                              | n.d.                    | 107.4  | 101.2  | 26.4%                          | n.d.                           | 28.4   | 26.7   |
| 2928   | Organic derivates of hydrazine, hydroxylamine       | N <sub>2</sub> H <sub>4</sub> , NH <sub>2</sub> OH           | 4.8                     | 8.4    | 5.2    | 65.0%                          | 3.1                            | 5.4    | 3.4    |
| 2929   | Compounds with other nitrogen functions             | HNCO   | 485.8                   | 117.3  | 301.4  | 32.6%                          | 158.2                          | 38.2   | 98.1   |
| 2930   | Organo-sulphur compounds                            | C <sub>5</sub> H <sub>11</sub> NO <sub>2</sub> S             | 148.8                   | 65.3   | 130.4  | 9.4%                           | 13.9                           | 6.1    | 12.3   |
| 2933   | Heterocyclic compounds with nitrogen                | Melamine   | 193.1                   | 353.5  | 304.8  | 47.0%                          | 90.7                           | 166.1  | 143.3  |
| 2934   | Nucleic acid and its salts                          |  | 27.7                    | 18.0   | 43.6   | 16.8%                          | 4.6                            | 3.0    | 7.3    |
| 2935   | Sulphonamides                                       | H <sub>2</sub> NSO <sub>2</sub> NH <sub>2</sub>              | 0.7                     | 5.7    | 1.8    | 29.2%                          | 0.2                            | 1.7    | 0.5    |
| 3402   | Surface-active preparations, detergent              |  | 2828.5                  | 1191.9 | 1681.5 | 2.1%                           | 59.4                           | 25.0   | 35.3   |



| Group  | Name  | Compound <sup>c</sup> | Quantity (1000 t)       |        |        | N-contents <sup>b</sup><br>(%) | N-flow (kt N a <sup>-1</sup> ) |               |               |
|--|---|-----------------------|-------------------------|--------|--------|--------------------------------|--------------------------------|---------------|---------------|
|  |   |                       | Production <sup>a</sup> | Import | Export |                                | Production                     | Import        | Export        |
| 3501   | Casein, caseinate, casein derivatives, casein glue  |                       | 11.6                    | 31.2   | 30.3   | 15.0%                          | 1.7                            | 4.7           | 4.5           |
| 3502   | Albumins, albuminates and other albumin derivatives | Egg protein           | 18.3                    | 16.1   | 28.8   | 16.0%                          | 2.9                            | 2.6           | 4.6           |
| 3503   | Gelatine, glues of animal origins                   |                       | 21.8                    | 31.9   | 26.0   | 15.0%                          | 3.3                            | 4.8           | 3.9           |
| 3504   | Peptones and other proteins, hide powder            | Proteins              | 10.8                    | 31.3   | 31.6   | 16.0%                          | 1.7                            | 5.0           | 5.1           |
| 3507   | Enzymes   |                       | 7.4                     | 343.3  | 25.6   | 15.0%                          | 1.1                            | 51.5          | 3.8           |
| 3908   | Polyamides in primary forms                         |                       | 1016.3                  | 453.7  | 711.9  | 12.0%                          | 122.0                          | 54.4          | 85.4          |
| 3909   | Amino resins, phenol resins, polyurethane           |                       | 1852.7                  | 649.5  | 1090.9 | 10.0%                          | 185.3                          | 64.9          | 109.1         |
| <b>Totals Production, imports and exports of chemicals, excluding fertiliser</b> |   |                       |                         |        |        |                                | <b>1797.7</b>                  | <b>1234.0</b> | <b>1216.9</b> |
| (3102)   | Nitrogenous fertiliser <sup>e</sup>                 | Pure N                | 1274.2                  | 1028.2 | 580.2  | 100.0%                         | 1274.2                         | 1028.2        | 580.2         |
| <b>Totals Production, Imports and exports</b>                                    |   |                       |                         |        |        |                                | <b>3071.9</b>                  | <b>2262.2</b> | <b>1797.1</b> |

n.d.: no data.

<sup>a</sup> Weight of the produce intended for sale.

<sup>b</sup> N-contents: calculated for the compound in Column 3; otherwise, estimated values after NNB Annex 6, Table 13 and Table 16 (ECE 2013).

<sup>c</sup> Representative nitrogen compounds from which N-contents has been calculated.

<sup>d</sup> N-flow calculated for various sub-groups with differing N-contents.

<sup>e</sup> For nitrogenous fertiliser after IVA (2017); mean for fertiliser seasons 2009/10 – 2013/14.

### 5.2.3 Nitrogen-mineral fertiliser (MP.NC-AG.SM-minFert; MP.NC-HS.MV-minFert)

The fertiliser statistics show 1664 kt N a<sup>-1</sup> in mineral fertilisers used for agriculture, and for kitchen gardens, etc. The amount deployed apart from agriculture, i.e. in kitchen gardens, on sports fields, public green spaces, etc., amounts to approx. 45 kt N a<sup>-1</sup> according to the estimates of experts (Agricultural Industry Association (IVA), written communication, 19.3.2018).

In contrast, domestic fertiliser production of 1274 kt N a<sup>-1</sup> (according to IVA 2017) and the trade balance of 448 kt N a<sup>-1</sup> give a combined total of 1722 kt N a<sup>-1</sup>. The difference of 58 kt N a<sup>-1</sup> can possibly be attributed to changes in stores, different reference periods (Sales: mean for calendar years 2010 – 2014; Production and trade: Fertilisation seasons 2009/10 – 2013/14), and to statistical differences.

### 5.3 Sub-pool “Other Producing Industry” (MP.OP)

The sub-pool “Other Producing Industry” includes the production of goods containing nitrogen that are intended for sale (to end consumers) or for export. The N-flows associated with the production (MP.OP-HS.MW-prod), import (RW-MP.OP-prod) and export (MP.OP-RW-prod) of consumer goods are again determined on the basis of the Production Survey (DESTATIS 2017a, Tab. 42131-0003) and are summarised in Tab. 5-8. The problems of double counting and the considerable uncertainties involved in estimating the N-contents already discussed in Section 5.2.2 apply similarly in this case. An additional problem with consumer goods is that the data may be expressed in various units, e.g. numbers of items, square metres, or cubic metres. In such cases, the figures were converted to tonnes, on the basis of an estimated mean weight per unit.

Table 5-8: Production, import and export of nitrogenous commodities, annual mean for 2010 – 2014 (Source: DESTATIS 2015a, 2017a; IVA 2017).

| Production Survey                             |                                    | Amount (1000 t)         |        |        | N-contents <sup>b</sup><br>(%) | N-flow (kt N a <sup>-1</sup> ) |              |              |
|---|------------------------------------|-------------------------|--------|--------|--------------------------------|--------------------------------|--------------|--------------|
| Groups  | Name                               | Production <sup>a</sup> | Import | Export |                                | Production                     | Import       | Export       |
| 24  | Tobacco                            | 249                     | 276    | 272    | 4.0%                           | 9.9                            | 11.0         | 10.9         |
| 41 - 43, 50                                   | Textiles (leather, silk, furs)     | 100                     | 474    | 342    | 15.0%                          | 14.9                           | 71.1         | 51.3         |
| 44xx  | Finished goods (woodworking)       | 17,318                  | 3,497  | 9,790  | 0.14%                          | 24.2                           | 7.0          | 19.6         |
| 47 - 49                                       | Cellulose/Papier                   | 32,559                  | 22,379 | 22,432 | 0.2%                           | 65.1                           | 44.8         | 44.9         |
| 51  | Wool, fine and coarse animal hair  | 4                       | 93     | 67     | 15.0%                          | 0.6                            | 0.2          | 0.1          |
| 52, 53  | Cotton fabric                      | 54                      | 312    | 170    | 0.2%                           | 0.1                            | 0.6          | 0.3          |
| 54, 55  | Synthetic fibres and fabrics       | 335                     | 941    | 890    | 12.0%                          | 40.2                           | 112.9        | 106.8        |
| 56 - 67                                       | Clothing, material, carpets, shoes | 985                     | 3,793  | 2,368  | 0.2%                           | 2.0                            | 56.8         | 70.6         |
| 94xx  | Furniture, lighting, etc.          | 3,063                   | 3,473  | 2,200  | 0.2%                           | 6.1                            | 6.9          | 4.4          |
| <b>Totals: Production, Import, and Export</b> |                                    |                         |        |        |                                | <b>163.2</b>                   | <b>311.4</b> | <b>308.9</b> |

<sup>a</sup> Weight of products intended for sale; all other units are converted to weights on the basis of a mean weight per item.

<sup>b</sup> N-contents: Estimated values according to NNB Annex 6, Table 13 and Table 16 (ECE 2013).

The N-flow with consumer goods from the sub-pool “Other Producing Industry” to the sub-pool “Material World” (MP.OP-HS.MW-prod) corresponds to the (domestic) production of 163.2 kt N a<sup>-1</sup> plus the net imports of 2.5 kt N a<sup>-1</sup>.

## 5.4 Summary of N-flows for Materials and Products in “Industry” (MP) pool

Tab. 5-9 shows a summary of the N-flows for the “Materials and Products in Industry” pool.

Table 5-9: Incoming and outgoing N-contents of the N-flows of the sub-pools in the “Materials and Products in Industry” pool, annual mean for 2010 – 2014.

| Pool(ex)   | Pool(in) | Flow code            | Description  | N-species          | N-flow<br>kt N a <sup>-1</sup> |
|--|----------|----------------------|--|--------------------|--------------------------------|
| <b>Sub-Pool “Food and Feed Processing” (MP.FP)</b> |          |                      |  |                    |                                |
| EF.EC  | MP.FP    | EF.EC-MP.FP-prod     | Residues from the production of fuels from agricultural products             | N(org)             | 123.7                          |
| AG.AH  | MP.FP    | AG.AH-MP.FP-animProd | Animal market products   | N(org)             | 413.5                          |
| AG.AH  | MP.FP    | AG.AH-MP.FP-fish     | Products of aquaculture and inland fisheries                                 | N(org)             | 0.7                            |
| AG.SM  | MP.FP    | AG.SM-MP.FP-crop     | Vegetable products   | N(org)             | 1134.0                         |
| HY.CW  | MP.FP    | HY.CW-MP.FP-fish     | Landings coastal and deep-sea fishing  | N(org)             | 6.3                            |
| RW   | MP.FP    | RW-MP.FP-prod        | Import of food and feed  | N(org)             | 890.0                          |
| MP.FP  | EF.EC    | MP.FP-EF.EC-fuel     | Agricultural products to produce fuels                                       | N(org)             | 123.7                          |
| MP.FP  | MP.OP    | MP.FP-MP.OP-crop     | Crops for use in industrial production                                       | N(org)             | 34.2                           |
| MP.FP  | HS.HB    | MP.FP-HS.HB-food     | Food for human consumption   | N(org)             | 599.4                          |
| MP.FP  | HS.HB    | MP.FP-HS.HB-feed     | Feed for pets (dogs and cats)  | N(org)             | 68.0                           |
| MP.FP  | AG.AH    | MP.FP-AG.AH-feed     | Feed for agricultural livestock from domestic production and imports)        | N(org)             | 1102.2                         |
| MP.FP  | AG.SM    | MP.FP-AG.SM-orgFert  | Bone meal – Use as organic fertiliser  | N(org)             | 12.8                           |
| MP.FP  | AG.SM    | MP.FP-AG.SM-seed     | Production of agricultural seed and planting stock (not produced internally) | N(org)             | 22.2                           |
| MP.FP  | AG.BP    | MP.FP-AG.BP-cosub    | Biogas co-substrate (non-agricultural biomass)                               | N(org)             | 31.4                           |
| MP.FP  | WS.SW    | MP.FP-WS.SW-fuel     | Bone meal - Thermal recycling  | N(org)             | 18.8                           |
| MP.FP  | WS.WW    | MP.FP-WS.WW-sewage   | Wastewater from Food and Feed Processing                                     | N(org)             | 36.3                           |
| MP.FP  | RW       | MP.FP-RW-prod        | Export of food and feed  | N(org)             | 635.2                          |
| <b>Sub-Pool “Nitrogen chemistry” (MP.NC)</b>       |          |                      |  |                    |                                |
| SOURCE <sup>a</sup><br>(AT)                        | MP.NC    | AT-MP.NC-NH3         | Ammonia synthesis (Haber-Bosch process) <sup>b</sup>                         | NH3                | 2694.6                         |
| EF.EC  | MP.NC    | EF.EC-MP.NC-fuel     | Crude oil and refinery products for processing in the chemical industry      | N(org)             | 32.1                           |
| RW   | MP.NC    | RW-MP.NC-prod        | Import of products of Nitrogen chemistry                                     | NH3, NO3<br>N(org) | 2262.2                         |

| Pool(ex)   | Pool(in) | Flow code           | Description   | N-species                                   | N-flow<br>kt N a <sup>-1</sup> |
|--|----------|---------------------|---|---|--------------------------------|
| MP.NC  | AT       | MP.NC-AT-gasEm      | NO <sub>x</sub> and N <sub>2</sub> O emissions from the chemical industry               | NO <sub>x</sub> ,<br>N <sub>2</sub> O       | 8.7<br>2.0                     |
| MP.NC  | AT       | MP.NC-AT-gasEm      | NH <sub>3</sub> emissions from the chemical industry                                    | NH <sub>3</sub>                             | 7.5                            |
| MP.NC  | EF.EC    | MP.NC-EF.EC-prod    | NH <sub>3</sub> for denoxing of flue gases  | NH <sub>3</sub>                             | 85.0                           |
| MP.NC  | MP.OP    | MP.NC-MP.OP-prod    | Chemicals and initial products for producing consumer goods (except mineral fertiliser) | NH <sub>3</sub> , NO <sub>3</sub><br>N(org) | 1356.0                         |
| MP.NC  | HS.MW    | MP.NC-HS.MW-minFert | N-Mineral fertiliser for use in kitchen gardens   | NH <sub>3</sub> , NO <sub>3</sub><br>N(org) | 45.0                           |
| MP.NC  | AG.SM    | MP.NC-AG.SM-minFert | N-Mineral fertiliser for use in Agriculture   | NH <sub>3</sub> , NO <sub>3</sub><br>N(org) | 1619.0                         |
| MP.NC  | WS.WW    | MP.NC-WS.WW-sewage  | Wastewater from Nitrogen chemistry  | N(org)                                      | 68.6                           |
| MP.NC  | RW       | MP.NC-RW-prod       | Export of products of Nitrogen chemistry  | NH <sub>3</sub> , NO <sub>3</sub><br>N(org) | 1797.1                         |
| <b>Sub-Pool "Other Producing Industry" (MP.OP)</b> |          |                     |   |   |                                |
| MP.FP  | MP.OP    | MP.FP-MP.OP-crop    | Crops for use in industrial production  | N(org)                                      | 34.2                           |
| MP.NC  | MP.OP    | MP.NC-MP.OP-prod    | Precursors and chemicals for the production of consumer goods                           | N(org)                                      | 1356.0                         |
| FS.FO  | MP.OP    | FS.FO-MP.OP-wood    | Wood for material use   | N(org)                                      | 27.2                           |
| WS.SW  | MP.OP    | WS.SW-MP.OP-waste   | Material recycling of waste materials   | N(org)                                      | 349.2                          |
| RW   | MP.OP    | RW-MP.OP-prod       | Import of consumer goods containing nitrogen  | N(org)                                      | 311.4                          |
| MP.OP  | AT       | MP.OP-AT-gasEm      | NO <sub>x</sub> and N <sub>2</sub> O emissions from Other producing industry            | NO <sub>x</sub> ,<br>N <sub>2</sub> O       | 7.7<br>0.9                     |
| MP.OP  | AT       | MP.OP-AT-gasEm      | NH <sub>3</sub> emission from Other producing industry                                  | NH <sub>3</sub>                             | 4.3                            |
| MP.OP  | HS.HB    | MP.OP-HS.HB-prod    | Use of consumer goods containing nitrogen   | N(org)                                      | 165.8                          |
| MP.OP  | WS.SW    | MP.OP-WS.SW-waste   | Waste from Other producing industry   | N(org)                                      | 48.4                           |
| MP.OP  | WS.WW    | MP.OP-WS.WW-sewage  | Wastewater from Other producing industry  | N(org)                                      | 21.5                           |
| MP.OP  | RW       | MP.OP-RW-prod       | Export of consumer goods containing nitrogen  | N(org)                                      | 308.9                          |

<sup>a</sup> On "SOURCE" see Section 5.5 – allocated to the Pool(out) AT in the STAN-Diagram (Chapter 12).

<sup>b</sup> Including synthesis of calcium cyanamide.

## 5.5 Balance and comments for the “Materials and Products in Industry” (MP) pool

Materials and Products in Industry is by far the largest pool for reactive nitrogen (Tab. 5-10), above all because of the “Nitrogen Chemistry” sub-pool.

Table 5-10: Total inflows and outflows for each sub-pool and for the “Materials and Products in Industry” pool (without internal N-flows), annual mean for 2010 - 2014.

| Sub-Pool  | Inflow<br>kt N a <sup>-1</sup> | Outflow<br>kt N a <sup>-1</sup> | Difference<br>kt N a <sup>-1</sup> |
|---|--------------------------------|---------------------------------|------------------------------------|
| Food and Feed Processing  | 2568.2                         | -2684.2                         | - 116.0                            |
| Nitrogen chemistry  | 4989.3                         | -4989.3                         | 0                                  |
| Other Producing Industry  | 2077.9                         | -557.5                          | 1520.4                             |
| <b>Total “Materials and products in Industry” pool,<br/>without N-flows between sub-pools</b> | <b>8244.9</b>                  | <b>-6840.5</b>                  | <b>1404.4</b>                      |

For sub-pool “Food and Feed Processing”, the inflows and outflows of nitrogen are nearly balanced. This indicates that the statistical data, the material flows, and the underlying assumptions about the N-contents in the products correspond quite well to the actual situation.

The production and the import of nitrogenous chemicals introduces the largest N<sub>r</sub>-quantities. Domestic sales and exports of nitrogen fertilisers for agriculture account to the largest share of this. Apart from fertiliser, however, the calculation of the N-flows related to the production of nitrogenous chemicals (as precursors or finished goods) and consumer goods (for sales to consumers) involve a very high level of uncertainty. For the sub-pool “Nitrogen Chemistry”, there is a discrepancy between inflow and outflow totalling ~1500 kt N a<sup>-1</sup>. A large part of this is accounted for by the difference of ~1200 kt N a<sup>-1</sup> between the 1356 kt N a<sup>-1</sup> in the chemical precursors and products used to make consumer goods (MP.NC-MP.OP-prod) on the one hand and the 166 kt N a<sup>-1</sup> in the consumer goods for sales to consumers (MP.OP-HS.MW-prod) on the other. The uncertainty can be attributed to two causes: Firstly, the Production Survey (DESTATIS 2017), with the double counting and the many undisclosed values, is obviously rather unsuitable for registering and distinguishing between the goods flows for further processing and those for final consumption (cf. Sections 5.2.2 and 5.3). In addition, the nitrogen contents for many products or commodities are unknown, so that the values used in the calculation are only placeholders. It is also possible that high return flow of 350 kt N a<sup>-1</sup> into industrial production due to the recycling of waste materials contributes to the above-mentioned discrepancy, although this quantity is also very uncertain.

In the preceding comments and in Tab. 5-10, the entire difference between inflow and outflow is attributed to the sub-pool “Other Producing Industry”. This is based on the premise that, with the exception of fertiliser, no products of Nitrogen chemistry leave the pool when they are sold to the end consumers, but that the chemical products are transferred in full to further processing to produce end products in the sub-pool “Other Producing Industry”. In the overall reviews, the results for the sub-pools “Nitrogen Chemistry” and “Other Producing Industry” should be interpreted with considerable caution.

In Tab. 5-1 and Tab. 5-9, “SOURCE” is included as Pool(ex) for the N-flow with NH<sub>3</sub> synthesis. This term has been introduced because the National Nitrogen Budget (ECE 2013) does not make any provision for N<sub>r</sub> being generated within a pool (cf. Section 4.4). In the STAN diagram (Chapter 12), the “Atmosphere” pool is the Pool(ex) for this flow.

## **5.6 Uncertainty assessment for the N-flows of “Materials and Products in Industry” (MP) pool**

Tab. 5-11 shows the uncertainties in the calculation of the N-flows for the “Materials and Products in Industry” pool.

Table 5-11: Uncertainties in the calculation of main N-flows for “Materials and products in Industry” pool.

| Flow code  | Description  | N-species | Uncertainty Quantity structure                        | Uncertainty Coefficients | Level <sup>a</sup> |
|--|--|-----------|---|--------------------------|--------------------|
| <b>Sub-Pool “Food and Feed Processing” (MP.FP)</b> |  |           |   |                          |                    |
| EF.EC-MP.FP-prod                                   | Residues for the production of fuels from agricultural products              | N(org)    | See Tab. 4-8  |                          | 1                  |
| AG.AH-MP.FP-animProd                               | Animal market products   | N(org)    | See Tab. 7-7  |                          | 1                  |
| AG.SM-MP.FP-crop                                   | Vegetable products   | N(org)    | See Tab. 7-7  |                          | 1                  |
| RW-MP.FP-prod                                      | Imports of food and feed   | N(org)    | Low; some commodity groups only aggregated            | Very low                 | 2                  |
| MP.FP-EF.EC-fuel                                   | Agricultural products to produce fuels                                       | N(org)    | Low; crop areas: statistics, Yields: mean for Germany | Very low                 | 2                  |
| MP.FP-MP.OP-crop                                   | Crops for use in industrial production                                       | N(org)    | Low; Statistics: trade association                    | Low                      | 2                  |
| MP.FP-HS.HB-food                                   | Foodstuffs   | N(org)    | Low; some commodity groups only aggregated            | Low                      | 2                  |
| MP.FP-HS.HB-feed                                   | Feed for pets (dogs and cats)  | N(org)    | Medium; Numbers and consumption are estimated         | Medium                   | 3                  |
| MP.FP-AG.AH-feed                                   | Feed for agricultural livestock (domestic production)                        | N(org)    | See Tab. 7-7  |                          | 1                  |
| MP.FP-AG.SM-orgFert                                | Bone meal – Use as organic fertiliser  | N(org)    | Low; Statistics: trade association                    | Low                      | 2                  |
| MP.FP-AG.SM-seed                                   | Production of agricultural Seed and planting stock (not produced internally) | N(org)    | See Tab. 7-7  |                          | 1                  |
| MP.FP-AG.BP-cosub                                  | Biogas co-substrate (non-agricultural biomass)                               | N(org)    | See Tab. 7-7  |                          | 2                  |

| Flow code                                    | Description   | N-species                             | Uncertainty Quantity structure                                  | Uncertainty Coefficients                                | Level <sup>a</sup> |
|--|---|---------------------------------------|---|---|--------------------|
| MP.FP-WS.SW-fuel                             | Bone meal - Thermal recycling   | N(org)                                | Low; Statistics: trade association                              | Low   | 2                  |
| MP.FP-WS.WW-sewage                           | Wastewater from Food and Feed Processing                                  | N(org)                                | See Tab. 9-8  |   | 4                  |
| MP.FP-RW-prod                                | Export of foodstuffs and feed   | N(org)                                | Low; some commodity groups only aggregated                      | Very low  | 2                  |
| <b>Sub-Pool "Nitrogen Chemistry" (MP.NC)</b> |   |                                       |   |   |                    |
| SOURCE-MP.NC-NH3                             | Ammonia synthesis (Haber-Bosch process) <sup>b</sup>                      | NH3                                   | Very low  | Statistics already in t N)                              | 1                  |
| EF.EC-MP.NC-fuel                             | Crude oil and refinery products for processing in the chemical industry   | N(org)                                | Medium (see Section 4.1.1)                                      | Medium  |                    |
| RW-MP.NC-prod                                | Import of products of Nitrogen chemistry                                  | NH3, NO3<br>N(org)                    | Medium; some commodity groups highly aggregated                 | Medium; average N-contents for product groups estimated | 3                  |
| MP.NC-AT-gasEm                               | NO <sub>x</sub> and N <sub>2</sub> O emissions from the chemical industry | NO <sub>x</sub> ,<br>N <sub>2</sub> O | See Tab. 3-11   |   | 2 / 4              |
| MP.NC-AT-gasEm                               | NH <sub>3</sub> emission from the chemical industry                       | NH3                                   | See Tab. 3-11   |   | 3                  |
| MP.NC-EF.EC-prod                             | NH <sub>3</sub> for denoxing flue gases                                   | NH3                                   | Medium; Expert estimate   | Very low  | 3                  |
| MP.NC-MP.OP-prod                             | Production of chemicals and products(except mineral fertilisers)          | NH3, NO3<br>N(org)                    | High; can only be estimated as a difference (see Section 5.2.3) |   | 4                  |
| MP.NC-HS.MW-minFert                          | N-Mineral fertiliser for use in kitchen gardens                           | NH3, NO3<br>N(org)                    | Medium; estimates by experts                                    | Statistics already in t N                               | 3                  |
| MP.NC-AG.SM-minFert                          | N-Mineral fertiliser for use in agriculture                               | NH3, NO3<br>N(org)                    | Very low (see DESTATIS Quality report)                          | Statistics already in t N                               | 1                  |
| MP.NC-WS.WW-sewage                           | Wastewater from Nitrogen chemistry  | N(org)                                | See Tab. 9-8  |   | 4                  |



| Flow code  | Description  | N-species                                   | Uncertainty Quantity structure                                  | Uncertainty Coefficients                                | Level <sup>a</sup> |
|--|--|---|---|---|--------------------|
| MP.NC-RW-prod                                      | Export of products of Nitrogen chemistry                                     | NH <sub>3</sub> , NO <sub>3</sub><br>N(org) | Medium; some commodity groups highly aggregated                 | Medium; average N-contents for product groups estimated | 3                  |
| <b>Sub-Pool “Other Producing Industry” (MP.OP)</b> |  |   |   |   |                    |
| MP.FP-MP.OP-crop                                   | Crops for use in industrial production                                       | N(org)                                      | Low; Statistics: trade association                              | Low   | 2                  |
| MP.NC-MP.OP-prod                                   | Chemicals and products for the production of consumer goods                  | N(org)                                      | High; can only be estimated as a difference (see Section 5.2.3) |   | 4                  |
| FS.FO-MP.OP-wood                                   | Wood for material use  | N(org)                                      | see Tab. 8-9  |   | 2                  |
| WS.SW-MP.OP-waste                                  | Recycling of waste materials   | N(org)                                      | Medium to high (see Tab. 9-11)                                  | High (see Tab. 9-11)                                    | 4                  |
| RW-MP.OP-prod                                      | Import of nitrogenous products (consumer goods)                              | N(org)                                      | High; Quantities for some groups could not be determined        | High; average N-contents estimated for groups           | 4                  |
| MP.OP-AT-gasEm                                     | NO <sub>x</sub> and N <sub>2</sub> O emissions from Other producing industry | NO <sub>x</sub> ,<br>N <sub>2</sub> O       | see Tab. 3-11   |   | 2 / 4              |
| MP.OP-AT-gasEm                                     | NH <sub>3</sub> emissions from Other producing industry                      | NH <sub>3</sub>                             | see Tab. 3-11   |   | 3                  |
| MP.OP-HS.HB-prod                                   | Production of (nitrogenous) consumer goods                                   | N(org)                                      | High; Quantities for some groups could not be determined        | High; average N-contents estimated for groups           | 4                  |
| MP.OP-WS.SW-waste                                  | Waste from Other producing industry  | N(org)                                      | Medium to high (s. Tab. 9-11)                                   | High (s. Tab. 9-11)                                     | 4                  |
| MP.OP-WS.WW-sewage                                 | Wastewater from Other producing industry                                     | N(org)                                      | see Tab. 9-8  |   | 4                  |
| MP.OP-RW-prod                                      | Export of nitrogenous products (consumer goods)                              | N(org)                                      | High; Quantities for some groups could not be determined        | High; average N-contents estimated for groups           | 4                  |

<sup>a</sup> Level of uncertainty in accordance with Tab. 2-3.

## 6 Humans and Settlements (HS)

The “Humans and Settlement” pool describes the N-flows that are associated with nutrition, dwellings, and housing. It also includes the consumption of foods and consumer goods, keeping pets, and the N-flows related to urban areas. In contrast to NNB Annex 6 (ECE 2013) we only introduce two sub-pools.

- ▶ Human Body (including pets) (HS.HB)
- ▶ Material World (HS.MW).

A separate sub-pool was not introduced for pets, since it only involves a single N-flow. Tab. 6-1 gives an overview of the relevant nitrogen flows.

Table 6-1: Incoming and outgoing N-flows of the sub-pools in the “Humans and Settlements” pool<sup>a</sup>.

| Pool(ex)  | Pool(in) | Flow code           | Description   | N-species        | Chapter    |
|---|----------|---------------------|---|------------------|------------|
| <b>Sub-Pool “Human Body (and pets)” (HS.HB)<sup>a</sup></b> |          |                     |   |                  |            |
| MP.FP   | HS.HB    | MP.FPHS.HB-food     | Food for humans   | N(org)           | 5.1.1      |
| MP.FP   | HS.HB    | MP.FP-HS.HB-feed    | Feed for pets (dogs and cats)   | N(org)           | 5.1.2      |
| HY.GW   | HS.HB    | HY.GW-HS.HB-abstr   | NO <sub>3</sub> <sup>-</sup> removal with the abstraction of groundwater for drinking water | NO3              | 10.1.2     |
| HS.HB   | AT       | HS.HB-AT-gasEm      | Gaseous emissions of NH <sub>3</sub> by humans  | NH3              | 6.1        |
| HS.HB   | WS.SW    | HS.HB-WS.SW-waste   | Domestic waste (food waste)   | N(org)           | 9.1.1      |
| HS.HB   | WS.WW    | HS.HB-WS.WW-sewage  | Domestic sewage (excrements)  | N(org)           | 9.2.1      |
| <b>Sub-Pool “Material World” (HS.MW)</b>                    |          |                     |   |                  |            |
| AT  | HS.MW    | AT-HS.MW-atmDep     | Atmospheric N-deposition on settlement areas  | NHy, NOx         | 3.4        |
| MP.NC   | HS.MW    | MP.NC-HS.MW-minFert | Mineral fertiliser for use in kitchen gardens   | NO3, NH3, N(org) | 5.2.2      |
| MP.OP   | HS.MW    | MP.OP-HS.MW-prod    | Consumption of consumer goods   | N(org)           | 5.3<br>6.2 |
| FS.FO   | HS.MW    | FS.FO-HS.MW-wood    | Wood for energetic use - private households   | N(org)           | 8.1.5      |
| WS.WW   | HS.MW    | WS.WW-HS.MW-sludge  | Sludge for use in landscaping measures  | N(org)           | 9.2.2      |
| HS.MW   | WS.SW    | HS.MW-WS.SW-waste   | Consumer goods-Waste from settlement areas  | N(org)           | 9.1.1      |
| HS.MW   | WS.WW    | HS.MW-WS.WW-sewage  | Wastewater from settlement areas (sealed areas)   | N(org)           | 9.2.1      |
| HS.MW   | HY.GW    | HS.MW-HY.GW-leach   | Nitrate leaching from settlement areas  | NO3              | 10.1.1     |

<sup>a</sup> NO<sub>x</sub> and N<sub>2</sub>O emissions from settlement areas are negligible or are not reported in the National Inventory Report (NIR, UBA 2016a).

If feed for pets is included in the sub-pool “Human Body” then the sub-pool “Organic World” in NNB Annex 6 (ECE 2013), via which food and feed are allocated to the “Human Body” and to “Pets”, is also superfluous.

## 6.1 Sub-pool “Human Body” (HS.HB)

The sub-pool “Human Body” covers the use of food for humans and feed for pets. Quantities of self-grown food (kitchen gardens) are negligible and are not included. The outflow from the sub-pool is mainly in the form of excrement in the sewerage system (wastewater treatment plants, mixed-water outflows) or directly into surface waters (for households not connected to a central wastewater treatment plant). N-accumulation in human and animal bodies during the growth phase and the fate of the nitrogen after life are negligible and are not included.

NNB Annex 6 (ECE 2013) also takes into account the atmospheric emissions of ammonia with sweat and exhaled breath by humans. According to Sutton et al. (2000; cited in NNB Annex 6, Eq. 0.18) the gaseous NH<sub>3</sub> emissions are 17 g N per person and year.

$$\text{NH}_3 \text{ atm. emissions: } 0.017 \text{ kg NH}_3\text{-N a}^{-1} \times 80.91 \text{ million} = 1.4 \text{ kt N a}^{-1}.$$

As a simplification, extra terms for babies and young infants are not included.

## 6.2 Sub-pool “Material World” (HS.MW)

The sub-pool “Material World” includes nitrogenous products (excluding foodstuffs) that are used in private households. According to NNB (ECE 2013) this includes furniture, textiles and clothing, packing material, wood and cellulose products, and tobacco (see commodities in Tab. 5-8).

The production or the sale of consumer goods are reported in the Production Survey (DESTATIS 2017a, Tab. 42131-0003); the problems involved with determining the quantities of goods and the relevant N-flow are outlined in Section 5.3.

Plastics containing nitrogen are also included in consumer electronics products, vehicles, domestic appliances, etc., and in building materials (e.g. insulation). However, for these product groups no data is available about the quantities involved (by weight), not is it possible to make even remotely realistic assumptions about the N-contents.

This sub-pool also includes the N-flows related to atmospheric deposition of NH<sub>y</sub> and NO<sub>x</sub> on settlement areas, nitrate leaching from settlement areas, and the agricultural use of sludge (re-cultivation of excavations, landfill sites, etc.). The NNB system (ECE 2013) does not offer any other sub-pool for these nitrogen inflows and outflows.

### 6.3 Summary of N-flows for “Humans and Settlements” (HS) pool

Tab. 6-2 shows a summary of the N-flows for the “Humans and Settlements” pool.

Table 6-2: Incoming and outgoing N-flows for sub-pools in the “Humans and Settlements” pool, annual mean for 2010 – 2014<sup>a</sup>.

| Pool(ex)  | Pool(in) | Flow code           | Description   | N-species          | N-flow<br>kt N a <sup>-1</sup> |
|---|----------|---------------------|---|--------------------|--------------------------------|
| <b>Sub-Pool “Human Body (and pets)” (HS.HB)</b> |          |                     |   |                    |                                |
| MP.FP   | HS.HB    | MP.FP-HS.HB-food    | Food for human consumption  | N(org)             | 599.4                          |
| MP.FP   | HS.HB    | MP.FP-HS.HB-feed    | Feed for pets (dogs and cats)   | N(org)             | 68.0                           |
| HY.GW   | HS.HB    | HY.GW-HS.HB-abstr   | NO <sub>3</sub> <sup>-</sup> in groundwater abstracted for drinking water | NO3                | 15.4                           |
| HS.HB   | AT       | HS.HB-AT-gasEm      | Gaseous emissions of NH <sub>3</sub> by humans                            | NH3                | 1.4                            |
| HS.HB   | WS.SW    | HS.HB-WS.SW-waste   | Waste from households (food waste)  | N(org)             | 127.9                          |
| HS.HB   | WS.WW    | HS.HB-WS.WW-sewage  | Sewage from households  | N(org)             | 350.0                          |
| <b>Sub-Pool “Material World” (HS.MW)</b>        |          |                     |   |                    |                                |
| AT  | HS.MW    | AT-HS.MW-atmDep     | Atmospheric N-deposition on settlement areas                              | NHy<br>NOx         | 40.0<br>19.5                   |
| MP.NC   | HS.MW    | MP.NC-HS.MW-minFert | Mineral fertiliser for use in kitchen gardens                             | NO3, NH3<br>N(org) | 45.0                           |
| MP.OP   | HS.MW    | MP.OP-HS.MW-prod    | Consumption of consumer goods   | N(org)             | 165.8                          |
| WS.WW   | HS.MW    | WS.WW-HS.MW-sludge  | Sludge for use in landscaping measures                                    | N(org)             | 31.2                           |
| HS.MW   | WS.SW    | HS.MW-WS.SW-waste   | Waste from consumer goods   | N(org)             | 45.9                           |
| HS.MW   | WS.WW    | HS.MW-WS.WW-sewage  | Wastewater from settlement areas (sealed areas)                           | N(org)             | 30.0                           |
| HS.MW   | HY.GW    | HS.MW-HY.GW-leach   | Nitrate leaching from settlements and the transport infrastructure        | NO3                | 36.0                           |

<sup>a</sup> Note: NO<sub>x</sub> and N<sub>2</sub>O emissions from settlements are negligible or are not reported in the National Inventory Report (NIR, UBA 2016a).

## 6.4 Balance and comments for the “Humans and Settlements” (HS) pool

Tab. 6-3 shows the aggregated inflows and outflows for the “Humans and Settlements” pool. There is a considerable difference of 395 kt N a<sup>-1</sup>, which represents some 40 % of the nitrogen inflow. This difference can be attributed to considerable uncertainties in many N-flows. This relates to the use of the Production Survey and the discrepancy between N-flow regarding nitrogenous products into the consumer goods industry (MP.NC-MP.OP-prod) and then the quantities of consumer goods produced for sale to end consumers (MP.OP-HS.MW-prod). The comments in Section 5.6 also apply here. Furthermore, the N-contents in sewage from households and run-off from sealed areas are only estimated. Finally the N-contents of (only) 46 kt N a<sup>-1</sup> in waste commodities, derived from waste statistics, is in contrast with the N-inflow of 166 kt N a<sup>-1</sup> for the consumption of commodities. Since no other outflow comes into question for consumer goods apart from Waste, these two quantities ought to be more or less equal (apart from slight changes in stock levels). If the waste quantity from consumer goods were set at 166 kt N a<sup>-1</sup>, then the total waste outflow (food and consumer goods) would increase to 294 kt N a<sup>-1</sup> and the difference for the “Humans and Settlements” pool would be reduced to 274 kt N a<sup>-1</sup>.

Table 6-3: Balance for nitrogen inflows and outflows <sup>a</sup> (excluding agricultural products) for the “Humans and Settlements” pool, annual mean for 2010 - 2014.

| Inflow (N <sub>r</sub> -sources)   | kt N a <sup>-1</sup> | N <sub>r</sub> outflows <sup>a</sup>               |                     |
|--|----------------------|--|---------------------|
|  |                      |  | t N a <sup>-1</sup> |
| Atmospheric depositions  | 59.5                 | Waste  | - 173.8             |
| Food and feed  | 667.4                | Wastewater (from households and from sealed areas) | - 379.9             |
| Consumption of commodities   | 165.8                | Nitrate leaching (from settlements)                | - 36.0              |
| Use of mineral fertiliser, wood and sludge in settlements                          | 76.2                 |  |                     |
| NO <sub>3</sub> <sup>-</sup> in groundwater abstracted for drinking water supplies | 15.4                 |  |                     |
| <b>Total inflows</b>   | <b>984.3</b>         | <b>Total outflows</b>                              | <b>- 589.7</b>      |
| <b>Difference: 394.6</b>   |                      |  |                     |

<sup>a</sup> Gaseous NH<sub>3</sub> emissions by humans not included.

Imports and exports of food and commodities have already been accounted for in the “Materials and Products in Industry” pool, and there are no further trans-boundary material-flows into or out of the private sector.

The “Material World” sub-pool also includes N-flows into and from settlement areas. These include NH<sub>y</sub> and NO<sub>x</sub> depositions, nitrate leaching, and the use of sludge for landscaping and re-cultivation measures.

## 6.5 Uncertainty assessment for the N-flows of “Humans and Settlements” (HS) pool

Tab. 6-4 shows the uncertainties in the calculation of the N-flows for the “Humans and Settlements” pool.

Table 6-4: Uncertainties in the calculation of key N-flows for “Humans and Settlements” pool.

| Flow code                                       | Description   | N-species        | Uncertainty Quantity structure | Uncertainty coefficients                                     | Level <sup>a</sup> |
|---|---|------------------|--------------------------------|--|--------------------|
| <b>Sub-Pool “Human Body (and pets)” (HS.HB)</b> |   |                  |                                |  |                    |
| MP.FP-HS.HB-food                                | Food for humans   | N(org)           | See Tab. 5-11                  |  | 2                  |
| MP.FP-HS.HB-feed                                | Feed for pets (dogs and cats)   | N(org)           | See Tab. 5-11                  |  | 3                  |
| HY.GW-HS.HB-abstr                               | NO <sub>3</sub> <sup>-</sup> in groundwater abstracted for drinking water | NO3              | Low                            | Medium, NO <sub>3</sub> <sup>-</sup> concentration estimated | 3                  |
| HS.HB-WS.SW-waste                               | Domestic waste (food waste)   | N(org)           | High, see Tab. 5-11            |  | 4                  |
| HS.HB-WS.WW-sewage                              | Sewage from households (excrements)                                       | N(org)           | See Tab. 9-8                   |  | 3                  |
| <b>Sub-Pool “Material World” (HS.MW)</b>        |   |                  |                                |  |                    |
| AT-HS.MW-atmDep                                 | Atmospheric N-deposition on settlement areas                              | NHy, NOx         | See Tab. 3-11                  |  | 3                  |
| MP.NC-HS.MW-minFert                             | Mineral fertiliser for use in kitchen gardens                             | NO3, NH3, N(org) | See Tab. 5-11                  |  | 3                  |
| MP.OP-HS.HB-prod                                | Consumption of consumer goods   | N(org)           | See Tab. 5-11                  |  | 4                  |
| WS.WW-HS.MW-sludge                              | Sludge for use in landscaping measures                                    | N(org)           | See Tab. 9-8                   |  | 2                  |
| FS.FO-HS.MW-wood                                | Wood for energetic use - private households                               | N(org)           | See Tab. 8-9                   |  | 2                  |
| HS.MW-WS.SW-waste                               | Consumer goods-Waste from settlements                                     | N(org)           | High, see Tab. 5-11            |  | 4                  |
| HS.MW-WS.WW-sewage                              | Wastewater from settlement areas (sealed areas)                           | N(org)           | See Tab. 9-8                   |  | 4                  |
| HS.MW-HY.GW-leach                               | Nitrate leaching from Settlements and the transport infrastructure        | N(org)           | See Tab. 10-8                  |  | 4                  |

<sup>a</sup> Level of uncertainty in accordance with Tab. 2-3.

## 7 Agriculture (AG)

The “Agriculture” pool occupies a key position in the overall nitrogen cycle. Nitrogen balances have been drawn up regularly for agriculture in Germany for many years, and these include three components: (i) Soil management on agricultural areas, (ii) Agricultural livestock, and (iii) Generation of biogas from agricultural biomass. These three sectors are linked with one another through the exchanges of agricultural products (fodder, manure, biogas substrates, etc.). In line with this structure, and in contrast to NNB Annex 3 and Annex 5 (ECE 2016), three corresponding sub-pools for N-flows in the “Agriculture” pool:

- ▶ Animal Husbandry (AG.AH)
- ▶ Soil Management (AG.SM)
- ▶ Biogas production (AG.BP).

The management of manure (NH<sub>3</sub> losses during storage, handling and application) from animal husbandry and biogas production is not included as a separate sub-pool (which is the case in NNB Annex 3), but is integrated in the calculation of N-flows in the sub-pools “Animal Husbandry” and “Soil Management”. This corresponds to the approach usually adopted in the nitrogen balances for agriculture in Germany.

A further difference relates to biogas plants. In NNB Annex 5, these are included in the Waste sector on the grounds that biogas plants were mainly used for the treatment or disposal of organic residues. However, biogas plants in Germany benefit under the Renewable Energy Sources Act (EEG) and are installed in the majority of cases for energetic purposes. These are as a rule operated either directly by farms, or are closely integrated in material flows from and to the agricultural sector. The large majority of the biomass for fermentation is from agricultural operations, and the digestate is then used in agriculture. As a result, the data about the use of substrates in biogas plants are mainly found in agricultural statistics. Consequently, “Biogas Production” is included as a sub-pool of “Agriculture” pool in the N-flow scheme for Germany. Tab. 7-1 gives an overview of the nitrogen flows.

The calculation of nitrogen balances for agriculture in Germany is well-established. Reference sources are the N-Balances calculated in accordance with the methodology of Bach et al. (2011), Häußermann et al. (2019), and Mielenz and Diesler (2018) by the Julius-Kühn Institute (JKI, Braunschweig) in collaboration with the Institute for Resource Management and Landscape Ecology, University of Giessen, as published annually by BMEL. This N-flow scheme for Germany therefore draws as far as possible on this data. The BMEL nitrogen budget for agriculture for each year consists of four files: (1) Data, (2) Coefficients, (3) Calculations, and (4) Balances. Only the latter are available online ([www.bmel-statistik.de/landwirtschaft/statistischer-monatsbericht-des-bmel-kapitel-a-landwirtschaft/](http://www.bmel-statistik.de/landwirtschaft/statistischer-monatsbericht-des-bmel-kapitel-a-landwirtschaft/), download of the tables MBT-0111130-0000.xls to MBT0111290-0000.xls). In part, we drew in the following on data from the files “Data” and “Calculations”, where the quantities are already presented in tonnes N per year, with the statistical sources for the natural quantities and the N-contents. The files can be provided on request by the authors or by JKI.



Table 7-1: Incoming and outgoing N-flows of the sub-pools in the “Agriculture” pool.

| Pool(ex)                                   | Pool(in) | Flow code            | Description  | N-species                           | Chapter |
|--|----------|----------------------|--|-------------------------------------|---------|
| <b>Sub-Pool “Animal Husbandry” (AG.AH)</b> |          |                      |  |                                     |         |
| MP.FP                                      | AG.AH    | MP.FP-AG.AH-feed     | Feed from industrial production (domestic production and imports)                                  | N(org)                              | 7.1.1   |
| AG.SM                                      | AG.AH    | AG.SM-AG.AH-crop     | Feed from internal production – Soil Management  | N(org)                              | 7.2.1   |
| AG.AH                                      | AT       | AG.AH-AT-gasEm       | NO <sub>x</sub> and N <sub>2</sub> O emissions from animal husbandry (including manure management) | NO <sub>x</sub><br>N <sub>2</sub> O | 3.2.1   |
| AG.AH                                      | AT       | AG.AH-AT-gasEm       | NH <sub>3</sub> emission from housing and storage of manure  | NH <sub>3</sub>                     | 3.3     |
| AG.AH                                      | MP.FP    | AG.AH-MP.FP-animProd | Animal market products   | N(org)                              | 7.1.1   |
| AG.AH                                      | MP.FP    | AG.AH-MP.FP-fish     | Produce of aquaculture and inland fisheries  | N(org)                              | 7.1.2   |
| AG.AH                                      | AG.SM    | AG.AH-AG.SM-manure   | Animal excretions for use as manure, after deduction of housing and storage losses                 | N(tot)                              | 7.1.1   |
| AG.AH                                      | AG.BP    | AG.AH-AG.BP-manure   | Animal excretions for use as digestion substrate, after deduction of housing and storage losses    | N(tot)                              | 7.3     |
| <b>Sub-Pool “Soil Management” (AG.SM)</b>  |          |                      |  |                                     |         |
| AT   | AG.SM    | AT-AG.SM-atmDep      | Atmospheric N-deposition on agricultural areas   | NH <sub>y</sub><br>NO <sub>x</sub>  | 3.4     |
| AT   | AG.SM    | AT-AG.SM-Nfix        | Biological N-fixing in utilised agricultural areas   | N(org)                              | 7.2.1   |
| MP.FP                                      | AG.SM    | MP.FP-AG.SM-orgFert  | Application of organic fertiliser - Bone meal  | N(org)                              | 5.1.4   |
| MP.FP                                      | AG.SM    | MP.FP-AG.SM-seed     | Input with seed and planting stock (not produced internally)                                       | N(org)                              | 7.2.1   |
| MP.NC                                      | AG.SM    | MP.NC-AG.SM-minFert  | Mineral fertiliser for use in Agriculture  | N(tot)                              | 7.2.1   |
| AG.AH                                      | AG.SM    | AG.AH-AG.SM-manure   | Manure from internal production in Soil Management, after deduction of housing and storage losses  | N(tot)                              | 7.1.1   |
| AG.BP                                      | AG.SM    | AG.BP-AG.SM-digest   | Digestate as manure  | N(tot)                              | 7.3     |
| HY.GW                                      | AG.SM    | HY.GW-AG.SM-irrig    | NO <sub>3</sub> <sup>-</sup> input with irrigation water   | NO <sub>3</sub>                     | 7.2.2   |
| WS.SW                                      | AG.SM    | WS.SW-AG.SM-compost  | Application of organic fertiliser – compost (from settlement waste)                                | N(org)                              | 7.2.1   |
| WS.WW                                      | AG.SM    | WS.WW-AG.SM-sludge   | Sludge for use in agriculture  | N(org)                              | 7.2.1   |
| RW   | AG.SM    | RW-AG.SM-manure      | Import of manure from animal husbandry   | N(tot)                              | 7.2.1   |

| Pool(ex) | Pool(in) | Flow code          | Description  | N-species                           | Chapter         |
|----------|----------|--------------------|--|-------------------------------------|-----------------|
| AG.SM    | AT       | AG.SM-AT-gasEm     | NO <sub>x</sub> and N <sub>2</sub> O emissions from the application of mineral and organic fertilisers and farming organic soils | NO <sub>x</sub><br>N <sub>2</sub> O | 3.2.1           |
| AG.SM    | AT       | AG.SM-AT-gasEm     | NH <sub>3</sub> emissions from the application of mineral and organic fertilisers and farming organic soils                      | NH <sub>3</sub>                     | 3.3             |
| AG.SM    | AT       | AG.SM-AT-N2        | Denitrification from the farming of agriculturally used mineral soils and organic soils  | N <sub>2</sub>                      | 7.2.3           |
| AG.SM    | MP.FP    | AG.SM-MP.FP-crop   | Vegetable products   | N(org)                              | 7.2.1           |
| AG.SM    | AG.AH    | AG.SM-AG.AH-crop   | Feed from in-farm production   | N(org)                              | 7.2.1           |
| AG.SM    | AG.BP    | AG.SM-AG.BP-crop   | Plant biomass from internal production as biogas substrate   | N(org)                              | 7.2.1           |
| AG.SM    | HY.GW    | AG.SM-HY.GW-leach  | NO <sub>3</sub> <sup>-</sup> leaching from agricultural areas  | NO <sub>3</sub>                     | 7.2.4<br>10.1.1 |
| AG.SM    | HY.SW    | AG.SM-HY.SW-runoff | N-inputs from agricultural areas into surface waters due to runoff, erosion, and drainage  | NO <sub>3</sub><br>N(org)           | 7.2.4<br>10.2.1 |

**Sub-Pool “Biogas Production” (AG.BP)**

|       |       |                     |  |                                     |       |
|-------|-------|---------------------|--|-------------------------------------|-------|
| MP.FP | AG.BP | MP.FP-AG.BP-cosub   | Biogas co-substrate (non-agricultural biomass)                                   | N(org)                              | 7.3   |
| AG.AH | AG.BP | AG.AHM-AG.BP-manure | Biogas substrate from farm manure, after deduction of housing and storage losses | N(tot)                              | 7.3   |
| AG.SM | AG.BP | AG.SM-AG.BP-crop    | Biogas-substrate from farm plant biomass   | N(org)                              | 7.3   |
| AG.BP | AT    | AG.BP-AT-gasEm      | NO <sub>x</sub> and N <sub>2</sub> O emissions from biogas production            | NO <sub>x</sub><br>N <sub>2</sub> O | 3.2.1 |
| AG.BP | AT    | AG.BP-AT-gasEm      | NH <sub>3</sub> emissions from biogas production                                 | NH <sub>3</sub>                     | 3.3   |
| AG.BP | AG.SM | AG.BP-AG.SM-digest  | Digestate as manure  | N(tot)                              | 7.3   |

## 7.1 Sub-pool “Animal Husbandry” (AG.AH)

The sub-pool “Animal Husbandry” covers the keeping of agricultural livestock for the production of animal products (milk, meat, eggs, wool). Horses also form part of this sub-pool, because they are mostly held in agricultural businesses, and they are included in the statistics of the Agricultural Census.

### 7.1.1 Agricultural animal husbandry (XX.XX-AG.AH, AG.AH-XX.XX)

Nitrogen inflows in this sub-pool are in feed from in-farm production and the feed industry, and the N-outflows from animal husbandry are animal market products, the manure from animal husbandry (including slurry and liquid manure), as well as gaseous emissions of ammonia (Tab. 7-2). The figures in Tab. 7-2, except for gaseous emissions (see Sections 3.2.1 and 3.3), are taken from the German nitrogen balance of the BMEL (see introduction to Chapter 7).

Table 7-2: Incoming and outgoing N-flows for the sub-pool “Animal Husbandry” (not including inland fisheries and aquaculture), annual mean for 2010 - 2014.

| Flow code            | Source for the calculation of the N-flow<br>BMEL: Position in the N-Balance of BMEL                | N-species                           | N-flow<br>kt N a <sup>-1</sup> |
|----------------------|--|-------------------------------------|--------------------------------|
| MP.FP-AG.AH-feed     | Feed from industrial production (domestic production and imports)                                  | N(org)                              | 1102.2                         |
| AG.SM-AG.AH-crop     | Feed from internal production – Soil Management  | N(org)                              | 1009.4                         |
| AG.AH-AT-gasEm       | NO <sub>x</sub> and N <sub>2</sub> O emissions from animal husbandry (including manure management) | NO <sub>x</sub><br>N <sub>2</sub> O | n.c.<br>8.3                    |
| AG.AH-AT-gasEm       | NH <sub>3</sub> emission from housing and storage of animal excreta                                | NH <sub>3</sub>                     | 219.4                          |
| AG.AH-MP.FP-animProd | Animal products  | N(org)                              | 413.5                          |
| AG.AH-AG.SM-manure   | Manure for use as fertiliser, after deduction of housing and storage losses                        | N(tot)                              | 737.9                          |
| AG.AH-AG.BP-manure   | Manure for anaerobic digestion substrate, after deduction of housing and storage losses            | N(tot)                              | 181.0                          |

n.c.: not considered.

### 7.1.2 Aquaculture and inland fisheries (AG.AH-fish)

In the NNB system (ECE 2013), the production of fish, crustaceans, and molluscs in aquaculture businesses is included in Agriculture. Quantities produced are provided in the Annual Statistics on Food, Agriculture and Forests (BMEL 2016, Table 281), annual mean for 2010 - 2014:

Aquaculture and inland fisheries: 24,900 t round weight x 2.8 % N (ECE 2013, Annex 6, Table 12) = 0.7 kt N a<sup>-1</sup>.

## 7.2 Sub-pool “Soil Management” (AG.SM)

The sub-pool “Soil Management” covers all N-flows associated with growing crops on agricultural areas. Nitrogen inputs are primarily introduced by the application of mineral fertilisers, manure from animal husbandry and the digestate from biogas production, the biological N-fixing, and atmospheric N-deposition (Tab. 7-3). On the outflow side, is the production of crops for use as food or feed, and plant biomass as substrate for biogas production or as a resource for industrial processes, as well as emissions into the atmosphere and the hydrosphere. In Section 7.2.4 the calculation of the emissions into the hydrosphere is explained.

### 7.2.1 Soil Management (XX.XX-AG.SM, AG.SM-XX.XX)

The results for the various nitrogen inflows and outflows for the “Soil Management” sub-pool (see Tab. 7-3) are derived mainly from the BMEL nitrogen budget (see introduction to Chapter 7), details for the other N-flows can be found in Tab. 7-1 and Sections 7.2.2 to 7.2.4.

Table 7-3: N-flows of the nitrogen balance for sub-pool “Soil Management”, annual mean for 2010 - 2014.

| Flow code           | Source for the calculation of the N-flow<br>BMEL: Position in the N-Balance of BMEL  | N-species     | N-flow<br>kt N a <sup>-1</sup> |
|---------------------|--|---------------|--------------------------------|
| AT-AG.SM-atmDep     | Atmospheric N-deposition on agricultural areas   | NHy<br>NOx    | 185.2<br>90.9                  |
| AT-AG.SM-Nfix       | Biological N-fixing in utilised agricultural areas   | N(org)        | 194.6                          |
| MP.FP-AG.SM-orgFert | Application of organic fertiliser - Bone meal  | N(org)        | 12.8                           |
| MP.FP-AG.SM-seed    | Input with Seed and planting stock (not produced internally)   | N(org)        | 22.2                           |
| MP.NC-AG.SM-minFert | Mineral fertilisation for use in Agriculture   | N(tot)        | 1619.0 <sup>a</sup>            |
| AG.AH-AG.SM-manure  | Manure from internal production in Soil Management, after deduction of housing and storage losses                                      | N(tot)        | 737.9                          |
| AG.BP-AG.SM-digest  | Digestate as manure  | N(tot)        | 382.5                          |
| HY.GW-AG.SM-irrig   | NO <sub>3</sub> <sup>-</sup> introduced with irrigation water  | NO3           | 1.6                            |
| WS.SW-AG.SM-compost | Application of organic fertiliser – compost (from settlement waste)  | N(org)        | 23.4                           |
| WS.WW-AG.SM-sludge  | Application of organic fertiliser - sludge   | N(org)        | 24.9 <sup>b</sup>              |
| RW-AG.SM-manure     | Import of manure from animal husbandry   | N(tot)        | 14.3                           |
| AG.SM-AT-gasEm      | NO <sub>x</sub> and N <sub>2</sub> O emissions from the application of von mineral and organic fertiliser from organic soil management | NOx<br>N2O    | 35.3<br>56.6                   |
| AG.SM-AT-gasEm      | NH <sub>3</sub> emissions from the application of mineral and organic fertiliser and from organic soil management                      | NH3           | 336.1                          |
| AG.SM-AT-N2         | Denitrification with the farming of mineral soils and organic soils  | N2            | 233.9                          |
| AG.SM-MP.FP-crop    | Vegetable products   | N(org)        | 1134.0                         |
| AG.SM-AG.AH-crop    | Farm-generated feed  | N(org)        | 1009.4                         |
| AG.SM-AG.BP-crop    | On-farm crops as biogas-substrate  | N(org)        | 246.2                          |
| AG.SM-HY.GW-leach   | NO <sub>3</sub> <sup>-</sup> leaching from agricultural areas (root zone)  | NO3           | 757.1                          |
| AG.SM-HY.SW-runoff  | N-discharge from agricultural areas into surface waters due to runoff, erosion, and drainage   | NO3<br>N(org) | 113.7<br>8.2                   |

<sup>a</sup> Figures from the BMEL-Statistics reduced by the amount of mineral fertiliser applied outside agriculture (kitchen gardens, green spaces, sports facilities; see section 5.2.3).

<sup>b</sup> A slight difference to the statistics “Wastewater treatment – sludge” (DESTATIS 2017b).

### 7.2.2 NO<sub>3</sub><sup>-</sup> in irrigation water (HY.GW-AG.SM-irrig)

In 2009, Germany's agricultural sector used 293 million m<sup>3</sup> water for irrigation (DESTATIS 2011, Tab. 1202), more recent data are not available. Some 75 % of irrigation water was extracted from groundwater. As an estimated value for the mean nitrate contents in groundwater (and as a simplification also for irrigation water of other origins) a value of 25 mg NO<sub>3</sub><sup>-</sup> l<sup>-1</sup> was used, corresponding to 5.6 mg N l<sup>-1</sup>, which gives a N input with irrigation water of approx. 1.6 kt N a<sup>-1</sup> (in 2009).

### 7.2.3 Denitrification in soils in utilised agricultural areas (AG.SM-AT-N2)

The possible annual nitrogen-losses by denitrification in the root zone of utilised agricultural soils show extreme fluctuations. Depending on the soil type, management methods, and weather conditions, the denitrification may vary between very low (<<10 kg N ha<sup>-1</sup> a<sup>-1</sup>) up to complete nitrate degradation (>150 kg N ha<sup>-1</sup> a<sup>-1</sup>) in wet moor soils (NLfB 2015, Well et al. 2016). In the following, we use the value of 14 kg N ha<sup>-1</sup> a<sup>-1</sup> given by Well et al. (2016) for the mean N<sub>2</sub> emissions from utilised agricultural areas in Germany. The areas are based on the figures from the Agricultural Census (2010), since these are assumed to offer the best correspondence with the utilised areas with denitrification in soil (cf. Tab. 3-3).

Denitrification: 14 kg N ha<sup>-1</sup> a<sup>-1</sup> x 16,704,000 ha = 233.9 kt N a<sup>-1</sup>.

This value involves considerable uncertainty and represents a placeholder.

### 7.2.4 Discharges into the Hydrosphere (AG.SM-HY.GW-leach, AG.SM-HY.GW-runoff)

The N-discharges into the Hydrosphere are calculated as the difference between the total inflows and the other calculated outflows from the "Agriculture" pool (see Table 7-6). The application of mineral and organic fertilisers, feed (from non-agricultural sources), seed and planting stock, import of manure, biogas co-substrate, atmospheric deposition and N-fixation lead to combined total inflows of 3320.1 kt N a<sup>-1</sup>. In addition to nitrogen outflows in vegetable and animal products, there are also gaseous N<sub>r</sub> emissions (NH<sub>3</sub>, NO<sub>x</sub>), which can both be calculated quite accurately, and also the denitrification in the root zone from agricultural soils (although this is a placeholder quantity). These N-outflows (not including the hydrosphere) give an interim total of 2440.8 kt N a<sup>-1</sup> (see Table 7-6, right column), which is 879.0 kt N a<sup>-1</sup> less than the N-inflows.

Under the premise that (i) There are no further N-outflows from the "Agriculture" pool, and (ii) The N-stock in the soil does not change (cf. Section 7.5.2), this difference of 879.0 kt N a<sup>-1</sup> is interpreted as the N-flow into the hydrosphere from agricultural areas. This includes the NO<sub>3</sub><sup>-</sup> leaching from the root zone of the soil (as system boundary of the "Agriculture" pool) and the N-inflow into surface waters as a result of runoff, erosion and drainage.

A value of 121.9 kt N a<sup>-1</sup> is calculated for the N-inflow into surface waters due to runoff, erosion, and drainage from utilised agricultural areas (i.e. lateral outflows) using the MoRE model (see Section 10.2.1). This leaves a residual amount of 757.1 kt N a<sup>-1</sup> for leaching in vertical flows below the root zone as a second transport pathway into the hydrosphere from agricultural areas.

## 7.3 Sub-pool "Biogas production" (AG.BP)

Over the past two decades, a growing proportion of vegetable produce in Germany has been used in biogas plants (mainly silage maize and fodder crops), as well as some manure from animal husbandry. The digestate is then spread on agricultural areas. "Biogas Production" now represents an important new sub-pool for agriculture alongside "Soil Management" and "Animal Husbandry", and meanwhile accounts for a considerable proportion of the nitrogen flows (Tab. 7-4). The results are taken from the German nitrogen balance of BMEL (cf. introduction to Chapter 7).

Table 7-4: N-flows for the sub-pool “Biogas Production”, annual mean for 2010 - 2014.

| Flow code          | Source for the calculation of the BMEL: Position in the N-balance of BMEL | N-species        | N-flow<br>kt N a <sup>-1</sup> |
|--------------------|---|------------------|--------------------------------|
| MP.FP-AG.BP-cosub  | Biogas co-substrate (non-agricultural biomass)                            | N(org)           | 31.4                           |
| AG.HM-AG.BP-crop   | Biogas substrate from on-farm vegetable biomass                           | N(org)           | 181.0                          |
| AG.SM-AG.BP-manure | Biogas substrate from manure, minus housing and storage losses            | N(tot)           | 246.2                          |
| AG.BP-AT-gasEm     | NO <sub>x</sub> and N <sub>2</sub> O emissions from biogas production     | NO <sub>x</sub>  | 0.7                            |
|                    |   | N <sub>2</sub> O | 0.6                            |
| AG.BP-AT-gasEm     | NH <sub>3</sub> emissions from biogas production                          | NH <sub>3</sub>  | 2.5 <sup>a</sup>               |
| AG.BP-AG.SM-digest | Digestate as manure   | N(tot)           | 382.5                          |

## 7.4 Summary of N-flows for the “Agriculture” (AG) pool

Table 7-5 shows a summary of the N-flows for the “Agriculture” pool.

Table 7-5: Incoming and outgoing N-flows of the “Agriculture” sub-pools, mean for 2010 – 2014.

| Pool (ex)                                  | Pool (in) | Flow code            | Description  | N-species              | N-flow<br>kt N a <sup>-1</sup> |
|--|-----------|----------------------|--|------------------------|--------------------------------|
| <b>Sub-Pool “Animal Husbandry” (AG.AH)</b> |           |                      |  |                        |                                |
| MP.FP                                      | AG.AH     | MP.FP-AG.AH-feed     | Feed from industrial production (domestic production and imports)                                      | N(org)                 | 1102.2                         |
| AG.SM                                      | AG.AH     | AG.SM-AG.AH-crop     | Feed from internal production – Soil Management  | N(org)                 | 1009.4                         |
| AG.AH                                      | AT        | AG.AH-AT-gasEm       | NO <sub>x</sub> and N <sub>2</sub> O emissions from animal husbandry (including fertiliser management) | NO <sub>x</sub>        | n.r.                           |
|  |           |                      |  | N <sub>2</sub> O       | 8.3                            |
| AG.AH                                      | AT        | AG.AH-AT-gasEm       | NH <sub>3</sub> emissions from housing and storage of manure   | NH <sub>3</sub>        | 219.4                          |
| AG.AH                                      | MP.FP     | AG.AH-MP.FP-animProd | Animal products  | N(org)                 | 413.5                          |
| AG.AH                                      | MP.FP     | AG.AH-MP.FP-fish     | Produce of aquaculture and inland fisheries  | N(org)                 | 0.7                            |
| AG.AH                                      | AG.SM     | AG.AH-AG.SM-manure   | Animal excrement for use as manure, after deduction of housing and storage losses                      | N(tot)                 | 737.9                          |
| AG.AH                                      | AG.BP     | AG.AH-AG.BP-manure   | Animal excrement for use as digesting substrate, after deduction of housing and storage losses         | N(tot)                 | 181.0                          |
| <b>Sub-Pool “Soil Management” (AG.SM)</b>  |           |                      |  |                        |                                |
| AT   | AG.SM     | AT-AG.SM-atmDep      | Atmospheric N-deposition on agricultural areas   | NHy<br>NO <sub>x</sub> | 185.2<br>90.9                  |
| AT   | AG.SM     | AT-AG.SM-Nfix        | Biological N-fixing in utilised agricultural areas   | N(org)                 | 194.6                          |
| MP.FP                                      | AG.SM     | MP.FP-AG.SM-orgFert  | Application of organic fertiliser - Bone meal  | N(org)                 | 12.8                           |
| MP.FP                                      | AG.SM     | MP.FP-AG.SM-seed     | Input with Seed and planting stock (not produced internally)   | N(org)                 | 22.2                           |

| Pool (ex)                                   | Pool (in) | Flow code           | Description  | N-species     | N-flow kt N a <sup>-1</sup> |
|---|-----------|---------------------|--|---------------|-----------------------------|
| MP.NC                                       | AG.SM     | MP.NC-AG.SM-minFert | Mineral fertiliser for use in agriculture  | N(tot)        | 1619.0                      |
| AG.AH                                       | AG.SM     | AG.AH-AG.SM-manure  | Manure from internal production in Soil Management, after deduction of housing and storage losses                                | N(tot)        | 737.9                       |
| AG.BP                                       | AG.SM     | AG.BP-AG.SM-digest  | Digestate as manure  | N(tot)        | 382.5                       |
| HY.GW                                       | AG.SM     | HY.GW-AG.SM-irrig   | NO <sub>3</sub> <sup>-</sup> input with irrigation water   | NO3           | 1.6                         |
| WS.SW                                       | AG.SM     | WS.SW-AG.SM-compost | Application of organic fertiliser – Compost (from settlement waste)  | N(org)        | 23.4                        |
| WS.WW                                       | AG.SM     | WS.WW-AG.SM-sludge  | Sludge for use in agriculture  | N(org)        | 24.9                        |
| RW  | AG.SM     | RW-AG.SM-manure     | Imported manure from animal husbandry  | N(tot)        | 14.3                        |
| AG.SM                                       | AT        | AG.SM-AT-gasEm      | NO <sub>x</sub> and N <sub>2</sub> O emissions from the application of mineral and organic fertilisers and farming organic soils | NOx<br>N2O    | 35.3<br>56.6                |
| AG.SM                                       | AT        | AG.SM-AT-gasEm      | NH <sub>3</sub> emissions from the application of von mineral and organic fertilisers and farming organic soils                  | NH3           | 336.1                       |
| AG.SM                                       | AT        | AG.SM-AT-N2         | Denitrification with the farming of mineral soils and organic soils  | N2            | 233.9                       |
| AG.SM                                       | MP.FP     | AG.SM-MP.FP-crop    | Vegetable products   | N(org)        | 1134.0                      |
| AG.SM                                       | AG.AH     | AG.SM-AG.AH-crop    | Feed from internal production  | N(org)        | 1009.4                      |
| AG.SM                                       | AG.BP     | AG.SM-AG.BP-crop    | Vegetable biomass from internal production as biogas-substrate   | N(org)        | 246.2                       |
| AG.SM                                       | HY.GW     | AG.SM-HY.GW-leach   | NO <sub>3</sub> <sup>-</sup> leaching from agricultural areas (root zone)  | NO3           | 757.1                       |
| AG.SM                                       | HY.SW     | AG.SM-HY.SW-runoff  | N-discharge from agricultural areas into surface waters due to runoff, erosion and drainage                                      | NO3<br>N(org) | 113.7<br>8.2                |
| <b>Sub-Pool “Biogas Production” (AG.BP)</b> |           |                     |  |               |                             |
| MP.FP                                       | AG.BP     | MP.FP-AG.BP-cosub   | Biogas co-substrate (non-agricultural biomass)   | N(org)        | 31.4                        |
| AG.AH                                       | AG.BP     | AG.AHM-AG.BP-manure | Biogas substrate from manure, after deduction of housing and storage losses  | N(tot)        | 181.0                       |
| AG.SM                                       | AG.BP     | AG.SM-AG.BP-crop    | Biogas-substrate from on-farm crops vegetable biomass  | N(org)        | 246.2                       |
| AG.BP                                       | AT        | AG.BP-AT-gasEm      | NO <sub>x</sub> and N <sub>2</sub> O emissions from biogas production  | NOx<br>N2O    | 0.7<br>0.6                  |
| AG.BP                                       | AT        | AG.BP-AT-gasEm      | NH <sub>3</sub> emissions from biogas production   | NH3           | 2.5                         |
| AG.BP                                       | AG.SM     | AG.BP-AG.SM-digest  | Digestate as manure  | N(tot)        | 382.5                       |



## 7.5 Balance and comments for the “Agriculture” (AG) pool

### 7.5.1 Balance of N-flows in agriculture

“Agriculture” pool and its sub-pools “Soil Management”, “Animal Husbandry” and “Biogas Production” form the second largest pool for reactive nitrogen in Germany. Tab. 7-6 compares the nitrogen inflows and outflows.

Table 7-6: Nitrogen inflows and outflows for the “Agriculture” pool, annual mean for 2010 – 2014; *italics: N-flow calculated as a difference.*

| Inflow (N <sub>r</sub> -sources)                              | kt N a <sup>-1</sup>       | N <sub>r</sub> outflow  | kt N a <sup>-1</sup>        |
|---|----------------------------|---|-----------------------------|
| Mineral fertiliser  | 1619.0                     | Vegetable products  | -1134.0                     |
| Application of organic fertilisers <sup>a</sup>               | 60.3                       | Animal market products  | -413.5                      |
| Feed – industrial production                                  | 1102.2                     | All NH <sub>3</sub> emissions   | -558.0                      |
| Imports with seed and planting stock                          | 22.2                       | All NO <sub>x</sub> and N <sub>2</sub> O emissions  | -101.4                      |
| Import of manure  | 14.3                       | Denitrification in soils (root zone)  | -233.9                      |
| Biogas co-substrate (non-agricultural biomass)                | 31.4                       | <b>Interim total <sup>c</sup></b>   | <b>- 2440.8<sup>c</sup></b> |
| Atmospheric N-deposition (NO <sub>x</sub> , NH <sub>y</sub> ) | 276.1                      | Lateral NO <sub>3</sub> <sup>-</sup> discharge into surface waters (Runoff, Erosion and Drainage) | -121.9 <sup>d</sup>         |
| Biological N-fixing   | 194.6                      | <i>Nitrate leaching into groundwater (below the root zone) <sup>e</sup></i>                       | <i>-757.1<sup>e</sup></i>   |
| <b>Total inflows</b>  | <b>3320.1 <sup>b</sup></b> | <b>Total outflows</b>   | <b>-3320.1</b>              |
| <b>Difference: 0.0 <sup>f</sup></b>                           |                            |   |                             |

<sup>a</sup> Compost (from settlement waste), sludge, bone meal.

<sup>b</sup> Including 1.6 kt N a<sup>-1</sup> with irrigation.

<sup>c</sup> Total inflows minus total outflows, not including the N-flows into the hydrosphere.

<sup>d</sup> According to the MoRE model, see Section 10.2.1

<sup>e</sup> Calculated as 879.0 kt N-surplus minus lateral NO<sub>3</sub><sup>-</sup> discharge into surface waters (see Section 7.2.4).

<sup>f</sup> Balance is based on the premise that the total outflows correspond to the total inflows (see Section 7.2.4).

The balance for the “Agriculture” pool as a whole is based on the premise that the total outflows must correspond to the total inflows. This involves two assumptions: (i) In the “Agriculture” pool all N-flows can be registered with some accuracy – with the exception of leaching and denitrification; (ii) The N-stock in soil is constant, i.e. there is no N-flow with the fixation or release of nitrogen in or from organic substances in the soil (cf. Section 7.5.2). The spatial boundary for the “Soil Management” sub-pool is set by the root zone. As a simplification, it is assumed that the leachate in the unsaturated zone below this depth is only displaced downwards, so that the nitrate content is no longer available for plants. If a value is now introduced for denitrification (see Section 7.2.3), then the budget is balanced if the difference is equal to the calculated value for the N-flow of nitrate leaching into groundwater (see Section 7.2.4).

### 7.5.2 N-stock in soil and changes in stock

According to the results of a recent soil status survey (Jacobs et al. 2018), the N<sub>total</sub> stock (0 - 100 cm depth) in agricultural soils in Germany is 11.9 t N ha<sup>-1</sup> (standard deviation approx. ±3 t N ha<sup>-1</sup>, our estimated value). The value is weighted across mineral soils (differentiated according to arable land,

grassland and special crops) and moor soils (in six classes). For an agricultural area of 16,704 kha this corresponds to a nitrogen stock of ~200,000 kt N (0 - 100 cm depth).

The soil survey for utilised agricultural areas has been carried out for the first time, and before a second inventory period is concluded and a change in the N-stock in soils in agricultural areas can be determined directly take at least another decade. The possible changes in the N-stock can at present only be determined on the basis of the changes in C-stocks.

For mineral soils under grassland, the changes in  $C_{\text{org}}$ -stocks are not significant (and thus neither are changes in N-stocks). For mineral soils under arable farmland, Jacobs et al. (2018) modelled the development of the  $C_{\text{org}}$  in the surface layer (0 - 30 cm) for specific locations on the basis of  $C_{\text{org}}$  changes in long-term soil monitoring sites in Germany. For some 80 % of mineral soils under arable land, the development of  $C_{\text{org}}$  was estimated over a period of 10 years (it was not possible to model the C-dynamics for 20 % of the locations with black-humus sands or with a high water table; Don 2019). A mean annual reduction of  $0.21 \text{ t } C_{\text{org}} \text{ ha}^{-1} \text{ a}^{-1}$  was modelled for the mineral soils under arable cropping. Assuming a mean C:N-ratio of 11:1 in surface mineral soils, this would lead to a reduction in N-stocks of  $0.019 \text{ t N ha}^{-1} \text{ a}^{-1}$ . For ~11,200 kha mineral soils under arable farmland and similar uses this corresponds to an annual stock change of some 210 kt N  $\text{a}^{-1}$  in the mineral upper level (0 - 30 cm). Results are not available for the sub-soil (30 - 100 cm).

According to the measurements and calculations of the “Organic Soils” Project (Tiemeyer et al. 2016, cited in Jacobs et al. 2018), organic soils under arable land and grassland in Germany lose an average of  $7.5 \text{ t } C_{\text{org}} \text{ ha}^{-1} \text{ a}^{-1}$ , i.e. over 20 years such a site loses more  $C_{\text{org}}$  than the total amount that is stored in a typical mineral soil (Jacobs et al. 2018). Assuming a C:N ratio of 25:1 (as an approximate mean value for various moor soils at various depths) this would correspond to  $\sim 0.3 \text{ t N ha}^{-1} \text{ a}^{-1}$ . For some 1,000 kha organic soils under farmland (~6 % of the UAA), this corresponds to a nitrogen loss due to the reduction of the N-stock in organic soils (0 -100 cm) of approx. 300 kt N  $\text{a}^{-1}$ .

For all mineral and moor soils under farmland, the estimated change in N-stock is therefore in the order of 500 kt N  $\text{a}^{-1}$ . This is an appreciable amount in comparison with the other values in the nitrogen balance. However, in contrast to the change in N-stock in forest soils, the change in N-stocks in agricultural soils is not included as N-flow in the NNB, because the figure is only the result of model estimates, and currently involves considerable uncertainties.

### 7.5.3 Comparison with the N-balance of BMEL

The annual N-balances of BMEL (see introduction to Chapter 7) do not show separate nitrogen emissions ( $\text{NH}_3$ ,  $\text{NO}_x$ ,  $\text{NO}_3^-$ ,  $\text{N}_2$ ); the goal is to calculate reliable overall N-flows in the products in order to calculate the “N surplus”, which can then function as an indicator describing the potential loss of reactive nitrogen into the hydrosphere and atmosphere. The overall surplus according to BMEL is  $1615.6 \text{ kt N a}^{-1}$  (corresponding to  $\sim 97 \text{ kg N/ha UAA}$ ) as an annual mean for 2010 - 2014. This matches very well with the values we calculated for the N-flows. Adding together the so-called N-losses (i.e. the  $\text{N}_r$  and  $\text{N}_2$  emissions into the hydrosphere and the atmosphere), gives a value of  $1772.4 \text{ kt N a}^{-1}$  in the NNB. The difference is mainly attributable to the fact that the BMEL-Balance only considers  $\text{NO}_x$  for the atmospheric N-deposition, but not  $\text{NH}_y$  depositions. BMEL argues that a large proportion of the  $\text{NH}_y$  deposition on agricultural areas originates from agricultural  $\text{NH}_y$  emissions, i.e. it forms part of an (internal) agricultural nitrogen cycle. But according to the BMEL methodology, gaseous emissions are not included in the balance. (The reasoning is that if only the  $\text{NH}_y$  inputs are taken into consideration but not the  $\text{NH}_y$  emissions then this would result in too high a value for the N surplus). Calculating the N-surplus by analogy with the NNB, leaving out the  $\text{NH}_3$  depositions on agricultural areas ( $185.2 \text{ kt N a}^{-1}$ ) gives a surplus of  $1547.5 \text{ kt N a}^{-1}$ , which corresponds well with the BMEL-surplus of  $1615.6 \text{ kt N a}^{-1}$ . The distribution of the N-surplus between the various N-species and the inputs into the atmosphere and hydrosphere are shown in Table 13-3.

#### 7.5.4 Comments on National Nitrogen Budget Annex 3

Calculations of the nitrogen balance for the agriculture in Germany have been carried out by a number of institutions over many years for various purposes and with various regional structures. A more or less standardised methodology has been developed (cf. Bach et al. 2011, BW Stickstoff 2017) which has become established and which is continually being refined. For N-balances at the national level, the goal is to harmonise the quantity structure and the coefficients as far as possible with the reporting of the National Emissions Inventory for the agricultural sector (Rösemann et al. 2017).

The specifications of the NNB Annex 3 (ECE 2016) for determining the N-flows for the “Agriculture” pool are very comprehensive, and in our view are intended for readers with little previous relevant experience. We have preferred to adopt a more pragmatic approach, and we have mainly used the results on N-flows in agriculture from the BMEL nitrogen balance for Germany. Among other things, the sub-pools we use differ from those in Annex 3. We did not examine in detail whether the methodology of the German national N-Balance corresponds to the approach in the NNB Annex 3 (ECE 2016). Our decision was made on the basis of the following considerations:

- ▶ National nitrogen budgets are still in their early stages. Our priority is therefore the provision of an inventory of N-flows for the environmental policy discussion in Germany, rather than anticipating requirements for a putative international reporting obligation which may be introduced at some time in the future.
- ▶ In order to recognise the effects of measures and trends, the nitrogen balance for Germany should be up-dated regularly. As far as possible, use should be made of existing results from other inventories or nitrogen balances for Germany, in order to reduce the workload involved.
- ▶ If the calculation of N-flows in Agriculture on the basis of Annex 3 led to results which differed from those of the established N-Balance methods for Agriculture in Germany, this could lead to the publication of conflicting values for N-flows. This would complicate issues and could raise doubts about the reliability of the values.

#### 7.6 Uncertainty assessment for the N-flows of “Agriculture” (AG) pool

Tab. 7-7 shows the uncertainties in the calculation of the N-flows for the “Agriculture” pool.

Table 7-7: Uncertainties in the calculation of important N-flows for the “Agriculture” pool.

| Flow code                                  | Description  | N-species                           | Uncertainty Quantity structure  | Uncertainty Coefficients   | Level <sup>a</sup> |
|--|--|-------------------------------------|---|--|--------------------|
| <b>Sub-Pool “Animal Husbandry” (AG.AH)</b> |  |                                     |   |  |                    |
| MP.FP-AG.AH-feed                           | Feed from industrial production (domestic production and imports)                              | N(org)                              | Very low (see DESTATIS Quality report)                                | Very low   | 1                  |
| AG.SM-AG.AH-crop                           | Feed from internal production – Soil Management  | N(org)                              | Areas: very low<br>Crop yields: low<br>(see DESTATIS Quality reports) | Low  | 2                  |
| AG.AH-AT-gasEm                             | NO <sub>x</sub> and N <sub>2</sub> O emissions from Animal husbandry                           | NO <sub>x</sub><br>N <sub>2</sub> O | see Tab. 3-11   |  | 2 / 4              |
| AG.AH-AT-gasEm                             | NH <sub>3</sub> emission from housing and storage of animal excretions                         | NH <sub>3</sub>                     | see Tab. 3-11   |  | 3                  |
| AG.AH-MP.FP-animProd                       | Animal products  | N(org)                              | Very low (see DESTATIS Quality report)                                | Very low   |                    |
| AG.AH-MP.FP-fish                           | Produce of aquaculture and inland fisheries  | N(org)                              | Very low (see DESTATIS Quality report)                                | Very low   | 1                  |
| AG.AH-AG.SM-manure                         | Animal excrement for use as manure, minus housing and storage losses                           | N(tot)                              | Low   | Low  | 2                  |
| AG.AH-AG.BP-manure                         | Animal excrement for use as Digesting substrate, after deduction of housing and storage losses | N(tot)                              | Low   | Low  | 2                  |
| <b>Sub-Pool “Soil Management” (AG.SM)</b>  |  |                                     |   |  |                    |
| AT-AG.SM-atmDep                            | Atmospheric N-depositions on Agricultural areas  | NH <sub>y</sub><br>NO <sub>x</sub>  | see Tab. 3-11   |  | 3                  |
| AT-AG.SM-Nfix                              | Biological N-fixing in utilised agricultural areas   | N(org)                              | Areas of crops with N-fixation: Low (see DESTATIS Quality report)     | High, wide range of literature results for N-fixation in legumes | 4                  |
| MP.FP-AG.SM-orgFert                        | Application of organic fertiliser - Bone meal  | N(org)                              | Very low (complete cover according to Niemann (various years))        | Low  | 2                  |

| Flow code               | Description   | N-species                           | Uncertainty Quantity structure   | Uncertainty Coefficients   | Level <sup>a</sup> |
|-------------------------|---|-------------------------------------|--|--|--------------------|
| MP.FP-AG.SM-seed        | Input with Seed and planting stock (not produced internally)  | N(org)                              | Very low (see DESTATIS Quality report)   | Very low   | 1                  |
| MP.NC-AG.SM-minFert     | Mineral fertiliser for use in Agriculture   | N(tot)                              | Very low (see DESTATIS Quality report)   | Very low   | 1                  |
| AG.AH-AG.SM-manure      | Manure from internal production in Soil Management, after deduction of housing and storage losses                                 | N(tot)                              | Low: Manure amounts<br>Medium: NH <sub>3</sub> housing and storage losses (see Section 3.10) | Low: N-contents in manure)<br>Medium: NH <sub>3</sub> -Verlustcoefficients (see Section 3.10)  | 2 / 3              |
| AG.BP-AG.SM-digest      | Digestate as manure   | N(tot)                              | Low  | Low  | 2                  |
| WS.SW-AG.SM-compost     | Application of organic fertiliser – compost (from settlement waste)   | N(org)                              | Low  | Low  | 2                  |
| WS.WW-AG.SM-sludge      | Application of organic fertiliser - sludge  | N(org)                              | See Tab. 9-8   |  | 2                  |
| RW-AG.SM-manure         | Import of manure from animal husbandry  | N(tot)                              | Low (quantities according to nutrient reports for Lower Saxony and NRW )                     | Low  | 2                  |
| AG.SM-AT-gasEm          | NO <sub>x</sub> and N <sub>2</sub> O emissions from the applications of mineral and organic fertilisers and farming organic soils | NO <sub>x</sub><br>N <sub>2</sub> O | see Tab. 3-11  |  | 2 / 4              |
| AG.SM-AT-gasEm          | NH <sub>3</sub> emissions from the application of mineral and organic fertilisers and farming organic soils                       | NH <sub>3</sub>                     | see Tab. 3-11  |  | 3                  |
| AG.SM-AT-N <sub>2</sub> | Denitrification from farming mineral soils and organic soils  | N <sub>2</sub>                      | Very low (data for total UAA)  | High; mean of 14 kg N ha <sup>-1</sup> a <sup>-1</sup> after Well et al. (2016) rough estimate | 4                  |
| AG.SM-MP.FP-crop        | Vegetable products  | N(org)                              | Very low (see DESTATIS Quality report)   | Very low   | 1                  |
| AG.SM-AG.AH-crop        | Feed from internal production   | N(org)                              | Areas: Very low<br>Harvest: Low  | Low  | 2                  |

| Flow code                                   | Description  | N-species     | Uncertainty Quantity structure   | Uncertainty Coefficients  | Level <sup>a</sup> |
|---|--|---------------|--|---|--------------------|
| AG.SM-AG.BP-crop                            | Vegetable biomass from internal production as biogas-substrate                               | N(org)        | Low; quantities and composition of substrate after Häussermann et al. (2018)                                   | Low   | 2                  |
| AG.SM-HY.GW-leach                           | NO <sub>3</sub> <sup>-</sup> leaching from agricultural areas                                | NO3           | Groundwater replenishment from agricultural areas: medium  | MoRE model calculation, NO <sub>3</sub> <sup>-</sup> concentration in groundwater: high | 4                  |
| AG.SM-HY.SW-runoff                          | N-discharge from agricultural areas into surface waters due to runoff, erosion, and drainage | NO3<br>N(org) | Outflow volumes Runoff, Erosion and drainage: high   | High  | 4                  |
| <b>Sub-Pool “Biogas Production” (AG.BP)</b> |  |               |  |   |                    |
| MP.FP-AG.BP-cosub                           | Biogas co-substrate (non-agricultural biomass)   | N(org)        | Low; quantities and composition of substrate after Häussermann et al. (2018)                                   | Low   | 2                  |
| AG.AHM-AG.BP-manure                         | Biogas substrate from farm manure, minus housing and storage losses                          | N(tot)        | Low; quantities and composition of substrate after Häussermann et al. (2018)                                   | Low   | 2                  |
| AG.SM-AG.BP-crop                            | Biogas substrate from on-farm vegetable biomass  | N(org)        | Low; quantities and composition of substrate after Häussermann et al. (2018)                                   | Low   | 2                  |
| AG.BP-AG.SM-digest                          | Digestate as fertiliser  | N(tot)        | Low; uncertainties for output from biogas plants corresponds to uncertainties in the calculation of the inputs | Low   | 2                  |

<sup>a</sup> Level of uncertainty in accordance with Tab. 2-3.

## 8 Forest and semi-natural vegetation (FS)

The “Forest and Semi-natural vegetation” pool covers all natural and semi-natural ecosystems with the exception of agriculture. The most important nitrogen gains are due to atmospheric deposition and N-fixation, against losses due to nitrate leaching into groundwater as the largest outflow from near-natural ecosystems. In managed forests, wood removals take out appreciable quantities of nitrogen, and changes in N-stocks play a greater role in forests than in the other pools. There are three sub-pools:

- ▶ Forest (FS.FO)
- ▶ Other Land covered with semi-natural vegetation (FS.OL)
- ▶ Wetland (FS.WL).

No comprehensive statistics are available for the most important N-flows of the “Forest and Semi-natural vegetation” pool. The registration and evaluation of the relevant data sources is therefore covered in more detail than in most of the other pools. Tab. 8-1 gives an overview of the relevant nitrogen flows.

Table 8-1: Incoming and outgoing N-flows of the sub-pools in the “Forest and Semi-natural vegetation” pool.

| Pool(ex)  | Pool(in) | Flow code                 | Description  | N-species                          | Chapter |
|---|----------|---------------------------|--|------------------------------------|---------|
| <b>Sub-Pool “Forest” (FS.FO)<sup>a</sup></b>                              |          |                           |  |                                    |         |
| AT  | FS.FO    | AT-FS.FO-atmDep           | Atmospheric N-deposition on forest areas                         | NH <sub>v</sub> , NO <sub>x</sub>  | 3.4     |
| AT  | FS.FO    | AT-FS.FO-Nfix             | Biological nitrogen fixing in forest soils                       | N(org)                             | 8.1.2   |
| RW  | FS.FO    | RW-FS.FO-wood             | Import of round wood   | N(org)                             | 8.1.5   |
| SOURCE  | FS.FO    | SOURCE-FS.FO <sup>a</sup> | Change of N-stock in soil  | N(org)                             | 8.1.6   |
| FS.FO   | AT       | FS.FO-AT-N2               | Denitrification in forest soils                                  | N <sub>2</sub>                     | 8.1.3   |
| FS.FO   | AT       | FS.FO-AT-gasEm            | NO <sub>x</sub> and N <sub>2</sub> O emissions from forest soils | NO <sub>x</sub> , N <sub>2</sub> O | 3.2.1   |
| FS.FO   | EF.EC    | FS.FO-EF.EC-wood          | Wood removals for energetic use - large combustion plants        | N(org)                             | 8.1.5   |
| FS.FO   | EF.OE    | FS.FO-EF.OE-wood          | Wood removals for energetic use – private households             | N(org)                             | 8.1.5   |
| FS.FO   | MP.OP    | FS.FO-MP.OP-wood          | Wood removals for material use                                   | N(org)                             | 8.1.5   |
| FS.FO   | HY.GW    | FS.FO-HY.GW-leach         | Nitrate leaching from forest soils                               | NO <sub>3</sub> <sup>-</sup>       | 8.1.4   |
| FS.FO   | RW       | FS.FO-RW-wood             | Export of round wood   | N(org)                             | 8.1.5   |
| FS.FO   | SINK     | FS.FO-SINK <sup>a</sup>   | Growth in wood stocks  | N (org)                            | 8.1.6   |
| <b>Sub-Pool “Other land covered with semi-natural vegetation” (FS.OL)</b> |          |                           |  |                                    |         |
| AT  | FS.OL    | AT-FS.OL-atmDep           | Atmospheric N-deposition on semi-natural areas                   | NH <sub>v</sub> , NO <sub>x</sub>  | 3.4     |
| AT  | FS.OL    | AT-FS.OL-Nfix             | Biological nitrogen fixing in semi-natural areas                 | N(org)                             | 8.2.1   |
| FS.OL   | AT       | FS.OL-AT-N2               | Denitrification in semi-natural areas                            | N <sub>2</sub>                     | 8.2.2   |



| Pool(ex)                           | Pool(in) | Flow code          | Description  | N-species                          | Chapter |
|------------------------------------|----------|--------------------|--|------------------------------------|---------|
| FS.OL                              | HY.GW    | FS.OL-HY.GW-leach  | Nitrate leaching from semi-natural areas                             | NO <sub>3</sub> <sup>-</sup>       | 8.2.3   |
| <b>Sub-Pool “Wetlands” (FS.WL)</b> |          |                    |  |                                    |         |
| AT                                 | FS.WL    | AT-FS.WL-atmDep    | Atmospheric N-deposition on wetlands                                 | NH <sub>y</sub> , NO <sub>x</sub>  | 3.4     |
| AT                                 | FS.WL    | AT-FS.WL-Nfix      | Biological nitrogen fixing in wetlands                               | N(org)                             | 8.3.1   |
| AG.SM                              | FS.WL    | AG.SM-FS.WL-runoff | N-input with inflow of runoff from adjacent arable land              | NO <sub>3</sub> <sup>-</sup>       | 8.3.2   |
| FS.WL                              | AT       | FS.WL-AT-N2        | Denitrification in wetlands  | N <sub>2</sub>                     | 8.3.3   |
| FS.WL                              | AT       | FS.WL-AT-gasEm     | NO <sub>x</sub> and N <sub>2</sub> O emissions from wetlands (LULCC) | NO <sub>x</sub> , N <sub>2</sub> O | 3.2.1   |

<sup>a</sup> The mobilisation or immobilisation of N(org) with the increase or decrease of stocks in soil humus and in tree stands are not considered as N-flow in NNB (ECE 2013).

## 8.1 Sub-pool “Forest” (FS.FO)

The German Federal Forest Act defines forest as any area covered with forest vegetation (also referred to in the industry as timberland). This includes areas on which there are no trees (currently or permanently), but which form part of the forest spatially and/or functionally. Examples of “unstocked” areas are forest tracks, openings and clearings, feeding grounds for game, timber storage areas, overgrown heaths and moorland, and rough pastures. Land registries require forests parcels to have an area of at least 0.1 hectare, and to be at least 10 metres wide.

### 8.1.1 Forest area

In the 3<sup>rd</sup> National Forest Inventory 2012 (Thünen Institute 2016c), the forest areas in Germany were registered in detail (Tab. 8-2). A time series and area data covering the years 2010 – 2014 is not available, so that the data for 2012 is used here to calculate the N-flows.

Table 8-2: Forest areas (in 1000 ha) according to specifications, 3rd National Forest Inventory 2012 (Thünen Institute 2016c, Tab. 1.01).

| Forest specification |                     |                                 |        |
|----------------------|---------------------|---------------------------------|--------|
| Forest (total)       | 11,419 <sup>a</sup> | Unstocked areas <sup>b</sup>    | 365    |
|                      |                     | Timberland <sup>c</sup>         | 11,055 |
|                      |                     | Stocked timberland <sup>d</sup> | 11,012 |
|                      |                     | Temporarily unstocked area      | 42     |

<sup>a</sup> Areas differ from values in Tab. 3-2 due to differing definitions.

<sup>b</sup> Parts of the forest not used to grow timber, e.g. paths or clearings more than 5 m wide and timber storage areas.

<sup>c</sup> Timberland: Areas permanently used to grow trees, but including drainage ditches, line corridors, temporarily unstocked areas, and paths and clearings less than 5 m wide.

<sup>d</sup> Stocked timberland: timberland on which trees are growing.

### 8.1.2 Biological nitrogen fixation in forest soils (AT-FS.FO-Nfix)

Figures for symbiotic and non-symbiotic nitrogen fixation in forests are only found sporadically in the literature. In NNB Annex 4, Table 5 (ECE 2016) reference values of 6.5 - 26.6 kg N ha<sup>-1</sup> a<sup>-1</sup> are provided for N-fixation for temperate forests (Cleveland et al. 1999). Boring et al. (1988) give a value of >100 kg N ha<sup>-1</sup> a<sup>-1</sup>. For the calculation of N-flows in Germany a moderate value of 10 kg N ha<sup>-1</sup> a<sup>-1</sup> is used.

$$\text{N-fixation: } 10 \text{ kg N ha}^{-1} \text{ a}^{-1} \times 11,055 \text{ kha} = 110.5 \text{ kt N a}^{-1}.$$

This value for the N-fixation involves considerable uncertainty and represents a placeholder.

### 8.1.3 Denitrification in forest areas (AT-FS.FO.N2)

In a modified approach to calculating the Critical Loads for forest areas, Andreae et al. (2016; Section 5.5.3) use a mean value of 1.1 kg N ha<sup>-1</sup> a<sup>-1</sup> for denitrification in forest soils. Taking this value for timberland areas gives:

$$\text{Denitrification: } 1.1 \text{ kg N ha}^{-1} \text{ a}^{-1} \times 11,055 \text{ kha} = 12.2 \text{ kt N a}^{-1}.$$

### 8.1.4 Nitrate leaching from forest soils (FS.FO-HY.SW-leach)

Nitrate leaching from forest soils depends on various factors, including local conditions (precipitation, seepage water rates, temperature), soil type, nitrogen deposition, and C/N ratio in pines or leaves (Dise et al. 2009). The results for nitrate leaching from forest soils are summarised in Tab. 8-3.

Table 8-3: Literature results for nitrate leaching under forest areas (after Beisecker et al. 2012; with additions).

| Source                     | Region / Period                 | Method   | Mean / Median / Range  | Comment  |
|----------------------------|---------------------------------|--|--|--|
| Borken and Matzner (2004)  | Germany<br>1996-2001            | CL-Balance method<br>57 Level-II forest areas          | Median:<br>4.6 kg N ha <sup>-1</sup> a <sup>-1</sup> (C/N < 25)<br>0.8 kg N ha <sup>-1</sup> a <sup>-1</sup> (C/N > 25)<br>Range: 0 - 26 kg N ha <sup>-1</sup> a <sup>-1</sup> | 71% of areas<br>< 5 kg N ha <sup>-1</sup> a <sup>-1</sup>  |
| Callesen et al. (1999)     | Denmark<br>111 forest locations | Nitrate inventory<br>(1986-1993)                       | 30 % of sites with 2 - 6 kg N-loss ha <sup>-1</sup> a <sup>-1</sup>  |  |
| Kiese et al. (2011)        | Germany<br>2000                 | Bio-geochemical Model FOREST-DNDC, 79 forest locations | Mean: 5.5 kg N ha <sup>-1</sup> a <sup>-1</sup><br>Range: 0 - 80 kg N ha <sup>-1</sup> a <sup>-1</sup>   | 66% of areas<br>< 5 kg N ha <sup>-1</sup> a <sup>-1</sup>  |
| Heldstab et al. (2010)     | Switzerland<br>2005             | Nitrogen balance                                       | Mean: 6.7 kg N ha <sup>-1</sup> a <sup>-1</sup>  | Estimated value  |
| MacDonald et al. (2002)    | Europe<br>1980-1998             | 181 forests<br>Statistical evaluation                  | Mean: 5.8 kg N ha <sup>-1</sup> a <sup>-1</sup><br>Range: 1 - 40 kg N ha <sup>-1</sup> a <sup>-1</sup>   | 64 % of areas<br>< 5 kg N ha <sup>-1</sup> a <sup>-1</sup><br>23 % of areas:<br>5 - 15 kg N ha <sup>-1</sup> a <sup>-1</sup> |
| van der Salm et al. (2007) | Europe<br>2000                  | 110 areas,<br>Regression analysis                      | Median: ~2 kg N ha <sup>-1</sup> a <sup>-1</sup><br>Range: 0 – 18 kg N ha <sup>-1</sup> a <sup>-1</sup>  |  |

The results for means or medians reported by Borken and Matzner (2004), Kiese et al. (2011), Heldstab et al. (2010), and MacDonald et al. (2002) are all in the range 5 to 7 kg N ha<sup>-1</sup> a<sup>-1</sup>. Andreae et al. (2016; Section 5.5.3) use a modified approach to calculate the critical loads for forest areas in Germany as “average tolerable N-removal rate” in leachate of 5.2 kg N ha<sup>-1</sup> a<sup>-1</sup>. As mean for the calculations of N-

flow with leachate from forest areas, a value of  $5.5 \text{ kg N ha}^{-1} \text{ a}^{-1}$  is used in the following after Kiese et al. (2011). The timberland area is used, because the results in the literature do not include unstocked forest areas.

$$\text{NO}_3^- \text{ leaching from forest soils: } 5.5 \text{ kg N ha}^{-1} \text{ a}^{-1} \times 11,054 \text{ kha} = 60.8 \text{ kt N a}^{-1}.$$

Forest management activities, in particular the clearance of larger areas, disturbs the dynamic equilibrium of N-transformations. As a consequence, for some years the nitrate outflows in a cleared area may exceed  $100 \text{ kg N ha}^{-1} \text{ a}^{-1}$  (Beisecker et al. 2012). Assuming mean rotation periods of 80 years for pine trees and 120 years for deciduous trees, then on average about 1 % of the forest area will show elevated  $\text{NO}_3^-$  outflows in any year. These incidents of temporarily increased  $\text{NO}_3^-$  levels are not taken into consideration in the figures for nitrate leaching under forests in the literature.

### 8.1.5 Wood removal and uses of wood (FS.FO-MP.OP-wood, FS.FO-EF.OE-wood, FS.FO-RW-wood, RW-FS.FO-wood)

Data on felling and the removal of wood from forests are available from three sources:

- ▶ Federal Statistical Office (GENESIS-Table No. 41261-0001), annual mean for 2010 - 2014: Annual wood removal  $\sim 54$  million  $\text{m}^3$  (timber under bark).
- ▶ Thünen Institute of International Forestry and Forest Economics (Thünen Institute 2016a), annual mean for 2010 – 2014: Annual felling 73.9 million  $\text{m}^3$ .
- ▶ 3rd National Forest Inventory (BMEL 2016), mean 2002 - 2012: 76 million  $\text{m}^3$  of round wood used annually.

These differences are attributed by the Thünen Institute to various gaps in the data of the Federal Statistical Office. For example, according to the Thünen Institute (2015), in the past decade only some 48 % of the timber removed for firewood was registered by the Federal Statistical Office due to gaps in the data for energetic use of wood from private forests. The results of the 3<sup>rd</sup> National Forest Inventory (BMEL 2016) also indicate that the amount of round wood used annually is underestimated in the official statistics. Jochem et al. (2015) developed a model to calculate realistic figures for felling which draws on “official statistics, association statistics, and the results of empirical investigations for a back-calculation of the quantities of timber felled in Germany” (Thünen Institute 2016a, revised Thünen Institute 2016b).

Nitrogen flows with wood (see Tab. 8-4) are determined in the following using the statistics for wood removal (coarse wood and non-coarse wood) and wood use of the Thünen Institute (after Jochem et al. 2015; Thünen Institute 2016b). These statistics also include data on imports and exports of wood, as well as changes in stocks. For simplicity and greater clarity, the N-flows with the import and export of round wood are included in this sub-pool rather than in the “Materials and Products in Industry” pool.

Table 8-4: Annual N-flows with the removal and use of wood as well as imports and exports (Thünen Institute 2016a), annual mean for 2010 - 2014.

| Use N-flow   | Type of wood | Wood<br>10 <sup>6</sup> x m <sup>3</sup> | Wood<br>10 <sup>6</sup> x t | Wood <sup>b</sup><br>t N | N-flow<br>kt N a <sup>-1</sup> |
|--|--------------|--|-----------------------------|--------------------------|--------------------------------|
| Total removal <sup>a</sup>   | Pine wood    | 52.16                                    | 21.39                       | 25,668                   | 43.3                           |
|  | Deciduous    | 21.71                                    | 12.59                       | 17,626                   |                                |
|  | Combined     | 73.87                                    | 33.98                       | 43,294                   |                                |
| Material use,<br>Total <sup>c</sup>                                | Pine wood    | 45.92                                    | 18.83                       | 22,596                   | 27.2                           |
|  | Deciduous    | 5.67                                     | 3.29                        | 4,606                    |                                |
|  | Combined     | 51.59                                    | 22.12                       | 27,202                   |                                |
| Energetic use<br>Private households <sup>d</sup>                   | Pine wood    | 8.91                                     | 3.65                        | 4,380                    | 14.6                           |
|  | Deciduous    | 12.57                                    | 7.29                        | 10,206                   |                                |
|  | Combined     | 21.48                                    | 10.94                       | 14,586                   |                                |
| Large combustion<br>plants   | Pine wood    | 2.63                                     | 1.08                        | 1,294                    | 3.6                            |
|  | Deciduous    | 2.84                                     | 1.65                        | 2,306                    |                                |
|  | Combined     | 5.47                                     | 2.73                        | 3,600                    |                                |
| Trade<br>Import  | Pine wood    | 7.39                                     | 3.03                        | 3,636                    | 4.3                            |
|  | Deciduous    | 0.80                                     | 0.46                        | 650                      |                                |
|  | Combined     | 8.19                                     | 3.49                        | 4,285                    |                                |
| Export   | Pine wood    | 2.44                                     | 1.00                        | 1,200                    | 2.2                            |
|  | Deciduous    | 1.19                                     | 0.69                        | 966                      |                                |
|  | Combined     | 3.63                                     | 1.69                        | 2,167                    |                                |
| Change in<br>stocks<br>Forest (including<br>industry) <sup>e</sup> | Pine wood    | -0.34                                    | -0.14                       | -167                     | 0.0                            |
|  | Deciduous    | 0.24                                     | 0.14                        | 195                      |                                |
|  | Combined     | -0.10                                    | 0.00                        | 28                       |                                |

<sup>a</sup> Removal: Felling minus unused coarse wood.

<sup>b</sup> Wood density hardwood 0.58 t m<sup>-3</sup>, mean softwood 0.41 t m<sup>-3</sup> after ECE (2016), Annex 4, Table 15; mean N-contents Pine wood 1.2 g kg<sup>-1</sup>, Deciduous 1.4 g kg<sup>-1</sup>, after ECE (2016), Annex 4, Table 16.

<sup>c</sup> For use as veneer, wood and cellulose, sawmill industry, industrial application.

<sup>d</sup> Allocation here according to final use, i.e. charcoal, pellets and briquettes are included under energetic use.

<sup>e</sup> The change in stocks for "Industry" is slight and as a simplification is included under "Forest".

### 8.1.6 Balance and changes in stocks for the "Forest" sub-pool (wood stands and forest soils)

#### N-stock in soil and changes in stock

The status of forest soils in Germany was determined in the course of the first and second National Forest Soil Survey (BZE I, 1987-1993 and BZE II, 2006-2008) for some 1800 systematically distributed sampling points (Andreae et al. 2016). According to BZE II, the N stocks in surface humus and in mineral soils to a depth of 60 cm are on average 6.01 ± 0.08 t N ha<sup>-1</sup>, while a further 1.03 ± 0.03 t N ha<sup>-1</sup> is stored in the layer 60 – 90 cm. At this level, however, a large proportion of the N-contents (44 %) is near or below the limit of detection, so there is considerable uncertainty (Andreae et al. 2016, Section 5.2.1). In total, this corresponds to a N-stock in forest soils of ~78,000 kt N (surface humus – 90 cm depth). For some 1200 sampling points, the change in N-stock in soils can be determined by comparing the values from BZE I and BZE II (Tab. 8-5).

Table 8-5: Mean, standard error and median of the annual change in nitrogen stores ( $\text{kg N ha}^{-1} \text{a}^{-1}$ ) in surface humus and in soil (for a range of depths) in German forests, calculated on the basis of the National Forest Soil Surveys BZE II (2006 - 2008) and BZE I (1987 - 1993) (Andreae et al. 2016, Tab. I-5-1).

| Layer                         | Mean                     | Standard error | Median      | No. of samples <sup>a</sup> |
|-------------------------------|--------------------------|----------------|-------------|-----------------------------|
| Surface humus                 | -1.6                     | 1.4            | -2.6        | 1244                        |
| 0 - 5 cm                      | 6.1*                     | 1.3            | 6.5         | 1325                        |
| 5 - 10 cm                     | 1.1                      | 1.1            | 1.9         | 1327                        |
| 10 - 30 cm                    | -6.3                     | 3.4            | -3.8        | 1312                        |
| 30 - 60 cm                    | -22.3*                   | 7.0            | -14.8       | 1268                        |
| (60 - 90 cm)                  | (-26.7)                  | (8.7)          | (-12.3)     | (1097)                      |
| <b>Surface humus to 60 cm</b> | <b>-26.5<sup>b</sup></b> | <b>11.9</b>    | <b>-8.9</b> | <b>1168</b>                 |

\* statistically significant change ( $p < 5\%$ ).

<sup>a</sup> No. of paired samples.

<sup>b</sup> This value from Andreae et al. (2016), Tab. I-5-1 does not correspond to the total for all layers to 60 cm.

Only the values from the surface humus to a depth of 60 cm are included for the calculation of the change of N-stock in soil, due to the considerable uncertainty for the 60 – 90 cm layer The timberland area is used because the National Forest Soil Surveys do not take samples in unstocked forest areas.

Annual change of N-stock in soil (surface humus to 60 cm depth):

$$-26.5 \text{ kg N ha}^{-1} \text{a}^{-1} \times 11,054 \text{ kha} = -292.9 \text{ kt N a}^{-1} \text{ (corresponds to a mobilisation of } N_r \text{ ("SOURCE"))}.$$

On average, there was a period of 17 years between taking the first and the second BZE samples. Calculated over this period, the mean reduction per annum in Tab. 8-5 corresponds to a change in the N-stock in soils (surface humus to 60 cm depth) of some  $-450 \text{ kg N ha}^{-1}$ . Relative to the total of  $\sim 6000 \text{ kg N ha}^{-1}$  in soils (surface humus to a depth of 60 cm) this represents a change  $-7.5\%$  over 17 years. Humus depletion in forest soils of the same order is reported by Prietzel et al. (2016) for an area of  $4,500 \text{ km}^2$  in the Bavarian Alps. The authors attribute a mean loss of humus of  $14\%$  over three decades primarily to climate change.

### Wood stands and changes in stands

The 3<sup>rd</sup> National Forest Inventory (2012) gives details of timber stocks (Thünen Institute 2016c; bwi.info/, Tab. 3.04) and changes since the 2<sup>nd</sup> Forest Inventory (ibid, Tab. 4.03), from which it is possible to calculate the change in the amount of nitrogen in the standing timber (Tab. 8-6).

Table 8-6: Timber stocks (2012) and changes between 2002 and 2012 in forests according to the National Forest Inventory 2012 (Thünen Institute 2016c).

|                   | Timber stocks (2012)     |                          |                   | Change 2002 to 2012      |                          |                   |
|-------------------|--------------------------|--------------------------|-------------------|--------------------------|--------------------------|-------------------|
|                   | $10^6 \times \text{m}^3$ | $10^6 \times \text{t}^a$ | kt N <sup>b</sup> | $10^6 \times \text{m}^3$ | $10^6 \times \text{t}^a$ | kt N <sup>b</sup> |
| Deciduous forest  | 1420.6                   | 823.9                    | 1153.5            | 175.7                    | 101.9                    | 142.7             |
| Coniferous forest | 2242.4                   | 919.4                    | 1103.3            | 51.7                     | 21.2                     | 25.4              |
| Forest, total     | 3663.0                   | 1743.3                   | 2256.8            | 227.4                    | 123.1                    | 168.1             |

<sup>a</sup> Density for hardwood  $0.58 \text{ t m}^{-3}$ , pine wood  $0.41 \text{ t m}^{-3}$  after NNB Annex 4, Table 15 ECE (2016).

<sup>b</sup> Mean N-contents pine wood  $1.2 \text{ g kg}^{-1}$ , Deciduous  $1.4 \text{ g kg}^{-1}$ , after NNB Annex 4, Table 16 ECE (2016).

The mean annual change in stocks corresponds to one tenth of the total change between the survey years 2002 and 2012.

Annual N-contents in the increased timber stocks in forests = 16.8 kt N a<sup>-1</sup> (corresponds to a binding of N<sub>r</sub> ("SINK")).

### Balance for the "Forest" sub-pool

Tab. 8-7 presents nitrogen inflows and outflows and changes in stock in the "Forest" sub-pool. In contrast to the NNB system (ECE 2013), the release or binding of nitrogen by changes of N-stocks in soil and in timber stands are included as N-flows. The considerable discrepancy of 451 kt N a<sup>-1</sup> between the N-inflows and the N-outflows reflects the considerable uncertainties about the origins and above all the fate of reactive nitrogen in the forest ecosystem at present. Processes such as N-fixation, denitrification, and nitrate leaching cannot be quantified with the precision needed to present anything even close to a balanced budget for N-flows in the "Forest" sub-pool.

Table 8-7: Nitrogen inflows and outflows and changes in stock in the "Forest" sub-pool, annual mean for 2010 - 2014.

| Inflow (N <sub>r</sub> -sources)      | kt N a <sup>-1</sup> | Outflow (N <sub>r</sub> -use)                  |                     |
|---------------------------------------|----------------------|--|---------------------|
|                                       |                      |  | t N a <sup>-1</sup> |
| Atmospheric N-deposition              | 181.1                | Denitrification                                | -12.2               |
| Nitrogen fixing                       | 110.6                | N <sub>2</sub> O and NO <sub>x</sub> emissions | -0.3                |
| Change (reduction) in N-stock in soil | 292.9                | Nitrate leaching                               | -60.8               |
| Net import round wood                 | 2.1                  | Wood removal (all uses)                        | -45.4               |
|                                       |                      | Increase in timber stocks                      | -16.8               |
| <b>Total inflows</b>                  | <b>586.7</b>         | <b>Total outflows</b>                          | <b>-135.5</b>       |
| <b>Difference: 451.2</b>              |                      |  |                     |

## 8.2 Sub-pool "Other land covered with semi-natural vegetation" (FS.OL)

The "Other land" sub-pool combines areas with various types of vegetation cover or with little or no vegetation (e.g. bare rocks, sand dunes). The areas have in common that they are largely in a near-natural state, are subject if at all to only to very extensive anthropogenous use, with nitrogen almost exclusively by natural processes (N-fixation, deposition, runoff, leaching, and denitrification). For the description of the N-flows in Germany, the following classes of CLC 2010 are allocated to this sub-pool (in brackets: CLC-Code; see Tab. 3-2):

- ▶ Natural grasslands (321)
- ▶ Moors and heathland (322)
- ▶ Beaches, dunes, sands (331)
- ▶ Bare rocks (332)
- ▶ Sparsely vegetated areas (333)
- ▶ Glaciers and perpetual snow (335)
- ▶ Inland marshes (411)
- ▶ Salt marches (421)
- ▶ Intertidal flats (423).

### 8.2.1 Biological nitrogen fixing in Other land (AT-FS.OL-Nfix)

Hardly any information about biological nitrogen fixing in soils with semi-natural vegetation is to be found in the literature. In NNB Annex 4, Table 5 (ECE 2016), a reference range of 2.3 to 3.1 kg N ha<sup>-1</sup> a<sup>-1</sup> is given for N-fixation in grassland (original source: Cleveland et al. 1999). For the calculation of the N-flows in Germany, we use a value of 3 kg N ha<sup>-1</sup> a<sup>-1</sup>.

N-fixation: 3 kg N ha<sup>-1</sup> a<sup>-1</sup> x 656.5 kha = 2.0 kt N a<sup>-1</sup>.

This result for biological N-fixation involves considerable uncertainty and represents a placeholder.

### 8.2.2 Denitrification in Other land (AT-FS.OL-N2)

The literature offers only sparse details on denitrification in areas with semi-natural vegetation. As for forests, a value of 1 kg N ha<sup>-1</sup> a<sup>-1</sup> is used for the calculation of the N-flows.

Denitrification: 1 kg N ha<sup>-1</sup> a<sup>-1</sup> x 656.5 kha semi-nat. areas = 0.7 kt N a<sup>-1</sup>.

This result for the denitrification involves considerable uncertainty and represents a placeholder.

### 8.2.3 Nitrate leaching from Other land (FS.OL-HY.SW-leach)

Information about nitrate leaching from areas with semi-natural vegetation are not available in the literature for Germany. Nitrate leaching is calculated using a value of 5 kg N ha<sup>-1</sup> a<sup>-1</sup>, as for Forests.

NO<sub>3</sub><sup>-</sup> leaching from Other land: 5 kg N ha<sup>-1</sup> a<sup>-1</sup> x 656.5 kha = 3.3 kt N a<sup>-1</sup>.

This result for nitrate leaching involves considerable uncertainty and represents a placeholder.

## 8.3 Sub-pool “Wetlands” (FS.WL)

In Germany, the term equivalent to Wetlands (*Feuchtgebiet*) is defined differently in different special fields:

1. Hydrology: Land surfaces that are completely saturated with water or covered with water over long periods every year.
2. Soil science: Areas with characteristic hydro-morphological soil types (e.g. gley).
3. Botany: Areas with vegetation types characteristic of wet areas, e.g. moors, and marshes.

In the 2006 IPCC Guidelines - Consistent Representation of Lands and in the National Inventory Report for Germany (UBA 2016a), wetlands are listed as Category 4.D. Under the CORINE nomenclature, they are allocated to the land use categories “Maritime wetlands” and “Inland wetlands”, the latter with the Level 3 land use classes “Inland marshes” and “Peat bogs”. However, the NNB system (ECE 2013) includes N-flows due to leaching or similar transformations of water-borne N<sub>r</sub> to the “Hydrosphere” pool. In the NNB, wetland therefore only corresponds to the CLC-Land use class “Peat bogs” (see Table 3-2).

### 8.3.1 Biological nitrogen fixation in Wetland (AT-FS.WL-Nfix)

There are very few details in the literature on biological nitrogen fixation in Wetland. In NNB Annex 4, Table 19 (ECE 2016) reference values are given for N-fixation in wetlands (“peat bog”) of 0 to 22 kg N ha<sup>-1</sup> a<sup>-1</sup>. For the calculation of N-flows in Germany, a value of 10 kg N ha<sup>-1</sup> a<sup>-1</sup> was used.

N-fixation: 10 kg N ha<sup>-1</sup> a<sup>-1</sup> x 74.8 kha Wetland = 0.7 kt N a<sup>-1</sup>.

This value for N-fixation involves considerable uncertainty and represents a placeholder.



### 8.3.2 N-inflow with runoff (AG.SM-FS.WL-runoff)

Wetland is characterised as a rule by the inflow of water from adjacent landscape areas, surface ‘runoff’ from agricultural areas, and inflows and outflows of groundwater, transporting quantities of  $\text{NO}_3^-$ . However, no data are known about the discharge volume of the water flows and the associated N-inflow rates in Wetland. In view of the very small areas of wetland in Germany, this N-flow is not considered further.

### 8.3.3 Denitrification in Wetland (AT-FS.WL-N2)

A review of the literature by Gutknecht et al. (2006) shows a wide range of values for denitrification rates in wetlands. As a lower value, we chose a rate von  $20 \text{ kg N ha}^{-1} \text{ a}^{-1}$ .

Denitrification:  $20 \text{ kg N ha}^{-1} \text{ a}^{-1} \times 74.8 \text{ kha Wetland} = 1.5 \text{ kt N a}^{-1}$ .

This result for denitrification involves considerable uncertainty and represents a placeholder.

### 8.3.4 Nitrate leaching from Wetland (FS.WL-HY.SW-leach)

Wetland is typically characterised by the inflow of water as runoff and/or underground flows of groundwater. As a first approximation it can therefore be assumed that over the year such locations experience no (net) groundwater recharge and thus there is no nitrate leaching. In view of the very small areas of wetland in Germany, nitrate leaching here is not considered further.

## 8.4 Summary of N-flows for the “Forest and Semi-natural vegetation” (FS) pool

Table 8-8 shows a summary of the N-flows for the “Forest and semi-natural vegetation” pool.

Table 8-8: Incoming and outgoing N-flows of the sub-pools of the “Forest and semi-natural vegetation” pool, annual mean for 2010 – 2014.

| Pool(ex)                                     | Pool(in) | Flow code                 | Description  | N-species  | N-flow<br>kt N a <sup>-1</sup> |
|--|----------|---------------------------|--|------------|--------------------------------|
| <b>Sub-Pool “Forest” (FS.FO)<sup>a</sup></b> |          |                           |  |            |                                |
| AT   | FS.FO    | AT-FS.FO-atmDep           | Atmospheric N-deposition on forest areas                                 | NHy<br>NOx | 118,9<br>62,2                  |
| AT   | FS.FO    | AT-FS.FO-Nfix             | Biological nitrogen fixing in forest soils                               | N(org)     | 110,5                          |
| RW   | FS.FO    | RW-FS.FO-wood             | Import of round wood   | N(org)     | 4.3                            |
| SOURCE                                       | FS.FO    | SOURCE-FS.FO <sup>a</sup> | Change (reduction) in N-stock in soil                                    | N(org)     | 292.9                          |
| FS.FO  | AT       | FS.FO-AT-N2               | Denitrification in forest soils  | N2         | 12.2                           |
| FS.FO  | AT       | FS.FO-AT-gasEM            | N <sub>2</sub> O and NO <sub>x</sub> emissions from forest areas (LULCC) | N2O<br>NOx | 0.3<br>n.c.                    |
| FS.FO  | EF.EC    | FS.FO-EF.EC-wood          | Wood removal for energetic use - large combustion plants                 | N(org)     | 3.6                            |
| FS.FO  | EF.OE    | FS.FO-EF.OE-wood          | Wood removal for energetic use - private households                      | N(org)     | 14.6                           |
| FS.FO  | MP.OP    | FS.FO-MP.OP-wood          | Wood removal for material use  | N(org)     | 27.2                           |
| FS.FO  | HY.GW    | FS.FO-HY.GW-leach         | Nitrate leaching from forest soils                                       | NO3        | 60.8                           |



| Pool(ex)  | Pool(in) | Flow code          | Description   | N-species  | N-flow<br>kt N a <sup>-1</sup> |
|---|----------|--------------------|---|------------|--------------------------------|
| FS.FO   | RW       | FS.FO-RW-wood      | Export of round wood  | N(org)     | 2.2                            |
| FS.FO   | SINK     | FS.FO-SINK         | Growth of tree stands   | N (org)    | 16.8                           |
| <b>Sub-Pool “Other land covered with semi-natural vegetation” (FS.OL)</b> |          |                    |   |            |                                |
| AT  | FS.OL    | AT-FS.OL-atmDep    | Atmospheric N-deposition on seminatural areas                       | NHy<br>NOx | 5.3<br>2.7                     |
| AT  | FS.OL    | AT-FS.OL-Nfix      | Biological nitrogen fixing in Other land                            | N(org)     | 2.0                            |
| FS.OL   | AT       | FS.OL-AT-N2        | Denitrification in Other land                                       | N2         | 0.7                            |
| FS.OL   | HY.SW    | FS.OL-HY.GW-leach  | Nitrate leaching from Other land                                    | NO3        | 3.3                            |
| <b>Sub-Pool Wetland (FS.WL)</b>   |          |                    |   |            |                                |
| AT  | FS.WL    | AT-FS.WL-atmDep    | Atmospheric N-deposition on wetland                                 | NHy<br>NOx | 0.6<br>0.3                     |
| AT  | FS.WL    | AT-FS.WL-Nfix      | Biological nitrogen fixing in wetland                               | N(org)     | 0.7                            |
| AG.SM   | FS.WL    | AG.SM-FS.WL-runoff | N- inflow as runoff from arable farmland                            | NO3        | n.c.                           |
| FS.WL   | AT       | FS.WL-AT-atmDep    | N <sub>2</sub> O and NO <sub>x</sub> emissions from wetland (LULCC) | N2O<br>NOx | 0.0<br>n.c.                    |
| FS.WL   | AT       | FS.WL-AT-N2        | Denitrification in Wetland  | N2         | 1.5                            |

n.c.: not considered

<sup>a</sup> The mobilisation and binding of N(org) due to increase or decrease in stocks in soil humus and in timber stands is not considered as N-flow in the NNB (ECE 2013).

NO<sub>x</sub> and N<sub>2</sub>O emissions are not shown for the sub-pool “Other land”, because the National Emissions Inventory (see section 3.2) lists no corresponding land use category. The IPCC category “Other Land” covers only a smaller part of semi-natural vegetation and the NO<sub>x</sub> and N<sub>2</sub>O emissions from the land cover there are negligible.

## 8.5 Uncertainty assessment for N-flows of “Forest and Semi-natural vegetation” (FS) pool

Table 8-9 shows the uncertainties in the calculation of the N-flows for the “Forest and Semi-natural vegetation” pool.

Table 8-9: Uncertainties in the calculation of the main N-flows for the “Forest and Semi-natural vegetation” pool.

| Flow code   | Description  | N-species | Uncertainty Quantity structure   | Uncertainty Coefficients  | Level <sup>a</sup> |
|---|--|-----------|--|---|--------------------|
| <b>Sub-Pool “Forest” (FS.FO)</b>  |  |           |  |   |                    |
| AT-FS.FO-atmDep   | Atmospheric N-deposition on forest areas                                       | NHy, NOx  | See Tab. 3-11  |   | 3                  |
| AT-FS.FO-Nfix   | Biological nitrogen fixing in forest soils                                     | N(org)    | Very low; Area figures for “Forest” differ slightly between sources (s. Section 8.1.1)   | High; Range of N-fixation after Cleveland et al. (1999): 6.5 – 26.6 kg N ha <sup>-1</sup> a <sup>-1</sup>   | 4                  |
| FS.FO-AT-N2   | Denitrification in forest soils  | N2        | ditto  | High; mean value 1.1 kg N ha <sup>-1</sup> a <sup>-1</sup> denitrification (no range) after Andreae et al. (2016)   | 4                  |
| FS.FO-EF.OE-wood  | Wood removal for energetic use (large combustion units and private households) | N(org)    | n.d.   | N-contents, stem: 1.2 or 1.4 ±0.5 kg t <sup>-1</sup> (Pine/Deciduous) after ECE (2016) Annex 4, Table 16<br>No details for ranges.  | 2                  |
| FS.FO-MP.OP-wood  | Wood removal for material use  | N(org)    | n.d.   | ditto   | 2                  |
| FS.FO-RW-wood   | Import/Export of round wood  | N(org)    | n.d.   | ditto   | 2                  |
| FS.FO-HY.SW-leach   | Nitrate leaching from forest soils   | NO3       | Very low; Areas figures for “Forest” differ slightly between sources (see Section 8.1.1) | NO <sub>3</sub> <sup>-</sup> leaching according to various investigations (see Tab. 8-3); mean 5.5 kg N ha <sup>-1</sup> a <sup>-1</sup> , range 0 - 80 kg N ha <sup>-1</sup> a <sup>-1</sup> (Kiese et al. 2011) | 3                  |
| Change in stocks  | Change in N-stock in soil  | N(org)    | ditto  | Standard error of change of N-contents: ±11.9 kg N ha <sup>-1</sup> a <sup>-1</sup> (see Tab. 8-5); changes only significant at two depth levels  | 3                  |
| Change in stocks  | Change in N in timber stocks   | N(org)    | Standard error (68%): ± 5.5% for “all tree types” (bwi.info; Tab 4.03)                   | As for FS.FO-EF.OE-wood   | 2                  |
| <b>Sub-Pool “Other land covered with semi-natural vegetation” (FS.OL)</b> |  |           |  |   |                    |
| AT-FS.OL-atmDep   | Atmospheric N-deposition on semi-natural areas                                 | NHy, NOx  | see Tab. 3-11  |   | 3                  |

| Flow code                         | Description                                      | N-species | Uncertainty Quantity structure                                  | Uncertainty Coefficients  | Level <sup>a</sup> |
|-----------------------------------|--|-----------|---|---|--------------------|
| AT-FS.OL-Nfix                     | Biological nitrogen fixing in semi-natural areas | N(org)    | Areas for “Other land” differ between sources (see Section 8.2) | Reference value for N-fixation in natural grasslands 2.3 to 3.1 kg N ha <sup>-1</sup> a <sup>-1</sup> (Cleveland et al. 1999) | 4                  |
| FS.OL-AT-N2                       | Denitrification in Other land                    | N2        | As for AT-FS.OL-atmDep  | Placeholder; no values in the literature for denitrification in areas with semi-natural vegetation for Germany                | 4                  |
| FS.OL-HY.SW-leach                 | Nitrate leaching from other land                 | NO3       | As for AT-FS.OL-atmDep  | Placeholder; no values in the literature for nitrate leaching from areas with semi-natural vegetation for Germany             | 4                  |
| <b>Sub-Pool “Wetland” (FS.WL)</b> |  |           |   |   |                    |
| AT-FS.WL-atmDep                   | Atmospheric N-deposition on forest areas         | NHy, NOx  | see Tab. 3-11   |   | 3                  |
| AT-FS.WL-Nfix                     | Biological nitrogen fixing in Wetland            | N(org)    | Areas for “Wetland” differ between sources (see Section 8.3)    | Reference values for N-fixing in Wetland (“peat bog”) 0 to 22 kg N ha <sup>-1</sup> a <sup>-1</sup>                           | 4                  |
| FS.WL-AT-N2                       | Denitrification in Wetland                       | N2        | As for AT-FS.WL-atmDep  | Literature review by Gutknecht et al. (2006): wide range of denitrification rates in Wetland                                  | 4                  |

n.d.: no data

<sup>a</sup> Level of uncertainty in accordance with Tab. 2-3.

## 9 Waste (WS)

The “Waste” pool includes the collection, treatment, and disposal of solid waste and wastewater, and is sub-divided into two sub-pools. Tab. 9-1 gives an overview of the relevant nitrogen flows. In accordance with NNB (ECE 2013), waste incineration is included here rather than under Energy Conversion.

- ▶ Solid Waste (WS.SW).
- ▶ Wastewater (WS.WW).

Table 9-1: Incoming and outgoing N-flows of the sub-pools in the “Waste” pool.

| Pool(ex)                              | Pool(in)          | Flow code               | Description  | N-species                          | Chapter |
|---------------------------------------|-------------------|-------------------------|--|------------------------------------|---------|
| <b>Sub-Pool “Solid Waste” (WS.SW)</b> |                   |                         |  |                                    |         |
| EF.EC                                 | WS.SW             | EF.EC-WS.SW-waste       | Waste from the production of fuels and refinery products   | N(org)                             | 9.1.1   |
| MP.FP                                 | WS.SW             | MP.FP-WS.SW-fuel        | Bone meal for thermal recycling  | N(org)                             | 5.1.3   |
| MP.OP                                 | WS.SW             | MP.OP-WS.SW-waste       | Waste from Other producing industry  | N(org)                             | 9.1.1   |
| HS.HB                                 | WS.SW             | HS.HB-WS.SW-waste       | Domestic waste (food waste)  | N(org)                             | 9.1.1   |
| HS.MW                                 | WS.SW             | HS.MW-WS.SW-waste       | Waste from consumer goods  | N(org)                             | 9.1.1   |
| WS.WW                                 | WS.SW             | WS.WW-WS.SW-sludge      | Sludge for landfill, disposal as hazardous waste, recycling or other disposal                                    | N(org)                             | 9.2.2   |
| WS.WW                                 | WS.SW             | WS.WW-WS.SW-sludge      | Sludge for thermal disposal  | N(org)                             | 9.2.2   |
| RW                                    | WS.SW             | RW-WS.SW-waste          | Import of waste substances   | N(org)                             | 9.1.3   |
| WS.SW                                 | AT                | WS.SW-AT-gasEM          | NO <sub>x</sub> and N <sub>2</sub> O emissions from waste incineration plants and waste disposal sites           | NO <sub>x</sub> , N <sub>2</sub> O | 3.2     |
| WS.SW                                 | AT                | WS.SW-AT-gasEM          | NH <sub>3</sub> - emissions from waste incineration plants and waste disposal sites                              | NH <sub>3</sub>                    | 3.3     |
| WS.SW                                 | AT                | WS.SW-AT-N <sub>2</sub> | Oxidation/reduction of N <sub>r</sub> to N <sub>2</sub> during waste incineration                                | N <sub>2</sub>                     | 9.1.1   |
| WS.WW                                 | AT                | WS.WW-AT-N <sub>2</sub> | Oxidation/reduction of N <sub>r</sub> to N <sub>2</sub> during the thermal recycling (incineration) of sludge    | N <sub>2</sub>                     | 9.2.2   |
| WS.SW                                 | AT                | WS.WW-AT-N <sub>2</sub> | Oxidation/reduction of N <sub>r</sub> to N <sub>2</sub> during the thermal recycling (incineration) of bone meal | N <sub>2</sub>                     | 5.1.3   |
| WS.SW                                 | MP.OP             | WS.SW-MP.OP-waste       | Material recycling of waste materials  | N(org)                             | 9.1.1   |
| WS.SW                                 | AG.SM             | WS.SW-AG.SM-comp        | Compost (from communal green waste) for use in agriculture   | N(org)                             | 7.2.1   |
| WS.SW                                 | SINK <sup>a</sup> | WS.SW-SINK-waste        | Depositing waste   | N(org)                             | 9.1.1   |
| WS.WW                                 | SINK <sup>a</sup> | WS.WW-SINK-sludge       | Sludge for landfill, disposal as hazardous waste, recycling or other disposal                                    | N(org)                             | 9.2.2   |
| WS.SW                                 | RW                | RW-WS.SW-waste          | Export of waste materials  | N(org)                             | 9.1.3   |

| Pool(ex)                             | Pool(in) | Flow code               | Description   | N-species                          | Chapter |
|--------------------------------------|----------|-------------------------|---|------------------------------------|---------|
| <b>Sub-Pool “Wastewater” (WS.WW)</b> |          |                         |   |                                    |         |
| HS.HB                                | WS.WW    | HS.HB-WS.WW-sewage      | Domestic waste water  | N(tot)                             | 9.2.1   |
| HS.MW                                | WS.WW    | HS.MW-WS.WW-sewage      | Wastewater from settlement areas (sealed areas)   | N(tot)                             | 9.2.1   |
| EF.EC                                | WS.WW    | EF.EC-WS.WW-sewage      | Wastewater from the energy sector   | N(tot)                             | 9.2.1   |
| MP.FP                                | WS.WW    | MP.FP-WS.WW-sewage      | Wastewater from food and feed processing  | N(tot)                             | 9.2.1   |
| MP.NC                                | WS.WW    | MP.FP-WS.WW-sewage      | Wastewater from Nitrogen chemistry  | N(tot)                             | 9.2.1   |
| MP.OP                                | WS.WW    | MP.FP-WS.WW-sewage      | Wastewater from Other producing industry  | N(tot)                             | 9.2.1   |
| WS.WW                                | AT       | WS.WW-AT-gasEm          | NO <sub>x</sub> and N <sub>2</sub> O emissions from Wastewater treatment plants   | NO <sub>x</sub> , N <sub>2</sub> O | 3.3     |
| WS.WW                                | HS.MW    | WS.WW-HS.MW-sludge      | Sludge for use in landscaping measures  | N(org)                             | 9.2.2   |
| WS.WW                                | AG.SM    | WS.WW-AG.SM-sludge      | Sludge for use in agriculture   | N(org)                             | 9.2.2   |
| WS.WW                                | WS.SW    | WS.WW-WS.SW-sludge      | Sludge for landfill, disposal as hazardous waste, recycling or other disposal   | N(org)                             | 9.2.2   |
| WS.WW                                | WS.SW    | WS.WW-WS.SW-sludge      | Thermal recycling of sludge   | N <sub>2</sub> , NO <sub>x</sub>   | 9.2.2   |
| WS.WW                                | HY.SW    | WS.WW-HY.SW-discharge   | N discharge into surface waters from wastewater treatment plants and the sewerage system <sup>b</sup> (settlement water management) | N(tot)                             | 9.2.3   |
| WS.WW                                | AT       | WS.WW-AT-N <sub>2</sub> | Denitrification in municipal and non-public wastewater treatment plants   | N <sub>2</sub>                     | 9.2.4   |

<sup>a</sup> Zu Pool(in) “SINK” see Section 9.4.

<sup>b</sup> N-inflow with discharge from municipal wastewater treatment plants and mixed-water outflows and stormwater sewers, from areas connected to sewers, from areas with septic tanks, and from industrial direct dischargers.

## 9.1 Sub-Pool “Solid Waste” (WS.SW)

The Federal Statistical Office reports annually on waste disposal (DESTATIS 2018, Tab.-No. 2190100187005). Data on waste disposal are collected by authorised operators of plants which collect, treat, recycle or dispose of their own waste or the waste of third parties in whole or in part. The amounts are recorded which are delivered and which then leave the plant. This survey structure means that the report on waste disposal is unsuitable for the clear description of the material flows making up the solid waste, the internal flows between plants, the amounts of materials that are recycled, and finally the amounts that are incinerated or deposited. Rather, there is double counting to an unknown extent at all stages. The waste balance (DESTSATIS 2017c, Tab.-Nr. 52310001) presents amounts of waste according to waste categories and the recycling or disposal paths. The waste balance is not a primary survey, but is determined using a model from the waste management sector. In order

to register N-flows for solid waste various statistics from both publication are utilised. All figures refer to the fresh weight of the waste.

### 9.1.1 Amounts of waste (XX.XX-WS.SW-waste)

In the Table "Waste according to economic sectors" (WZ) of the waste balance (DESTATIS 2017c), amounts of waste are shown in eight economic sectors, of which four (probably) produce nitrogenous waste. The N-flows of these economic sectors are assigned to five sub-pools of NNB as follows (Tab. 9-2):

- ▶ "Energy supplies" -> Sub-pool "Energy conversion" (EF.EC-WS.SW-waste)
- ▶ "Manufacturing sector" -> Sub-pools "Food and feed processing" (MP.FP- WS.SW-waste) and "Other Producing Industry" (MP.OP-WS.SW-waste)
- ▶ "Households" -> Sub-pool "Human body" (HS.HB-EC-WS.SW-waste)
- ▶ "Services" -> Sub-pool "Material world" (HS.MW-WS.SW-waste).

The sub-pool "Nitrogen Chemistry" cannot be allocated an amount of waste, although it can be assumed that relevant quantities of nitrogenous waste are generated there. This quantity is included in the N-flow of sub-pool "Other producing industry". Sludge wastes from waste management facilities, off-site waste water treatment plants and the preparation of water for industrial use are evaluated in the sludge statistics (see Section 9.2.2). Sludge from drinking water preparation does not contain nitrogen and is therefore not included.

Table 9-2: Quantities of waste (only types of waste that probably contain nitrogen) and allocation of sub-pools of origin, annual mean for 2010/2012/2014 (Source: DESTATIS 2012b, 2014b, 2017c).

| Type of waste                                | Quantity of waste <sup>a</sup> (1000 t) |                    |               |                   | N-Content <sup>b</sup> (%) | N-flow (kt N a <sup>-1</sup> )        |                           |                           |                           |
|--|---|--------------------|---------------|-------------------|----------------------------|---------------------------------------|---------------------------|---------------------------|---------------------------|
|  | Manu-<br>facturing<br>sector            | Energy<br>supplies | Services      | Domestic<br>waste |                            | MP.FP- &<br>MP.OP-<br>WS.SW-<br>waste | EF.EC-<br>WS.SW-<br>waste | HS.MW-<br>WS.SW-<br>waste | HS.HB-<br>WS.SW-<br>waste |
| Spent solvents                               | 519                                     | 22                 | 67            | 3                 | 0.3 %                      | 1.6                                   | 0.1                       | 0.2                       | 0.0                       |
| Acid, alkaline or saline wastes              | 954                                     | 28                 | 58            | 1                 | 0.3 %                      | 2.9                                   | 0.1                       | 0.2                       | 0.0                       |
| Chemical wastes                              | 2,075                                   | 69                 | 295           | 24                | 0.3 %                      | 6.2                                   | 0.2                       | 0.9                       | 0.1                       |
| Health care and biological wastes            | 64                                      | 0                  | 232           | 0                 | 0.3 %                      | 0.2                                   | 0.0                       | 0.7                       | 0.0                       |
| Paper and cardboard waste                    | 726                                     | 6                  | 1,696         | 5,562             | 0.1 %                      | 0.7                                   | 0.0                       | 1.7                       | 5.6                       |
| Rubber wastes                                | 350                                     | 6                  | 117           | 0                 | 0.4 %                      | 1.4                                   | 0.0                       | 0.5                       | 0.0                       |
| Plastic wastes                               | 778                                     | 2                  | 510           | 91                | 0.4 %                      | 3.1                                   | 0.0                       | 2.0                       | 0.4                       |
| Waste wood                                   | 3,210                                   | 54                 | 550           | 677               | 0.1 %                      | 3.2                                   | 0.1                       | 0.5                       | 0.7                       |
| Textile wastes                               | 119                                     | 0                  | 57            | 98                | 0.4 %                      | 0.5                                   | 0.0                       | 0.2                       | 0.4                       |
| Discarded equipment (electrical, electronic) | 130                                     | 51                 | 209           | 523               | 0.4 %                      | 0.5                                   | 0.2                       | 0.8                       | 2.1                       |
| Feed and food waste                          | 640                                     | 5                  | 1,031         | 0                 | 1.0 %                      | 6.4                                   | 0.1                       | 10.3                      | 0.0                       |
| Vegetable waste                              | 877                                     | 41                 | 868           | 9,076             | 0.5 %                      | 4.4                                   | 0.2                       | 4.3                       | 45.4                      |
| Animal faeces, urine and manure              | 1,339                                   | 49                 | 3,898         | 15,749            | 4.0 %                      | 5.4                                   | 0.2                       | 15.6                      | 63.0                      |
| Household and similar wastes                 | 2,489                                   | 71                 | 1,375         | 2,584             | 0.4 %                      | 10.0                                  | 0.3                       | 5.5                       | 10.3                      |
| Mixed and undifferentiated materials         | 496                                     | 54                 | 593           | 0                 | 0.4 %                      | 2.0                                   | 0.2                       | 2.4                       | 0.0                       |
| <b>Total</b>                                 | <b>14,765</b>                           | <b>460</b>         | <b>11,556</b> | <b>34,389</b>     |                            | <b>48.4</b>                           | <b>1.6</b>                | <b>45.9</b>               | <b>127.9</b>              |

<sup>a</sup> Not including animal faeces, urine and manure.

<sup>b</sup> N-contents according to NNB Annex 0, Tab. 4 (ECE 2013); BGK (2006; cited from UBA 2012), with some estimates.

### 9.1.2 Disposal and recycling of waste (WS.SW-XX.XX-waste)

The disposal and recycling of waste is shown in the waste balance (DESTATIS 2017c) in the tables “Waste balance [year]” according to disposal and recycling methods. The waste balance is distributed between five paths:

|                    |                          |
|--------------------|--------------------------|
| Disposal methods:  | - Depositing             |
|                    | - Thermal disposal       |
|                    | - Treatment for disposal |
| Recycling methods: | - Energetic recycling    |
|                    | - Material recycling     |

For the presentation of nitrogen flows (Tab. 9-3), the waste balance is interpreted as follows:

- ▶ “Depositing” is used unchanged (WS.SW-SINK-waste).
- ▶ Thermal disposal and energetic recycling are combined as “Combustion” (WS.SW-AT-N2).
- ▶ Material recycling is interpreted as Material recycling of waste materials in Other producing industry (WS.SW-MP.OP-waste).
- ▶ Treatment for disposal deals with waste which is subsequently registered either under Depositing or Thermal disposal, so that this is not taken into consideration here.

The long-term accumulation of a nitrogen sink in the form of deposited waste, which is not provided for in the NNB system, is included here as “SINK” under Pool(in), analogous to Section 4.4.



Table 9-3: Fate of waste, allocation to three N-flows (only probably nitrogenous wastes <sup>a</sup> shown, “hazardous” and “non-hazardous” wastes are combined), annual mean for 2010 - 2014 (Source: DESTATIS 2017c).

| Type of waste  | Waste treatment plant <sup>b</sup> (1000 t) |                  |                     |                    | N-content <sup>c</sup> (%) | N-flow (kt N a <sup>-1</sup> )               |  |   |
|--|---|------------------|---------------------|--------------------|----------------------------|--|--|---|
|  | Depositing                                  | Thermal disposal | Energetic recycling | Material recycling |                            | Depositing<br>WS.SW-SINK <sup>e</sup> -waste | Combustion <sup>d</sup><br>WS.SW-AT-N2 | Material recycling<br>WS.SW-MP.OP-waste |
| Typical settlement waste, of which:                          |   |                  |                     |                    |                            |  |  |   |
| - Domestic waste, comparable commercial waste <sup>f</sup>   | 0   | 5,326            | 5,898               | 1,785              | 0.4 %                      | 0.0  | 44.9                                   | 7.1                                     |
| - Bulky domestic waste                                       | 2   | 357              | 663                 | 1,329              | 0.4 %                      | 0.0  | 4.1                                    | 5.3                                     |
| - Separately collected organic waste                         | 0   | 0                | 30                  | 3,949              | 1.0 %                      | 0.0  | 0.3                                    | 39.5                                    |
| - Bio-degradable waste from garden and parks <sup>g</sup>    | 10  | 1                | 218                 | 4,997              | 0.5 %                      | 0.1  | 1.1                                    | 25.0                                    |
| - Other separately collected groups, thereof                 |   |                  |                     |                    |                            |  |  |   |
| · paper, cardboard   | 0   | 5                | 49                  | 7,897              | 0.1 %                      | 0.0  | 0.1                                    | 7.9                                     |
| · Mixed packaging / Recyclable materials                     | 4   | 243              | 764                 | 4,427              | 0.4 %                      | 0.0  | 4.0                                    | 17.7                                    |
| · Electric appliances  | 0   | 0                | 1                   | 598                | 0.4 %                      | 0.0  | 0.0                                    | 2.4                                     |
| · Others (compound materials, metal, textiles, etc.)         | 12  | 23               | 528                 | 1,420              | 0.4 %                      | 0.0  | 2.2                                    | 5.7                                     |
| Other settlement waste, including:                           |   |                  |                     |                    |                            |  |  |   |
| - Light commercial waste, collected separately               | 9   | 832              | 1,236               | 1,701              | 0.4 %                      | 0.0  | 8.3                                    | 6.8                                     |
| - Road sweepings, garden and park waste                      | 123   | 54               | 43                  | 597                | 0.2 %                      | 0.2  | 0.2                                    | 1.2                                     |
| - Bio-degradable waste from kitchens and canteens            | 0   | 3                | 49                  | 654                | 1.0 %                      | 0.0  | 0.5                                    | 6.5                                     |
| - Market waste   | 0   | 8                | 2                   | 55                 | 1.0 %                      | 0.0  | 0.1                                    | 0.5                                     |
| - Other separately collected types of waste                  | 5   | 10               | 20                  | 132                | 0.4 %                      | 0.0  | 0.1                                    | 0.5                                     |
| Other waste (in particular from production and trade)        | 10,766                                      | 2,857            | 10,354              | 31,033             | 0.4 %                      | 43.1   | 52.8                                   | 124.1                                   |
| Secondary waste from waste treatment operations <sup>h</sup> | 4,531                                       | 1,909            | 13,806              | 24,709             | 0.4 %                      | 18.1   | 62.9                                   | 98.8                                    |
| <b>Totals</b>  | <b>15,462</b>                               | <b>11,627</b>    | <b>33,663</b>       | <b>85,282</b>      |                            | <b>61.6</b>                                  | <b>181.6</b>                           | <b>349.2</b>                            |

Footnotes see next page

- <sup>a</sup> It is assumed that there is no N in waste glass, fluorescent tubes, and waste from extracting minerals, or from building and demolition waste.
- <sup>b</sup> “Treatment for disposal” is not considered, because it is assumed that this waste is then registered either under thermal disposal or landfill.
- <sup>c</sup> N-contents according to NNB Annex 0, Tab. 4 (ECE 2013); BGK (2006; after UBA 2012); with some estimates.
- <sup>d</sup> Combustion: Total of thermal disposal and energetic recycling.
- <sup>e</sup> On Pool(in) “SOURCE” see Section 9.4.
- <sup>f</sup> Collected in the municipal waste collection.
- <sup>g</sup> Including cemetery waste.
- <sup>h</sup> Not including waste from wastewater treatment plants, waste from the purification of drinking water or water for industrial uses, waste from soil refurbishment and groundwater decontamination, and recycled secondary waste.

### 9.1.3 Import and export of waste (RW-WS.SW-waste, WS.SW-RW-waste)

Imports and exports of waste are reported in the table “Trans-boundary shipments of waste to/from Germany in notification procedures” as an element of waste disposal (DESTATIS 2012a, 2013, 2014a, 2015b, 2016). Data is provided there for some 240 types of waste in accordance with the European Waste Catalogue (EWC). Tab. 9-4 shows results in an aggregated form, as published by the German Environment Agency (UBA 2018a, 2018b);

Table 9-4: N-flows with the import and export of notifiable waste materials, annual mean for 2010 – 2014 (UBA 2018a, 2018b).

| Type of waste  | EC Waste Statistics Regulation                    | Import 1000 t | Export 1000 t | N-content | Import kt N a <sup>-1</sup> <sup>a</sup> | Export kt N a <sup>-1</sup> |
|--|---|---------------|---------------|-----------|--|-----------------------------|
| Spent solvents   | 01.11, 01.12                                      | 53            | 24            | 0.3 %     | 0.2                                      | 0.1                         |
| Acid, alkaline or saline wastes  | 01.21, 01.22, 01.24                               | 224           | 16            | 0.3 %     | 0.7                                      | 0.0                         |
| Chemical wastes  | 01.41, 02.11-14, 02.21, 02.22, 02.31-33, 03.12-14 | 318           | 46            | 0.3 %     | 1.0                                      | 0.1                         |
| Health care and biological wastes  | 05.11, 05.12, 05.21, 05.22                        | 2             | 0             | 1.0 %     | 0.0                                      | 0.0                         |
| Paper and cardboard waste  | 07.21-23  | 11            | 103           | 0.1 %     | 0.0                                      | 0.1                         |
| Rubber wastes  | 07.31, 07.32                                      | 0             | 0             | 0.4 %     | 0.0                                      | 0.0                         |
| Plastic wastes   | 07.41, 07.42                                      | 20            | 0             | 0.4 %     | 0.1                                      | 0.0                         |
| Waste wood   | 07.51-53  | 897           | 139           | 0.1 %     | 0.9                                      | 0.1                         |
| Textile wastes   | 07.61-63  | 0             | 0             | 0.4 %     | 0.0                                      | 0.0                         |
| Discarded equipment (large; domestic electronic & electrical appliances) | 08.21, 08.23                                      | 52            | 25            | 0.4 %     | 0.2                                      | 0.1                         |
| Feed and food waste  | 09.11, 09.12, 09.13                               | 4             | 3             | 1.3 %     | 0.1                                      | 0.0                         |
| Vegetable waste  | 09.21, 09.22                                      | 1             | 3             | 1.0 %     | 0.0                                      | 0.0                         |
| Animal excretions  | 09.31   | 0             | 0             | 4.9 %     | 0.0                                      | 0.0                         |
| Household and similar wastes   | 10.11, 10.12                                      | 324           | 153           | 0.4 %     | 1.3                                      | 0.6                         |
| Mixed + undifferentiated materials                                       | 10.21, 10.22                                      | 121           | 15            | 0.4 %     | 0.5                                      | 0.1                         |
| Sorting residues   | 10.32   | 1071          | 376           | 0.4 %     | 4.3                                      | 1.5                         |
| <b>Total imports and export</b>  |   | <b>3097</b>   | <b>904</b>    |           | <b>9.1</b>                               | <b>2.8</b>                  |

## 9.2 Sub-pool “Wastewater” (WS.WW)

A key instrument for assessing nitrogen flows in the “Hydrology” pool and settlement water management is the river basin management system MoRE (Modelling of Regionalized Emissions; Fuchs et al. 2017a). The N-inflows are modelled for the following pathways (see also the introduction to Chapter 10):

- |                 |   |
|-----------------|---|
| Point sources:  | - Municipal wastewater treatment plants<br>- Industrial direct dischargers.   |
| Diffuse sources | - Sewer systems<br>- Runoff<br>- Erosion<br>- Drainage<br>- Groundwater<br>- Atmospheric depositions onto surface waters. |

In addition to modelling the inflows, loads in the hydrosphere are estimated on the basis of the total inflows and substance-related retention.

### 9.2.1 Sewage from households, industry (direct and indirect dischargers) and from sealed areas (EF.EC-WS.WW-sewage, MP.XX-WS.WW-sewage, HS.XX-sewage)

There is no complete survey or calculation of the total N load in wastewater entering the sewerage system from various sources. In order to present the N-inflows into the “Wastewater” sub-pool and to allocate these to individual sources it is therefore necessary to make various assumptions. The starting point is the data from MoRE model, and Tab. 9-5 shows the results.

The N-contents in sewage from households is calculated for a population of 80 million in Germany (mean 2011 - 2014) with a per capita contribution of 12 g N d<sup>-1</sup>. This gives a load of 350.0 kt N a<sup>-1</sup> N in domestic sewage.

The N load in outflow from sealed areas (EEA 2014) of 30 kt N a<sup>-1</sup> is determined using the atmospheric deposition rate for NH<sub>x</sub> and NO<sub>x</sub> (see Section 3.4) plus the so-called surface potential of roads (mainly from falling leaves and animal excrement) of 4 kg N ha<sup>-1</sup> a<sup>-1</sup> (after Behrendt et al. 1999). More than half of this outflow (52 % according to MoRE estimates) reaches the surface waters via mixed-wastewater or stormwater treatment plants that are without N-elimination, and 48 % goes through municipal wastewater treatment plants with N elimination.

The N load of industrial indirect dischargers to municipal wastewater treatment plants is calculated as the difference between the total load in the inflow to municipal wastewater treatment plants (including the industrial indirect dischargers) minus the load from households and the proportion of runoff from sealed areas that is treated in municipal wastewater treatment plants. The total N load in the inflow of municipal wastewater treatment plants is an estimated 454 kt N a<sup>-1</sup>. Subtracting the wastewater loads from households (350 kt N a<sup>-1</sup>) and sealed areas (30.0 kt N a<sup>-1</sup> x 42 % = 12.6 kt N a<sup>-1</sup>) in wastewater treatment plants, then industrial indirect dischargers account for 91.5 kt N a<sup>-1</sup>.

To assess the N-discharge into the wastewater treatment plants from industrial direct dischargers, reference is made to the Pollutant Release and Transfer Register (UBA 2016b). According to the PRTR database, notifiable direct discharges of 8.6 kt N a<sup>-1</sup> are released from wastewater treatment plants into surface waters. Assuming nitrogen elimination rate of 80 % in industrial wastewater treatment plants (analogous to municipal wastewater treatment plants, see Section 9.2.4) this gives a nitrogen load in the direct discharge 43 kt N a<sup>-1</sup>. The combined N-load in wastewater from industry is therefore 134.5 kt N a<sup>-1</sup>.

The NNB Annexes (ECE 2013) envisage differentiating the N-flows in the wastewater from industry for the various sub-pools of “Energy and Fuels” and “Materials and Products in Industry”, but no adequate data is available for Germany. Data about the origins of sewage according to sectors are only available for the direct dischargers in the PRTR-Register, i.e. for a N-load of 8.6 kt N a<sup>-1</sup>. According to the PRTR register, 51 % of this is from the chemical industry, 27 % from the food industry, 6 % from the energy sector, and all other industry accounts for 16 % of the load. In the following, the N-load in wastewater from industrial direct and indirect dischargers is distributed in this ratio to the four sectors or N-flows. It is not possible to determine how valid these assumptions are, so that the values for the four sub-pools in Tab. 9-5 only have a placeholder function.

Table 9-5: N-contents in wastewater (sewage) from households, from sealed areas and from industrial dischargers.

| N-Flow   | N-contents in wastewater (sewage)  | N-species | N-flow<br>kt N a <sup>-1</sup> |
|--|--|-----------|--------------------------------|
| HS.HB-WS.WW-sewage                             | Sewage from households   | N(tot)    | 350                            |
| HS.MW-WS.WW-sewage                             | Wastewater from sealed areas   | N(tot)    | 30.0                           |
|  | Total wastewater from industrial direct and indirect dischargers, of which from: | N(tot)    | 134.5                          |
| EF.EC-WS.WW-sewage                             | - Energy conversion (6 %)  | N(tot)    | 8.1                            |
| MP.FP-WS.WW-sewage                             | - Food and feed processing (27 %)  | N(tot)    | 36.3                           |
| MP.NC-WS.WW-sewage                             | - Nitrogen chemistry (51 %)  | N(tot)    | 68.6                           |
| MP.OP-WS.WW-sewage                             | - Other Producing Industry (16 %)  | N(tot)    | 21.5                           |
| <b>Total N-contents in wastewater (sewage)</b> |  |           | <b>514.4</b>                   |

### 9.2.2 Sludge and sludge disposal (WS.WW-HS.MW-sludge, WS.WW-AG.SM-sludge, WS.WW-WS.SW-sludge)

The amounts of sludge arising from public and non-public wastewater treatment and their modes of disposal are surveyed by the Federal Statistical Office every three years (DESTATIS 2017b). Due to changes in methodology, the data for 2013 can only be compared with earlier years to a limited extent, so that the N-flows in Tab. 9-5 are determined using data only for 2013. The data on the N-contents of sludges recycled in agriculture (45.1 g N<sub>tot</sub> kg<sup>-1</sup> TS, after DESTATIS 2017b) is drawn from the sludge reports of the federal states. Only 0.4 % of sludge is exported, and this very small amount is not shown separately.

Table 9-6: Sludge disposal from public and non-public wastewater treatment, for 2013 (DESTATIS 2017b; Tab. 1.1) and allocation to N-flows.

| Flow code                           | Description   | Sludge<br>1000 t TS | N-<br>species | N-flow<br>kt N a <sup>-1 a</sup> |
|-------------------------------------|---|---------------------|---------------|----------------------------------|
| WS.WW-AG.SM-sludge                  | Material recycling in agriculture                       | 551.6               | N(tot)        | 24.9                             |
| WS.WW-HS.MW-sludge                  | Material recycling in landscaping measures <sup>b</sup> | 280.4               | N(tot)        | 12.6                             |
| WS.WW-HS.MW-sludge                  | Other material recycling <sup>c</sup>                   | 412.7               | N(tot)        | 18.6                             |
| WS.WW-WS.SW-sludge                  | Thermal disposal  | 1605.4              | N(tot)        | 72.4                             |
| WS.WW-WS.SW-sludge                  | Disposal site <sup>d</sup>                              | 207.1               | N(tot)        | 9.3                              |
| WS.WW-WS.SW-sludge                  | Other direct disposal <sup>e</sup>                      | 13.1                | N(tot)        | 0.6                              |
| WS.WW-WS.SW-sludge                  | Disposal as hazardous waste <sup>d</sup>                | 154.3               | N(tot)        | 7.0                              |
| WS.WW-WS.SW-sludge                  | Other disposal / unknown <sup>d</sup>                   | 154.3               | N(tot)        | 7.0                              |
| <b>Total direct sludge disposal</b> |   | <b>3379.6</b>       |               | <b>152.4</b>                     |

<sup>a</sup> N-contents: 45.1 kg N<sub>tot</sub>/t TS (after DESTATIS 2017b; Tab. 2.4, mean 2011 - 2014) of sludge for use in agriculture

<sup>b</sup> E.g. Re-cultivation, composting

<sup>c</sup> E.g. Building materials, soilification, fermentation

<sup>d</sup> Only sludge from chemical-physical non-public wastewater treatment

<sup>e</sup> Public wastewater treatment: Including amounts sent to drying plant where the subsequent disposal is unknown. Non-public wastewater treatment: E.g. depositing, where still permissible. Including amounts sent to drying plant where the subsequent disposal is unknown.

For the calculation of the N-flows, the uses “Material recycling in landscaping measures” and “Other material recycling” are assigned to the “Material World” sub-pool, which also receives all the N-flows onto settlement areas. The disposal routes “Disposal site”, “Other direct disposal”, “Disposal as hazardous waste” and “Other disposal/unknown” are all assumed to end up as landfill waste.

### 9.2.3 N-discharge into surface waters from settlement wastewater management

Tab. 9-7 shows a summary of the MoRE-results for N-discharge into surface waters from settlement wastewater management. The modelling methods are described in detail in Fuchs et al. (2010) and Fuchs et al. (2017a).

Table 9-7: Nitrogen discharge into surface waters from municipal wastewater treatment plants and sewerage systems (settlement wastewater management) on the basis of MoRE modelling, annual mean for 2010 – 2014 (Fuchs et al. 2016, 2017a).

| <b>N-discharge into surface waters<br/>(Outflow from wastewater treatment plants and sewerage system)</b> | <b>N-species</b> | <b>N-flow<br/>kt N a<sup>-1</sup></b> |
|---|------------------|---------------------------------------|
| N-discharge from municipal wastewater treatment plants  | N(tot)           | 82.2                                  |
| N-discharge via sewerage systems, of which:   |                  | 23.5                                  |
| - Mixed-water overflows   | N(tot)           | 10.4                                  |
| - Discharge from stormwater sewers  | N(tot)           | 8.3                                   |
| - Areas that are only connected to sewers   | N(tot)           | 2.4                                   |
| - Areas with septic tanks   | N(tot)           | 2.4                                   |
| N-discharge from non-public wastewater treatment plants (industrial direct dischargers)                   | N(tot)           | 8.6                                   |
| <b>Total N-discharges from settlement water management</b>  |                  | <b>114.3</b>                          |

#### 9.2.4 Denitrification in municipal and non-public wastewater treatment plants (WS.WW-AT-N2)

Denitrification occurs in the anoxic basins or zones of wastewater treatment plants. Nitrate or nitrite ions act as terminal hydrogen or electron acceptors instead of oxygen. The denitrifying bacteria reduce the oxidised N-compounds (nitrite, nitrate) to molecular nitrogen (N<sub>2</sub>), which escapes into the atmosphere.

No results have been found in the literature on denitrification performance of public wastewater treatment plants. As a rough estimate, a load of 90.8 kt N a is assumed for the outflow from municipal and non-public wastewater treatment plants (see Section 9.2.3, Tab. 9-7; Fuchs et al. 2016). With a mean total-elimination of nitrogen (by denitrification and retention in the sludge) of ~80 % (according to DWA 2017), this gives a load of 454 kt N a<sup>-1</sup> in the inflow of the wastewater treatment plants. Of this, 152.4 kt N a<sup>-1</sup> remains in the sludge (see Tab. 9-6). For the total system of municipal and non-public wastewater treatment plants this gives an estimated N-flow with denitrification of [454 - (90.8 + 152.4)] = 211 kt N a<sup>-1</sup>. The result of 34 % of the nitrogen remaining in the sludge (152.4 kt N a<sup>-1</sup> from 454 kt N a<sup>-1</sup>) is somewhat higher than the 25 % given by DWA (2011) as a rule-of-thumb value.

### 9.3 Summary of N-flows for the “Waste” (WS) pool

Tab. 9-8 shows the N-flows of the “Waste” pool.

Table 9-8: Incoming and outgoing N-flows of sub-pools in the “Waste” pool, annual mean for 2010 – 2014.

| Pool(ex)                              | Pool(in)          | Flow code           | Description  | N-species                             | N-flow<br>kt N a <sup>-1</sup> |
|---------------------------------------|-------------------|---------------------|--|---------------------------------------|--------------------------------|
| <b>Sub-Pool “Solid Waste” (WS.SW)</b> |                   |                     |  |                                       |                                |
| EF.EC                                 | WS.SW             | EF.EC-WS.SW-waste   | Waste from the production of fuels and refinery products   | N(org)                                | 1.6                            |
| MP.FP                                 | WS.SW             | MP.FP-WS.SW-fuel    | Bone meal for thermal recycling  | N(org)                                | 18.8                           |
| MP.OP                                 | WS.SW             | MP.OP-WS.SW-waste   | Waste from Other producing industry  | N(org)                                | 48.4                           |
| HS.HB                                 | WS.SW             | HS.HB-WS.SW-waste   | Domestic waste (food waste)  | N(org)                                | 127.9                          |
| HS.MW                                 | WS.SW             | HS.MW-WS.SW-waste   | Waste from consumer goods  | N(org)                                | 45.9                           |
| WS.WW                                 | WS.SW             | WS.WW-WS.SW-sludge  | Sludge for depositing, disposal as hazardous waste, or other disposal                                  | N(org)                                | 23.9                           |
| WS.WW                                 | WS.SW             | WS.WW-WS.SW-sludge  | Sludge for thermal recycling   | N(org)                                | 72.4                           |
| RW                                    | WS.SW             | RW-WS.SW-waste      | Import of waste materials  | N(org)                                | 9.1                            |
| WS.SW                                 | AT                | WS.SW-AT-gasEM      | NO <sub>x</sub> and N <sub>2</sub> O emissions from waste incineration plants and waste disposal sites | NO <sub>x</sub> ,<br>N <sub>2</sub> O | 0.1<br>0.6                     |
| WS.SW                                 | AT                | WS.SW-AT-gasEM      | NH <sub>3</sub> emissions from waste incineration plants and waste disposal sites                      | NH <sub>3</sub>                       | 2.9                            |
| WS.SW                                 | AT                | WS.SW-AT-N2         | Waste incineration   | N <sub>2</sub>                        | 181.6                          |
| WS.SW                                 | AT                | WS.SW-AT-N2         | Thermal recycling (incineration) of sludge   | N <sub>2</sub>                        | 72.4                           |
| WS.SW                                 | AT                | WS.SW-AT-N2         | Bone meal for thermal recycling  | N <sub>2</sub>                        | 18.8                           |
| WS.SW                                 | MP.OP             | WS.SW-MP.OP-waste   | Recycling of waste materials (material recycling)  | N(org)                                | 349.2                          |
| WS.SW                                 | AG.SM             | WS.SW-AG.SM-compost | Compost (from municipal green waste) for agriculture   | N(org)                                | 23.4                           |
| WS.SW                                 | SINK <sup>a</sup> | WS.SW-SINK-waste    | Depositng waste  | N(org)                                | 61.6                           |
| WS.SW                                 | SINK <sup>a</sup> | WS.WW-SINK-sludge   | Sludge for depositing, disposal as hazardous waste, or other disposal                                  | N(org)                                | 23.9                           |
| WS.SW                                 | RW                | WS.SW-RW-waste      | Export of waste materials  | N(org)                                | 2.8                            |
| <b>Sub-Pool “Wastewater” (WS.WW)</b>  |                   |                     |  |                                       |                                |
| HS.HB                                 | WS.WW             | HS.HB-WS.WW-sewage  | Sewage from households   | N(tot)                                | 350                            |
| HS.MW                                 | WS.WW             | HS.MW-WS.WW-sewage  | Wastewater from settlement areas (sealed areas)  | N(tot)                                | 30.0                           |
| EF.EC                                 | WS.WW             | EF.EC-WS.WW-sewage  | Wastewater from energy conversion  | N(tot)                                | 8.1                            |
| MP.FP                                 | WS.WW             | MP.FP-WS.WW-sewage  | Wastewater from food and feed industry   | N(tot)                                | 36.3                           |
| MP.NC                                 | WS.WW             | MP.FP-WS.WW-sewage  | Wastewater from Nitrogen chemistry   | N(tot)                                | 68.6                           |



| Pool(ex) | Pool(in) | Flow code             | Description  | N-species                             | N-flow<br>kt N a <sup>-1</sup> |
|----------|----------|-----------------------|--|---------------------------------------|--------------------------------|
| MP.OP    | WS.WW    | MP.FP-WS.WW-sewage    | Wastewater from Other producing industry   | N(tot)                                | 21.5                           |
| WS.WW    | AT       | WS.WW-AT-gasEM        | NO <sub>x</sub> and N <sub>2</sub> O emissions from wastewater treatment plants  | NO <sub>x</sub> ,<br>N <sub>2</sub> O | n.r.<br>1.1                    |
| WS.WW    | AT       | WS.WW-AT-N2           | Denitrification in municipal and non-public wastewater treatment plants  | N <sub>2</sub>                        | 211.0                          |
| WS.WW    | HS.MW    | WS.WW-HS.MW-sludge    | Sludge for use in landscaping measures   | N(org)                                | 31.2                           |
| WS.WW    | AG.SM    | WS.WW-AG.SM-sludge    | Sludge for recycling in agriculture  | N(org)                                | 24.9                           |
| WS.WW    | WS.SW    | WS.WW-WS.SW-sludge    | Sludge for depositing, disposal as hazardous waste, or other disposal  | N(org)                                | 23.9                           |
| WS.WW    | WS.SW    | WS.WW-WS.SW-sludge    | Thermal recycling of sludge  | N <sub>2</sub> , NO <sub>x</sub>      | 72.4                           |
| WS.WW    | HY.SW    | WS.WW-HY.SW-discharge | N-discharge into surface waters from wastewater treatment plants and the sewerage system <sup>b</sup> (settlement wastewater management) | N(tot)                                | 114.3                          |

n.r.: not relevant.

<sup>a</sup> On Pool(in) "SINK" see Section 9.4.

<sup>b</sup> N-inflow in discharge from municipal wastewater treatment plants, mixed-water overflows, and stormwater sewers, areas only connected to the sewerage system, areas only connected to septic tanks, and industrial direct dischargers.

## 9.4 Balance and comments for the "Waste" (WS) pool

Determining N-flows for sub-pools "Solid Waste" and "Wastewater" involves a high degree of uncertainty. In view of the completely different data situation and the absence of internal N-flows (apart from sludge), these two sub-pools are dealt with separately (Tables 9-9 and 9-10).

The flow of primary waste materials through the various sorting and treatment stages, the recycling of materials, and final disposal or incineration cannot be traced transparently on the basis of the statistics about waste disposal (DESTATIS 2018). The outputs are classified as "Waste for recycling" or "Waste for disposal" by the plant operator. The Federal Statistical Office has no information about the further treatment of the waste flows, so it is not possible to determine quantities for the individual types of waste or to make statements about material recycling (Federal Statistical Office, written communication, 3 July 2018). For the calculation of plausible N-flows in this sector, the flows must be broken down further to show various material groups to which plausible mean N-contents can then be allocated. The Federal Statistical Office has addressed the shortcomings in the statistics about waste disposal at least in part by developing a waste balance model which claims to provide a better description of the origins and fate of waste materials.

The assumptions made about the N-contents of the individual types of waste are somewhat speculative. As a rule, the values for the N-flows in waste treatment therefore involve very considerable uncertainties. The discrepancy in the case of consumer goods has already been mentioned (see Section 6.4). According to the statistics, 166 kt N a<sup>-1</sup> enters households in consumer goods (MP.OP-HS.MW-prod), but the waste statistics only show a flow of 46 kt N a<sup>-1</sup> from consumer goods to waste (HS.MW-WW.SW-waste). Since there are no appreciable increases in stocks of commodities in the private



households and no other outflow comes into question for consumer goods apart from Waste, these two figures do not “match”. In the current form, Tab. 9-8 for the sub-pool “Solid Waste” therefore functions primarily to list relevant N-flows and occupy this position in the N-flow system of NNB (ECE 2013).

Table 9-9:  $N_r$  inflows and outflows for the “Solid Waste” sub-pool, annual mean for 2010 – 2014; *Italics: N-flow calculated as difference.*

| Inflow                                 | kt N a <sup>-1</sup> | Outflow <sup>a</sup>   | t N a <sup>-1</sup>        |
|--|----------------------|--|----------------------------|
| Waste (including sludge and bone meal) | 338.9                | Material recycling of waste and the use of sludge for landscaping                                  | - 372.6                    |
| Net import                             | 6.3                  | Landfill of waste and sludge   | - 85.5                     |
|  |                      | <i>Reduction of N(org) to N<sub>2</sub> (with the incineration of waste, bone meal and sludge)</i> | - 272.8                    |
| <b>Total inflows</b>                   | <b>345.2</b>         | <b>Total outflows</b>  | <b>- 731.6<sup>b</sup></b> |
| <b>Difference: - 386.4</b>             |                      |  |                            |

<sup>a</sup> N-loads and types of flow see Table 9-3 (WS.SW-XX.XX, N-outflows of the sub-pool “Solid Waste”).

<sup>b</sup> Including 0.7 kt N a<sup>-1</sup> NO<sub>x</sub> and N<sub>2</sub>O emissions from waste incineration plants and waste disposal sites.

Anaerobic processes in landfill sites convert most of the reactive nitrogen in waste into NH<sub>3</sub>, together with traces of organic N-compounds. These nitrogen compounds are transported almost completely in seepage water and only in very small amounts in landfill gas. The NH<sub>3</sub> in landfill gas is typically in the range 10 to 50 mg m<sup>-3</sup>. There are also indications that NH<sub>3</sub> in landfill gas rising through the aerobic surface layers of waste depots can be oxidised biologically to N<sub>2</sub>O, but further details are not available at present (UBA, written communication, 04.07.2018). The seepage water in landfill sites is usually pumped to municipal wastewater treatment plants and is therefore included in the N-flow “Wastewater from industrial direct and indirect dischargers”.

Main N-flows for sub-pool “Wastewater” can only be estimated imprecisely.  $N_r$  in discharges into surface waters from public and non-public wastewater treatment plants can be calculated relatively well on the basis of the quantities and the mean N-concentrations (Section 9.2.3). Good statistics are available for N-quantities in sludge (Section 9.2.2). On the inflow side, in contrast, only rough estimates can be made of the N-quantities in the sewage from households and from industrial indirect and direct dischargers (Section 9.2.1). Overall, a mean value for the total elimination (by denitrification and retention in sludge) can be assumed to be ~80 % for nitrogen in wastewater treatment plants (after DWA 2017). With a different elimination rate, the N-load would differ correspondingly, as would the denitrification (calculated as a difference). The effect would be carried on to the N-outflows from the four sub-pools (EF.EC, MP.FP, MP.NC, MP.OP), to which the industrial direct and indirect dischargers are allocated. The balances for these sub-pools would then also be changed. Tab. 9-10 shows the inflows and outflows for the “Wastewater” sub-pool.

Table 9-10:  $N_r$  inflows and outflows for the sub-pool “Wastewater”, annual mean for 2010 – 2014; *Italics: N-flow calculated as difference.*

| Inflow ( $N_r$ -sources)  | $kt N a^{-1}$ | $N_r$ outflow   | $t N a^{-1}$   |
|---|---------------|---|----------------|
| Wastewater (sewage from households, industrial direct and indirect dischargers, sealed areas) | 514.4         | Discharge into surface waters from wastewater treatment plants and sewerage system  | - 114.3        |
|   |               | Sludge (without incineration)   | - 80.0         |
|   |               | Sludge for thermal disposal (incineration)  | - 72.4         |
|   |               | <i>Denitrification in Wastewater treatment plants</i>                               | - 211.0        |
|   |               | <i>NO<sub>x</sub> and N<sub>2</sub>O emissions from wastewater treatment plants</i> | - 1.1          |
| <b>Total inflows</b>  | <b>514.4</b>  | <b>Total outflows</b>   | <b>- 478.8</b> |
| <b>Difference: 35.6</b>   |               |   |                |

The plausibility of the N-mass balance for public and non-public wastewater treatment in Section 9.2.1, we can refer to the national comparison of the performance of municipal wastewater treatment plants for 2016 (DWA 2017):

|                             |                            |
|-----------------------------|----------------------------|
| Annual volume of wastewater | 8,728 million $m^3 a^{-1}$ |
| Mean population equivalent  | 106.7 million PE           |
| Mean N-concentration        | 50.3 $mg N_{tot} l^{-1}$ . |

For the wastewater treatment plants included in the DWA comparison, this gives a mean population equivalent  $N_{tot}$  load of  $11.3 g d^{-1}$ , which compares quite well with the per capita load of  $12 g d^{-1}$  we use (see Section 9.2.1). Values in the literature for  $N_2O$  emissions from wastewater treatment plants vary widely. For large-scale wastewater treatment plants,  $N_2O$ -load measurements range from 0.003 to 2.6 % of the N-inflow (Parravicini et al. 2015). Measurements for Austrian wastewater treatment plants gave an emissions factor of 0.16 %  $N_2O-N/N_{inflow}$  (median value according to Parravicini et al. 2015). With the N-flow of  $1.1 kt N a^{-1}$  for the  $N_2O$  emissions from wastewater treatment plants as shown in Tab. 9-10 (after the National Inventory Report, NIR, UBA 2016a) and a total inflow of  $484 kt N a^{-1}$  (without outflow from sealed areas), the emissions factor for Germany is 0.23 %  $N_2O-N/N_{inflow}$ , which is somewhat higher than the median of the measurement values from Austria.

Nitrate leaching from landfill sites is not taken into consideration, because if these sites are built and operated in accordance with regulations no water can find its way through to the groundwater.

## 9.5 Uncertainty assessment for the N-flows for “Waste” (WS) pool

Tab. 9-11 gives the uncertainties in the calculation of the N-flows for the “Waste” Pool.

Table 9-11: Uncertainties in the calculation of N-flows for “Waste” pool

| Flow code  | Description   | N-species                           | Uncertainty Quantity structure   | Uncertainty Coefficients   | Level <sup>a</sup> |
|--|---|-------------------------------------|--|--|--------------------|
| <b>Sub-Pool “Solid Waste” (WS.SW)</b>  |   |                                     |  |  |                    |
| EF.EC-WS.SW-waste<br>MP.FP-WS.SW-waste<br>MP.NC-WS.SW-waste<br>MP.OP-WS.SW-waste<br>HS.HB-WS.SW-waste<br>HS.MW-WS.SW-waste<br>RW-WS.SW-waste<br>WS.SW-MP.OP-waste<br>WS.SW-RW--waste | Waste from various sub-pools<br>Recycling of waste<br>Import and export of waste                | N(tot)                              | Medium to high; Material flows in waste management are not clearly distinguished in terms of origin, treatment, and final disposal | High; Some assumptions about N-contents in waste materials are speculative | 4                  |
| WS.WW-WS.SW-sludge   | Sludge for thermal disposal (incineration)  | N(tot)                              | See sub-pool “Wastewater”  |  | 2                  |
| WS.SW-AT-gasEM   | NO <sub>x</sub> , N <sub>2</sub> O emissions Waste incineration plants and waste disposal sites | NO <sub>x</sub><br>N <sub>2</sub> O | See Tab. 3-11  |  | 2 / 4              |
| WS.SW-AG.SM-comp   | Compost for use in agriculture  | N(org)                              | Low  | Low  | 2                  |
| WS.SW-AG.BG-waste  | Organic waste for digestion in biogas plants  | N(org)                              | Low  | Low  | 2                  |
| <b>Sub-Pool “Wastewater” (WS.WW)</b>   |   |                                     |  |  |                    |
| HS.HB-WS.WW-sewage   | Domestic waste water  | N(tot)                              | Low  | Medium   | 3                  |
| HS.MW-WS.WW-sewage   | Wastewater from sealed areas  | N(tot)                              | Medium   | High   | 4                  |
| MP.XX-WS.WW-sewage   | Wastewater from industrial direct and indirect dischargers                                      | N(tot)                              | Medium   | High   | 4                  |
| WS.WW-AT-gasEM   | NO <sub>x</sub> and N <sub>2</sub> O emissions from Wastewater treatment plants                 | NO <sub>x</sub> , N <sub>2</sub> O  | see Tab. 3-11  |  | 2 / 4              |

| Flow code  | Description   | N-species | Uncertainty Quantity structure   | Uncertainty Coefficients | Level <sup>a</sup> |
|--|---|-----------|--|--------------------------|--------------------|
| WS.WW-AT-N2  | Denitrification in municipal and non-public wastewater treatment plants                       | N2        | High; calculated as a difference   |                          | 4                  |
| WS.WW-HS.MW-sludge<br>WS.WW-AG.SM-sludge<br>WS.WW-WS.SW-sludge | Sludge -<br>All forms of use or recycling   | N(org)    | Very low (see DESTATIS 2014: Survey of public wastewater – Quality report) | Low                      | 2                  |
| WS.WW-HY.SW-discharge  | N(tot) discharge into surface waters from wastewater treatment plants and the sewerage system | N(tot)    | Low  | Low                      | 2                  |

<sup>a</sup> Level of uncertainty in accordance with Tab. 2-3.

## 10 Hydrosphere (HY)

The “Hydrosphere” pool includes inflows and transport of nitrogen in inorganic and organic forms in the hydrosphere; Tab. 10-1 gives an overview of the relevant nitrogen flows. There are three sub-pools:

- ▶ Groundwater (HY.GW)
- ▶ Surface Waters (HY.SW)
- ▶ Coastal Waters (HY.CW).

In contrast to the other pools (with the exception of “Atmosphere” pool) all key N-flows in the “Hydrosphere” pool are modelled using MoRE (Modelling Regionalized Emissions; Fuchs et al. 2017a, 2017b), which estimates the inputs of materials (e.g. nutrients, heavy metals) into surface waters via various pathways. The approach was developed by Behrendt et al. (1999). MoRE distinguishes between point sources (municipal wastewater treatment plants, industrial direct dischargers) and diffuse sources and other processes (erosion, runoff, drainage, atmospheric depositions, stormwater sewers, mixed wastewater overflows, groundwater, and cess pits). The complex modelling approaches require a wide range of general and material-specific data with which the inputs into the Hydrosphere can be determined on an annual basis according to entry pathway and analysis areas. In general, input data is used which is available uniformly for all of Germany. For our applications, mean annual figures were calculated from the data for the period 2010-2014. MoRE uses hierarchical spatial resolutions. The basic units are 2759 spatial analysis units (mean size 130 km<sup>2</sup>), determined on the basis of hydrological and administrative criteria (Fuchs et al. 2010). The aggregate of the results corresponds to the total for Germany.

Measurements of water flows from surface waters, soils and groundwater and of the concentrations of N-compounds in waters therefore only included indirectly in the following results. Firstly, the measurements are used for calibration and validation of the MoRE model. Secondly, the modelled annual N-loads in running waters are adjusted using the measured outflow volumes.

Table 10-1: Incoming and outgoing N-flows for the “Hydrosphere” sub-pools <sup>a</sup>.

| Pool(ex)                              | Pool(in) | Flow code         | Description  | N-species       | Chapter |
|---------------------------------------|----------|-------------------|--|-----------------|---------|
| <b>Sub-Pool “Groundwater” (HY.GW)</b> |          |                   |  |                 |         |
| HS.MW                                 | HY.GW    | AG.MW-HY.GW-leach | Nitrate leaching from settlements and the transport infrastructure                 | NO <sub>3</sub> | 10.1.1  |
| AG.SM                                 | HY.GW    | AG.SM-HY.GW-leach | Nitrate leaching from agricultural areas   | NO <sub>3</sub> | 7.2.4   |
| FS.FO                                 | HY.GW    | FS.FO-HY.GW-leach | Nitrate leaching from forest areas   | NO <sub>3</sub> | 8.1.4   |
| FS.OL                                 | HY.GW    | FS.OL-HY.GW-leach | Nitrate leaching from Other land   | NO <sub>3</sub> | 8.2.3   |
| HY.GW                                 | AT       | HY.GW-AT-N2       | Denitrification in the unsaturated zone and in groundwater                         | N <sub>2</sub>  | 10.1.2  |
| HY.GW                                 | HS.HB    | HY.GW-AG.SM-abstr | NO <sub>3</sub> <sup>-</sup> in groundwater abstracted for drinking water supplies | NO <sub>3</sub> | 10.1.2  |
| HY.GW                                 | AG.SM    | HY.GW-AG.SM-irrig | NO <sub>3</sub> <sup>-</sup> in groundwater used for irrigation                    | NO <sub>3</sub> | 7.2.2   |
| HY.GW                                 | HY.SW    | HY.GW-HY.SW-      | NO <sub>3</sub> <sup>-</sup> in groundwater flowing into surface waters            | NO <sub>3</sub> | 10.1.2  |

| Pool(ex)                                  | Pool(in) | Flow code             | Description  | N-species                                   | Chapter |
|---|----------|-----------------------|--|---|---------|
| <b>Sub-Pools “Surface Waters” (HY.SW)</b> |          |                       |  |   |         |
| AT  | HY.SW    | AT-HY.SW-atmDep       | Atmospheric N-deposition on surface waters                                     | NHy, NOx                                    | 3.2.1   |
| AG.SM                                     | HY.SW    | AG.SM-HY.SW-runoff    | NO <sub>3</sub> <sup>-</sup> flows into surface waters from agricultural areas | NO <sub>3</sub><br>N(org)                   | 10.2.1  |
| WS.WW                                     | HY.SW    | WS.WW-HY.SW-sewage    | N flows into surface waters from settlement wastewater management              | NH <sub>3</sub> , NO <sub>3</sub><br>N(org) | 9.2.3   |
| HY.GW                                     | HY.SW    | HY.GW-HY.SW-          | NO <sub>3</sub> <sup>-</sup> in groundwater flowing into surface waters        | NO <sub>3</sub>                             | 10.1.2  |
| RW  | HY.SW    | RW-HY.SW-discharge    | N(tot)-load in trans-boundary inflow (from up-stream neighbouring countries)   | NO <sub>3</sub> ,<br>N(tot)                 | 10.2.3  |
| HY.SW                                     | AT       | HY.SW-AT-N2           | Denitrification (retention) in surface waters                                  | N <sub>2</sub>                              | 10.2.2  |
| HY.SW                                     | RW       | HY.SW-RW-discharge    | N(tot)-load in trans-boundary outflow (to down-stream neighbouring countries)  | NO <sub>3</sub> ,<br>N(tot)                 | 10.2.3  |
| HY.SW                                     | MP.FP    | HY.SW-MP.FP-fish      | Inland fisheries   | N(org)                                      | 7.1.2   |
| <b>Sub-Pool “Coastal Waters” (HY.CW)</b>  |          |                       |  |   |         |
| AT  | HY.CW    | AT-HY.CW-atmDep       | Atmospheric N-deposition on coastal waters                                     | NHy, NOx                                    | 3.2.1   |
| HY.SW                                     | HY.CW    | HY.SW-HY.CW-discharge | N(tot)-load in inflow into coastal seas  | NO <sub>3</sub> ,<br>N(org)                 | 10.2.3  |
| HY.CW                                     | MP.FP    | HY.CW-MP.FP-fish      | Sea fishing (landings)   | N(org)                                      | 10.2.4  |

<sup>a</sup> N-Retention in coastal waters is not included.

**Note:** The transport of sediment particles containing nitrogen into waters or the retention in the benthic zone is not considered in MoRE because the data are inadequate. We do not consider the import/export of nitrogen between the coastal seas (as system boundary for the national nitrogen budget) and the open seas, because as a rule these N-flows are not relevant for the evaluation of the national N<sub>r</sub> balance. The production of fish in aquaculture is included under the “Animal Husbandry” sub-pool of the “Agriculture” pool.

## 10.1 Sub-pool “Groundwater” (HY.GW)

### 10.1.1 Nitrate leaching (AG.XX-HY.GW-leach, FS.XX-HY.GW-leach)

In the MoRE model, nitrate leaching is only considered for agriculture. As a simplification, the nitrate load in groundwater is modelled as the N<sub>r</sub> flow from the agricultural area minus the gaseous N<sub>r</sub> emissions (NH<sub>3</sub>, NO<sub>x</sub>, N<sub>2</sub>O) totalling 1113.2 kt N a<sup>-1</sup>, and this value is taken as (potential) nitrate leaching. The reduction of the N-load (as a result of denitrification in the root zone, in the unsaturated zone and in aquifers) is not compartmentalised in the MoRE model (see Section 10.1.2; cf. Fuchs et al. 2017a).

For the national nitrogen budget, the total of 1113.2 kt N a<sup>-1</sup> is made up of 121.9 kt N a<sup>-1</sup> lateral NO<sub>3</sub><sup>-</sup> inflow into surface waters, 233.9 kt N a<sup>-1</sup> denitrification in the root zone of agricultural soils, and 757.1 kt N (as a difference quantity) which is attributed to nitrate leaching from agricultural areas *below* the root zone and which is an inflow for the “Hydrosphere” pool (see Tab. 7-6). With a mean percolation

rate of 220 mm a<sup>-1</sup> on agricultural areas in Germany, this gives a mean nitrate concentration in leachate (below the root zone) of ~90 mg NO<sub>3</sub><sup>-</sup> l<sup>-1</sup>.

Nitrate leaching from settlements and the transport infrastructure (unsealed urban areas) is equated to the atmospheric NO<sub>x</sub> and NH<sub>y</sub> deposition rate totalling 18 kg N ha<sup>-1</sup> a<sup>-1</sup> (Tab. 3-6) plus the surface potential of roads (from falling leaves, animal excrement, etc.) of 4 kg N ha<sup>-1</sup> a<sup>-1</sup> (after Behrendt et al. 1999). For total unsealed urban areas of 16,372 km<sup>2</sup> (EEA 2014, 2016), the nitrogen leaching is therefore 36.0 kt N a<sup>-1</sup>. Percolation rate on unsealed urban areas is ~148 mm a<sup>-1</sup>, so that the mean nitrate concentration in the leachate from unsealed urban areas is about 66 mg NO<sub>3</sub><sup>-</sup> l<sup>-1</sup>.

For the nitrate leaching from forest areas and other land, the estimates from Sections 8.1.4 and 8.2.3 are used (but not including nitrate leaching from Wetland).

Nitrate leaching from settlements and the transport infrastructure, and from forests and other land is not reduced to allow for denitrification in the root zone. For these uses, the leaching below the root zone is estimated as an independent quantity or determined from measurements.

Table 10-2: Nitrate leaching in the sub-pool “Groundwater”.

| Pool(ex)                                       | Pool(in) | Flow code         | Description  | N-species | N-flow kt N a <sup>-1</sup> |
|--|----------|-------------------|--|-----------|-----------------------------|
| HS.MW  | HY.GW    | AG.MW-HY.GW-leach | Nitrate leaching from settlements and the transport infrastructure | NO3       | 36.0                        |
| AG.SM  | HY.GW    | AG.SM-HY.GW-leach | Nitrate leaching from agricultural areas (below the root zone)     | NO3       | 757.1                       |
| FS.FO  | HY.GW    | FS.FO-HY.GW-leach | Nitrate leaching from forest areas                                 | NO3       | 60.8                        |
| FS.OL  | HY.GW    | FS.OL-HY.GW-leach | Nitrate leaching from Other land                                   | NO3       | 3.3                         |
| <b>Total nitrate leaching into groundwater</b> |          |                   |  |           | <b>857.2</b>                |

Note that the land use categories in the MoRE model and the areas used for the various land use classes (in particular the agricultural areas) differ from those in Tab. 3-2, which among other things form the basis for calculating atmospheric depositions. However, these differences do not affect the interpretation and the further use of the results.

### 10.1.2 N-flows from groundwater (HY.GW-AT-N2, HY.GW-AG.SM-abstr, HY.GW-AG.SM-irrig, HY.GW-HY.SW-discharge)

The nitrogen discharge into surface waters from groundwater (HY.GW-HY.SW-discharge) is calculated in the MoRE model from the nitrogen concentrations in the groundwater and the groundwater outflow. Both quantities are determined for the 2759 analysis areas (cf. Fuchs et al. 2010, 2016, 2017a). To model the N-concentration in the groundwater, MoRE uses the N-inputs from agricultural areas, forest areas, and other land. For the estimates here an additional N-input of 3.9 kt N a<sup>-1</sup> is included from unsealed urban areas (assuming a nitrogen concentration of 1 mg N l<sup>-1</sup> in groundwater under unsealed urban areas). In MoRE, the nitrogen retention – mainly due to denitrification - in the unsaturated zone (below the root zone) and in groundwater is estimated for the agricultural areas using an empirically derived equation which takes into account the leaching rate and the hydrogeological site conditions (5-level classification); for details see Fuchs et al (2010). Using this approach, the model gives an NO<sub>3</sub><sup>-</sup> input of 268.2 kt N a<sup>-1</sup> into surface waters from groundwater outflow.

In order to calculate the nitrate in groundwater abstracted for drinking water, the annual abstraction rate is set at 2,725 million m<sup>3</sup> a<sup>-1</sup> (DESTATIS, 2015c). As a simplification, for the estimation of this N-flow (HY.GW-AG.SM-abstr) a mean concentration is used of 25 mg NO<sub>3</sub> l<sup>-1</sup> or 5.6 mg N l<sup>-1</sup>. The nitrate in groundwater extracted for field irrigation in agriculture (HY.GW-AG.SM-irrig) is discussed in Section 7.2.2. The N-outflows from groundwater are summarised in Tab. 10-3.

With an inflow into sub-pool “Groundwater” of 857.2 kt N a<sup>-1</sup> (Tab. 10-2), N-outflow with the abstraction of groundwater for drinking water and irrigation water of 17.0 kt N a<sup>-1</sup> (Tab. 10-3) and the N-flow of groundwater into surface waters of 268.2 kt N a<sup>-1</sup>, then the difference of 572 kt N a<sup>-1</sup> can be accounted for by denitrification in the unsaturated zone and in groundwater. This approach involves the assumption that the amount of nitrogen in the groundwater is constant over time, i.e. that NO<sub>3</sub><sup>-</sup> inflow with leachate, denitrification, and NO<sub>3</sub><sup>-</sup> outflow into surface waters are in dynamic equilibrium, so that there is no change in the NO<sub>3</sub><sup>-</sup> stock in the aquifers.

Table 10-3: Nitrogen discharge from the sub-pool “Groundwater”.

| Pool(ex) | Pool(in) | Flow code             | Description  | N-species | N-flow<br>kt N a <sup>-1</sup> |
|----------|----------|-----------------------|--|-----------|--------------------------------|
| HY.GW    | AT       | HY.GW-AT-N2           | Denitrification in the unsaturated zone and in groundwater                                 | N2        | 572.0                          |
| HY.GW    | HS.HB    | HY.GW-AG.SM-abstr     | NO <sub>3</sub> <sup>-</sup> in groundwater abstracted for drinking water                  | NO3       | 15.4                           |
| HY.GW    | AG.SM    | HY.GW-AG.SM-irrig     | NO <sub>3</sub> <sup>-</sup> in groundwater abstracted as irrigation water for agriculture | NO3       | 1.6                            |
| HY.GW    | HY.SW    | HY.GW-HY.SW-discharge | NO <sub>3</sub> <sup>-</sup> in groundwater discharged into surface waters                 | NO3       | 268.2                          |

## 10.2 Sub-pools “Surface Waters” (HY.SW) and “Coastal Waters” (HY.CW)

Due to the small number of separate N-flows in the “Coastal Water” sub-pool and the close links with the “Surface Waters” sub-pool, the two sub-pools are considered together.

### 10.2.1 Run-off from agricultural areas into surface waters (AG.SM-HY.SW-runoff)

Nitrogen enters surface waters from the “Agriculture” pool with runoff, soil erosion, and drainage. The three paths are modelled separately in MoRE. Tab. 10-4 shows the results. For the presentation of the N-flows, the three paths are combined as the N-inflow with lateral transport.

Table 10-4: Nitrogen flows into surface waters from the “Agriculture” pool by lateral transport according to MoRE-modelling, annual mean for 2010 – 2014.

| Flow code          | Description | N-species | N-flow<br>kt N a <sup>-1</sup> |
|--------------------|-------------|-----------|--------------------------------|
| AG.SM-HY.SW-runoff | Runoff      | NO3       | 29.7                           |
|                    | Erosion     | NO3       | 9.9                            |
|                    |             | N(org)    | 8.2                            |
|                    | Drainage    | NO3       | 74.1                           |
| <b>Total</b>       |             |           | <b>121.9</b>                   |



### 10.2.2 Denitrification in surface waters and coastal waters (HY.SW-AT-N2, HY.CW-AT-N2)

Various transformation, retention and loss processes in surface waters (e.g. nitrification, denitrification, uptake by plants, sedimentation) reduce the amount of reactive nitrogen flowing into the hydrosphere. As a simplification, they are referred to here collectively under denitrification, because this is the dominant process. The denitrification of nitrogen in surface waters is determined as the difference between the total N-flows into the river basins according to the MoRE estimate of 576.5 kt N a<sup>-1</sup> (see Tab. 10-6) minus the N-load in the outflow from Germany into downstream neighbours and coastal seas of 500.6 kt N a<sup>-1</sup> (see Tab. 10-5) giving a result of 75.9 kt N a<sup>-1</sup>.

No plausible data are available from which to estimate denitrification in the coastal seas, and this N-flow is not considered further here.

### 10.2.3 Trans-boundary inflows and outflows (RW-HY.SW-discharge, HY.SW-RW-discharge)

The N(tot) loads in trans-boundary inflow in running waters from upstream neighbours, transboundary outflow to downstream neighbours, and from the river mouths or estuaries into the North Sea and Baltic Sea were determined for the larger rivers (Rhine, Danube, Elbe, Weser) using the measured outflows and substance concentrations (Tab. 10-5). Outflow data is available for the Laender (collected by the German Federal Institute of Hydrology (BfG)) together with outflow data of the Federal Waterways and Shipping Administration (also available from BfG). The data from quality measurement points consists of the data from the LAWA Water Working Group measurement network (collected annually by UBA) and from selected Laender measuring stations. The BfG method was used to calculate the loads using the measurement data (BfG 2013). A correction factor was included to allow for the different positions of the outflow water gauges and quality measuring points. The results are presented in Table 10-5.

Table 10-5: N-load in the trans-boundary inflow and outflow of surface waters, mean 2010 – 2014.

| River basin  | Upstream source or measuring station /River mouth or downstream measuring station | N(tot) in inflow <sup>a</sup> to Germany<br>kt N a <sup>-1</sup> | N(tot) in outflow <sup>b</sup>                  |   |
|--------------|---|--|---|---|
|              |   |  | To downstream neighbour<br>kt N a <sup>-1</sup> | In North Sea and Baltic Sea<br>kt N a <sup>-1</sup> |
| Donau        | DE / Black Sea (Jochenstein)  |  | 99.5  |   |
| Eider        | DE / North Sea  |  |   | 4.9   |
| Elbe         | Schmilka (CZ) / North Sea (Seemannshöft)  | 54.8   |   | 115.0   |
| Ems          | DE / North Sea  |  |   | 14.5  |
| Maas         | DE / NL   |  | 4.1   |   |
| Oder         | Poland / Baltic Sea   |  |   | 5.0 <sup>c</sup>                                    |
| Rhine        | Öhringer (CH) / Kleve-Bimmen (NL)   | 12.5   | 209.7   |   |
| Schlei/Trave | DE / Baltic Sea   |  |   | 6.3   |
| Warnow/Peene | DE / Baltic Sea   |  |   | 14.3  |
| Weser        | DE/ North Sea (Bremen)  |  |   | 27.2  |
| <b>Total</b> |   | <b>67.3</b>  | <b>313.4</b>                                    | <b>187.2</b>  |

<sup>a</sup> N(tot)-load in the trans-boundary inflow (from upstream neighbours).

<sup>b</sup> N(tot)-load in the trans-boundary outflow (to downstream neighbours or into the North Sea or Baltic Sea).

<sup>c</sup> For the River Oder separating Poland and Germany a different approach had to be adopted to calculate the load transported from federal territories.

For the catchments of smaller rivers in coastal areas which flow directly into the North Sea or Baltic Sea, area-specific N-loads were calculated on the basis of an assumed load of 1 kt N km<sup>-2</sup> a<sup>-1</sup> (derived on the basis of the observed loads for selected quality measurement stations of the river basin districts of the Danube, Elbe, Rhine and Weser).

Comparing the N-load in the inflows from upstream neighbours (67.3 kt N a<sup>-1</sup>) and in the outflow from Germany into the coastal seas or to downstream neighbouring countries (combined 500.6 kt N a<sup>-1</sup>), the increase in N(tot)-load in surface waters in their passage through Germany is 433.3 kt N a<sup>-1</sup>. The N(tot) inflows directly into the North Sea and Baltic Sea from German territory in rivers (measured loads) and from coastal areas (modelled N-loads) total 187.2 kt N a<sup>-1</sup>.

#### 10.2.4 Sea fishing (HY.CW-MP.FP-fish)

In the Annual Statistics on Food, Agriculture and Forests (BMEL 2018; Tab. 281), the annual mean for German landings from coastal and deep-sea fishing (2010-2014) were:

Coastal and deep-sea fishing: 226,560 t round weight x 2.8 % N (ECE 2013, Annex 6, Table 12) = 6.3 kt N a<sup>-1</sup>.

### 10.3 Summary of N-flows for the “Hydrosphere” (HY) pool

Tab. 10-6 gives a summary of the N-flows for the “Hydrosphere” pool.

Table 10-6: Incoming and outgoing N-flows for the sub-pools of the “Hydrosphere” pool; annual mean for 2010 – 2014.

| Pool(ex)                                 | Pool(in) | Flow code         | Description  | N-species              | N-flow<br>kt N a <sup>-1</sup> |
|--|----------|-------------------|--|------------------------|--------------------------------|
| <b>Sub-Pool “Groundwater” (HY.GW)</b>    |          |                   |  |                        |                                |
| HS.MW                                    | HY.GW    | AG.MW-HY.GW-leach | Nitrate leaching from settlements and the transport infrastructure                 | NO <sub>3</sub>        | 36.0                           |
| AG.SM                                    | HY.GW    | AG.SM-HY.GW-leach | Nitrate leaching from agricultural areas   | NO <sub>3</sub>        | 757.1                          |
| FS.FO                                    | HY.GW    | FS.FO-HY.GW-leach | Nitrate leaching from forest areas   | NO <sub>3</sub>        | 60.8                           |
| FS.WL                                    | HY.GW    | FS.WL-HY.GW-leach | Nitrate leaching from Other land   | NO <sub>3</sub>        | 3.3                            |
| HY.GW                                    | AT       | HY.GW-AT-N2       | Denitrification in the unsaturated zone and in groundwater                         | N <sub>2</sub>         | 572.0                          |
| HY.GW                                    | HS.HB    | HY.GW-AG.SM-abstr | NO <sub>3</sub> <sup>-</sup> in groundwater abstracted for drinking water          | NO <sub>3</sub>        | 15.4                           |
| HY.GW                                    | AG.SM    | HY.GW-AG.SM-irrig | NO <sub>3</sub> <sup>-</sup> in groundwater abstracted for agricultural irrigation | NO <sub>3</sub>        | 1.6                            |
| HY.GW                                    | HY.SW    | HY.GW-HY.SW-      | NO <sub>3</sub> <sup>-</sup> in groundwater flows into surface waters              | NO <sub>3</sub>        | 268.2                          |
| <b>Sub-Pool “Surface Waters” (HY.SW)</b> |          |                   |  |                        |                                |
| AT                                       | HY.SW    | AT-HY.SW-atmDep   | Atmospheric N-deposition on surface waters   | NHy<br>NO <sub>x</sub> | 3.3<br>1.5                     |

| Pool(ex)                                 | Pool(in) | Flow code             | Description  | N-species                 | N-flow<br>kt N a <sup>-1</sup> |
|--|----------|-----------------------|--|---------------------------|--------------------------------|
| AG.SM                                    | HY.SW    | AG.SM-HY.SW-runoff    | N inflow into surface waters due to runoff, erosion and drainage from agricultural areas | NO <sub>3</sub><br>N(org) | 113.7<br>8.2                   |
| WS.WW                                    | HY.SW    | WS.WW-HY.SW-sewage    | N(tot)-inflow into surface waters from settlement water management                       | N(tot)                    | 114.3                          |
| HY.GW                                    | HY.SW    | HY.GW-HY.SW-          | NO <sub>3</sub> <sup>-</sup> in groundwater flows into surface waters                    | NO <sub>3</sub>           | 268.2                          |
| RW                                       | HY.SW    | RW-HY.SW-discharge    | N(tot)-load in trans-boundary inflow (from upstream neighbours)                          | N(tot)                    | 67.3                           |
| HY.SW                                    | AT       | HY.SW-AT-N2           | Denitrification in surface waters  | N <sub>2</sub>            | 75.9                           |
| HY.SW                                    | RW       | HY.SW-RW-discharge    | N(tot)-load in trans-boundary outflow (to downstream neighbours)                         | N(tot)                    | 313.4                          |
| HY.SW                                    | HY.CW    | HY.SW-HY.CW-discharge | N(tot)-load in the outflow into coastal seas   | N(tot)                    | 187.2                          |
| <b>Sub-Pool “Coastal Waters” (HY.CW)</b> |          |                       |  |                           |                                |
| AT                                       | HY.CW    | AT-HY.CW-atmDep       | Atmospheric N-deposition on coastal waters   | NHy<br>NO <sub>x</sub>    | 1.3<br>0.6                     |
| HY.SW                                    | HY.CW    | HY.SW-HY.CW-discharge | N(tot)-load in inflow to the coastal seas  | N(tot)                    | 187.2                          |
| HY.CW                                    | MP.FP    | HY.CW-MP.FP-fish      | Sea fishing (landings)   | N(org)                    | 6.3                            |

#### 10.4 Balance and comments for the “Hydrosphere” (HY) pool

Tab. 10-7 shows inflows and outflows for the pool “Hydrosphere”. The difference of some 182.8 kt N a<sup>-1</sup> is nearly identical with the N-load of 187 kt N a<sup>-1</sup> discharged into the North Sea and Baltic Sea. This N-flow is not treated as an export in the NNB system, because the coastal seas are included under national territories. For future nitrogen budgets it is recommended that the system boundary should be the limnic/marine transition points, analogous to the boundary transition points for the flows to downstream neighbouring countries.

The denitrification is calculated as a difference value under the premise that the nitrogen amount of in the groundwater in Germany is constant over time (see Section 10.1.2). This necessarily results in a (near) balanced budget for the “Hydrosphere” pool (not including the coastal seas). In view of the inadequate knowledge about the actual denitrification rates in the root zone (of agricultural areas), in the unsaturated zone, in the aquifers, and in the surface waters, the figures in Tab. 10-7 should not be interpreted as estimates reflecting the real situation, but rather as indicators of the level of denitrification that would be necessary to reduce N<sub>r</sub> to molecular N<sub>2</sub> in order to avoid an increase of N<sub>r</sub> in the hydrosphere (mainly in the form of NO<sub>3</sub><sup>-</sup>).

Table 10-7: Nitrogen inflows and outflows for the “Hydrosphere” pool, annual mean for 2010 – 2014; *italics: estimate or difference between N-flows.*

| Inflow (N <sub>r</sub> -sources)   | kt N a <sup>-1</sup> | Outflow (N <sub>r</sub> -use)                                     | t N a <sup>-1</sup> |
|--|----------------------|---|---------------------|
| Atmospheric deposition   | 6.7                  | NO <sub>3</sub> <sup>-</sup> removed with water extraction        | 17.0                |
| NO <sub>3</sub> <sup>-</sup> inflow from agricultural areas <sup>a</sup> | 121.9                | <i>Denitrification in the unsaturated zone and in groundwater</i> | <i>572.0</i>        |
| Inflow from wastewater treatment plants and the sewerage system          | 114.3                | <i>Denitrification (retention) in surface waters</i>              | <i>75.9</i>         |
| <i>Nitrate leaching (below the root zone)</i>                            | <i>857.2</i>         | Sea fishing   | 6.3                 |
| Load in the flow from upstream neighbouring countries                    | 67.3                 | Load in the flow to downstream neighbouring countries             | 313.4               |
| <b>Total inflows</b>   | <b>1167.4</b>        | <b>Total outflows</b>   | <b>- 984.6</b>      |
| <b>Difference: 182.8</b>   |                      |   |                     |

<sup>a</sup> By runoff, erosion and drainage flows.

### 10.5 Uncertainty assessment for the N-flows of “Hydrosphere” (HY) pool

Tab. 10-8 shows the uncertainties in the calculation of the N-flows for the “Hydrosphere” pool.

Table 10-8: Uncertainties in the calculation of the largest N-flows for the “Hydrosphere” pool.

| Flow code                                | Description  | N-species     | Uncertainty Quantity structure  | Uncertainty Coefficients  | Level <sup>a</sup> |
|--|--|---------------|---|---|--------------------|
| <b>Sub-Pool “Groundwater” (HY.GW)</b>    |  |               |   |   |                    |
| HS.MW-HY.GW-leach                        | Nitrate leaching from settlements and transport infrastructure                   | NO3           | High; NO <sub>3</sub> <sup>-</sup> load in leachate: Value estimated                              |   | 4                  |
| AG.SM-HY.GW-leach                        | Nitrate leaching from Agricultural areas   | NO3           | Groundwater replenishment rates from Agricultural areas: medium                                   | NO <sub>3</sub> <sup>-</sup> concentration in leachate: MoRE Model calculation: high                | 4                  |
| FS.FO-HY.GW-leach                        | Nitrate leaching from forest areas   | NO3           | see Tab. 8-9  |   | 4                  |
| FS.WL-HY.GW-leach                        | Nitrate leaching from Other land   | NO3           | High; NO <sub>3</sub> <sup>-</sup> load in leachate: Value estimated                              |   | 4                  |
| HY.GW-AT-N2                              | Denitrification in the unsaturated zone and in Groundwater                       | N2            | High; calculated as the difference between highly uncertain values                                |   | 4                  |
| HY.GW-AG.SM-abstr                        | NO <sub>3</sub> <sup>-</sup> in groundwater abstracted for drinking water        | NO3           | Low   | Medium; NO <sub>3</sub> <sup>-</sup> concentration in abstracted water estimated                    | 3                  |
| HY.GW-HY.SW-leach                        | NO <sub>3</sub> <sup>-</sup> inflow into surface waters with groundwater outflow | NO3           | Groundwater outflow: Medium   | NO <sub>3</sub> <sup>-</sup> concentration in groundwater outflow: MoRE Model calculation: high     | 4                  |
| <b>Sub-Pool “Surface Waters” (HY.SW)</b> |  |               |   |   |                    |
| AT-HY.SW-atmDep                          | Atmospheric N-deposition on surface waters                                       | NHy<br>NOx    | see Tab. 3-11   |   | 3                  |
| AG.SM-HY.SW-runoff                       | NO <sub>3</sub> <sup>-</sup> inflow into surface waters from Agricultural areas  | NO3<br>N(tot) | NO <sub>3</sub> <sup>-</sup> loads for runoff, erosion and drainage: MoRE Model calculation: high |   | 4                  |
| WS.WW-HY.SW-sewage                       | N(tot)- discharge into surface waters from settlement water management           | N(tot)        | Discharge amounts: medium (Evaluation of wastewater treatment plant registers)                    | N-concentrations in discharge: medium (Evaluation Wastewater treatment plants, self-monitoring)     | 3                  |
| HY.GW-HY.SW-                             | NO <sub>3</sub> <sup>-</sup> inflow into surface waters with groundwater outflow | NO3           | Groundwater outflow rates: medium   | NO <sub>3</sub> <sup>-</sup> concentration in the groundwater-outflow: MoRE Model calculation: high | 4                  |

| Flow code                                | Description  | N-species  | Uncertainty Quantity structure   | Uncertainty Coefficients                                   | Level <sup>a</sup> |
|--|--|------------|--|--|--------------------|
| RW-HY.SW-discharge                       | N(tot)-load in trans-boundary inflow (from upstream neighbours)  | N(tot)     | Flow measurements: Low   | N-concentration in the outflow: Low (for the larger flows) | 2                  |
| HY.SW-AT-N2                              | Denitrification in surface waters                                | N2         | High; calculated as the difference between uncertain values                          |  | 4                  |
| HY.SW-RW-discharge                       | N(tot)-load in trans-boundary outflow (to downstream neighbours) | N(tot)     | Flow measurements: Low   | N-concentration in the outflow: Low (for the larger flows) | 2                  |
| <b>Sub-Pool "Coastal Waters" (HY.CW)</b> |  |            |  |  |                    |
| AT-HY.CW-atmDep                          | Atmospheric N-deposition on coastal waters                       | NHy<br>NOx | see Tab. 3-11  |  | 3                  |
| HY.SW-HY.CW-discharge                    | N(tot)-load in discharge into coastal seas                       | N(tot)     | Flow measurements: Low;<br>For small rivers without flow measurements: Model results | N-concentration in outflow: Low (for the larger flows)     | 2                  |
| HY.CW-MP.FP-fish                         | Sea fishing (landings)   | N(org)     | Very low   | Very low   | 1                  |

<sup>a</sup> Level of uncertainty in accordance with Tab. 2-3.

## 11 Trans-boundary N-flows (RW)

Trans-boundary N-flows consist of the  $N_r$  imports to Germany and  $N_r$  exports from Germany. These are determined individually for each pool. Tables 11-1 and 11-2 show the summarised results.

Table 11-1: Imports and exports (incoming and outgoing N-flows) in the “Trans-boundary N-flows” pool, annual mean for 2010 – 2014.

| Pool(ex)             | Pool(in) | Flow code          | Description <sup>a</sup>                     | Section | N-species          | N-flow<br>kt N a <sup>-1</sup> |
|----------------------|----------|--------------------|--|---------|--------------------|--------------------------------|
| RW                   | AT       | RW-AT-gasN         | Atmospheric transport of gaseous N-compounds | 3.5     | NHy<br>NOx         | 103.7<br>114.7                 |
| RW                   | EF.EC    | RW-EF.EC-fuel      | Import of fuels                              | 4.1.1   | N(org)             | 1735.0                         |
| RW                   | MP.FP    | RW-MP.FP-food      | Food industry imports <sup>a</sup>           | 5.1.6   | N(org)             | 890.0                          |
| RW                   | MP.NC    | RW-MP.NC-prod      | Import of nitrogenous chemical products      | 5.2.4   | NH3,NO3,<br>N(org) | 2262.2                         |
| RW                   | MP.OP    | RW-MP.OP-prod      | Imports consumer goods industry              | 5.3     | N(org)             | 311.4                          |
| RW                   | AG.SM    | RW-AG.SM-manure    | Imports of manure <sup>a</sup>               | 7.2.1   | N(org)             | 14.3                           |
| RW                   | FS.FO    | RW-FS.FO-wood      | Import von round wood                        | 8.1.5   | N(org)             | 4.3                            |
| RW                   | WS.SW    | RW-WS.SW-waste     | Import of waste materials                    | 9.1.3   | N(org)             | 9.1                            |
| RW                   | HY.SW    | RW-HY.SW-discharge | N load in trans-boundary inflows             | 10.2.3  | NO3,<br>N(org)     | 67.3                           |
| <b>Total Imports</b> |          |                    |  |         |                    | <b>5512.0</b>                  |
| AT                   | RW       | AT-RW-gasN         | Atmospheric transport of gaseous N-compounds | 3.5     | NHy<br>NOx         | 248.8<br>280.5                 |
| EF.EC                | RW       | EF.EC-RW-fuel      | Export of fuels and mineral oil products     | 4.1.1   | N(org)             | 62.7                           |
| MP.FP                | RW       | MP.FP-RW-food      | Food industry exports <sup>a</sup>           | 5.1.6   | N(org)             | 635.2                          |
| MP.NC                | RW       | MP.NC-RW-prod      | Export nitrogenous chemical products         | 5.2.4   | NH3,NO3,<br>N(org) | 1797.1                         |
| MP.OP                | RW       | MP.OP-RW-prod      | Export consumer goods industry               | 5.3     | N(org)             | 308.9                          |
| FS.FO                | RW       | FS.FO-RW-wood      | Exports of round wood                        | 8.1.5   | N(org)             | 2.2                            |
| WS.SW                | RW       | WS.SW-RW-waste     | Exports of waste materials                   | 9.1.3   | N(org)             | 2.8                            |
| HY.SW                | RW       | HY.SW-RW-load      | N-load in trans-boundary outflows            | 10.2.3  | NO3,<br>N(org)     | 313.4                          |
| <b>Total Exports</b> |          |                    |  |         |                    | <b>3651.6</b>                  |

<sup>a</sup> Note: With the exception of imports of manure, agricultural imports and exports are included in the sub-pool “Food and feed processing”.

Tab. 11-2 shows the trans-boundary N-flows summarized for the most important pools and sub-pools.

Table 11-2: Imports and exports of reactive nitrogen for pools or sub-pools, annual mean for 2010 – 2014.

| Pool or Sub-pool <sup>a</sup>                                |  | N-species                             | Import <sup>b</sup><br>kt N a <sup>-1</sup> | Export <sup>b</sup><br>kt N a <sup>-1</sup> | Balance <sup>b</sup><br>kt N a <sup>-1</sup> |
|--|--|---------------------------------------|---|---|--|
| AT   | Atmosphere   | NH <sub>y</sub> , NO <sub>x</sub>     | 218   | - 529                                       | - 311  |
| EF.EC  | Energy conversion <sup>c</sup>                       | N(org)                                | (1735)                                      | (63)  | (1672)                                       |
| MP.FP  | Food and Feed Processing<br>- of which Feed          | N(org)                                | 904 <sup>d</sup><br>(405) <sup>e</sup>      | - 635<br><sup>e</sup>                       | 269<br>405 <sup>e</sup>                      |
| MP.NC  | Nitrogen chemistry<br>- of which Fertiliser          | N(org)                                | 2262<br>1028                                | - 1797<br>-580                              | 465<br>448                                   |
| MP.OP,<br>WS.SW  | Other producing industry <sup>f</sup><br>Solid waste | N(org)                                | 325   | - 314                                       | 11   |
| HY.SW  | Surface waters                                       | NO <sub>3</sub> <sup>-</sup> , N(org) | 67  | - 313                                       | - 246  |
| <b>Totals <sup>c</sup> (not including energy conversion)</b> |  |                                       | <b>3776 <sup>c</sup></b>                    | <b>- 3588 <sup>c</sup></b>                  | <b>188 <sup>c</sup></b>                      |

<sup>a</sup> Pools or sub-pools that are not included have low or no imports and exports; Agriculture imports and exports fall under the “Material and Products in Industry” pool.

<sup>b</sup> N-flows are rounded to whole numbers; negative value show exports or net exports; discrepancies are due to rounding.

<sup>c</sup> Imports and exports for energy conversion are not included here on the assumption that the combustion of fuels only releases relatively small amounts of NO<sub>x</sub> and N<sub>2</sub>O into the environment.

<sup>d</sup> Including manure imports.

<sup>e</sup> Exports not shown, statistics are already net imports (taken from the BMEL statistics).

<sup>f</sup> Including import or export of round wood.

Pools in Germany show a slight net import of 188 kt N a<sup>-1</sup> (not including the N-flow with fuels, see Table 11-2, Footnote c). However, two opposing components are involved. With the atmospheric transport of gaseous N<sub>r</sub> and the downstream N-outflow in rivers, Germany exports (net) -557 kt N a<sup>-1</sup> of reactive nitrogen (NO<sub>3</sub><sup>-</sup>, NH<sub>3</sub>, NO<sub>x</sub>) in the hydrosphere and the atmosphere to neighbouring countries. Including the N-load of 187 kt N a<sup>-1</sup> that is discharged into the North Sea and Baltic Sea (which is not an export under the NNB system), gives an outflow of -744 kt N a<sup>-1</sup> from German territories via the biosphere. On the other hand, there are net-imports of 745 kt N a<sup>-1</sup> in the form of products in food and feed processing and in the chemical industry (not including fuels). Therefore the import-export balance in total is balanced.

The “Agriculture” pool is not shown in Tab. 11-2 because all trans-boundary N-flows in this sector are registered under the sub-pools “Food and Feed Processing” and “Nitrogen Chemistry” in accordance with the NNB system (ECE 2013). The N<sub>r</sub>-flows relating to Germany’s imports, however, end up to a large extent in the “Agriculture” pool. In sub-pool “Food and Feed processing”, feed accounts for 45 % of the N<sub>r</sub> net imports; in foreign trade with products of the chemicals industry, mineral fertiliser accounts for 45 % of the N<sub>r</sub> imports and 32 % of N<sub>r</sub> exports.

Concerning the trade balance for sub-pool “Food and Feed Processing”, it should be noted that agriculture records feed imports of 405 kt N a<sup>-1</sup>, which is about 20 % of the total amount of nitrogen (or crude protein) in the total amount of feed deployed. But on the other hand, Germany is also a relevant exporter of unprocessed and processed agricultural products (grain, meat, dairy products), so that food and feed only accounts for a relatively small trade deficit of 269 kt N a<sup>-1</sup>.



## 12 Presenting N-flows with STAN

Pools, sub-pools and N-flows are presented with the Substance Flow Analysis program STAN 2.6.801 (TU Vienna, www.stan2web.net). Figure 12-1 shows the overall system of the National N-Balance with eight pools and the N-flows between the pools. Trans-boundary N-flows are shown as imports and exports.

Figure 12-1: Nitrogen-pools, sub-pools and N-flows (in kt N a<sup>-1</sup>, annual mean for 2010 – 2014) of the German national nitrogen budget.

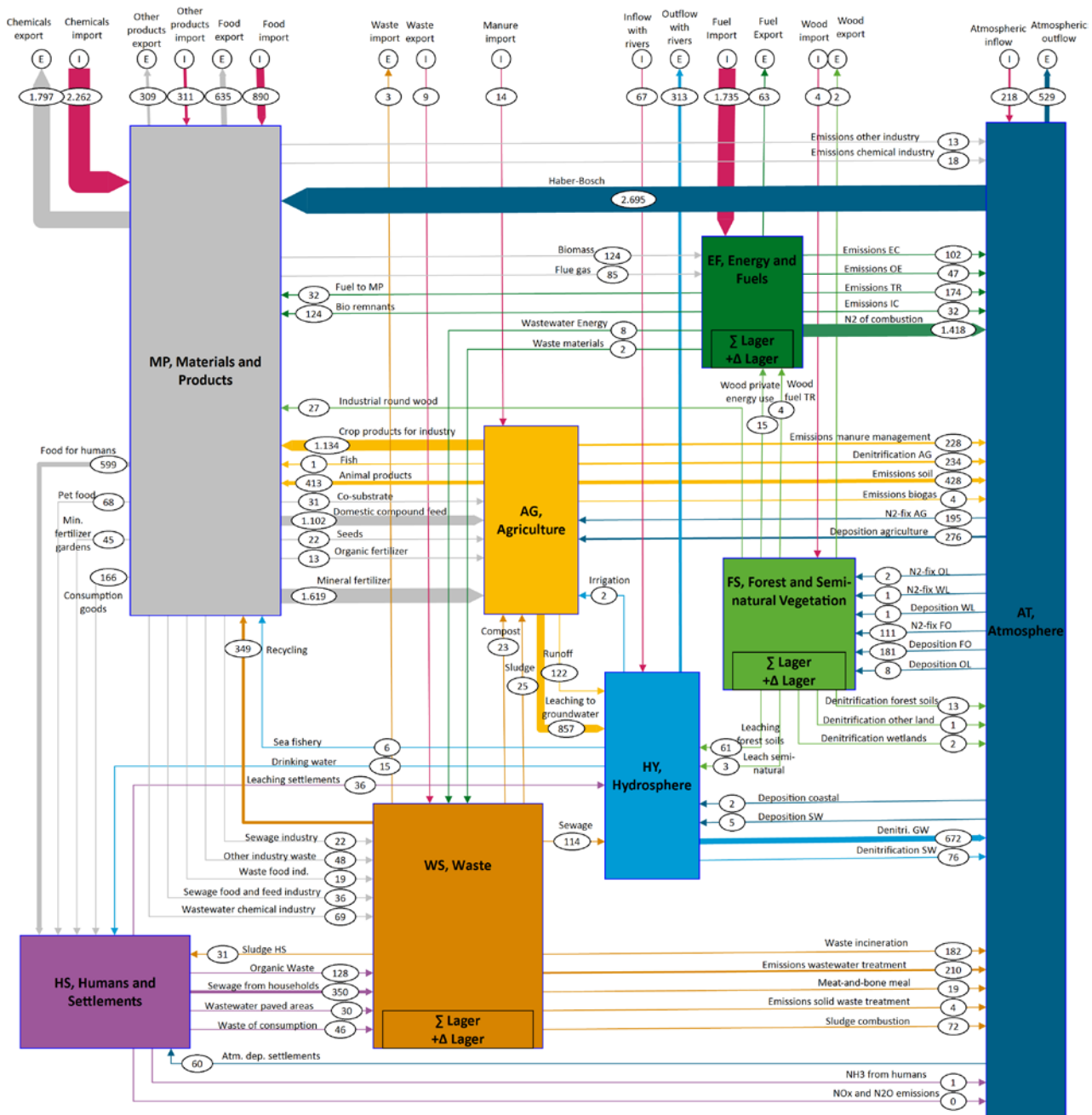

National N-budget with the eight pools “Atmosphere” (AT), “Energy and Fuels” (EF), “Material and Products in Industry” (MP), “Humans and Settlements” (HS), “Agriculture” (AG), “Forest and semi-natural vegetation” (FS), “Waste” (WS), and “Hydrosphere” (HY), including N-flows between the pools (in kt N a<sup>-1</sup>). Trans-boundary N-flows are shown as exports and imports. The thickness of the arrow is proportional to the magnitude of the flow. The colour of the flow corresponds to that of the source pool. Data sources: see Chapters 3 to 11.

Figures 12-2 to 12-9 show the eight pools described in Chapters 3 to 10 and their sub-pools with nitrogen inflows and outflows.

Figure 12-2: “Atmosphere” pool with nitrogen inflows and outflows (in kt N a<sup>-1</sup>, annual mean for 2010 – 2014).

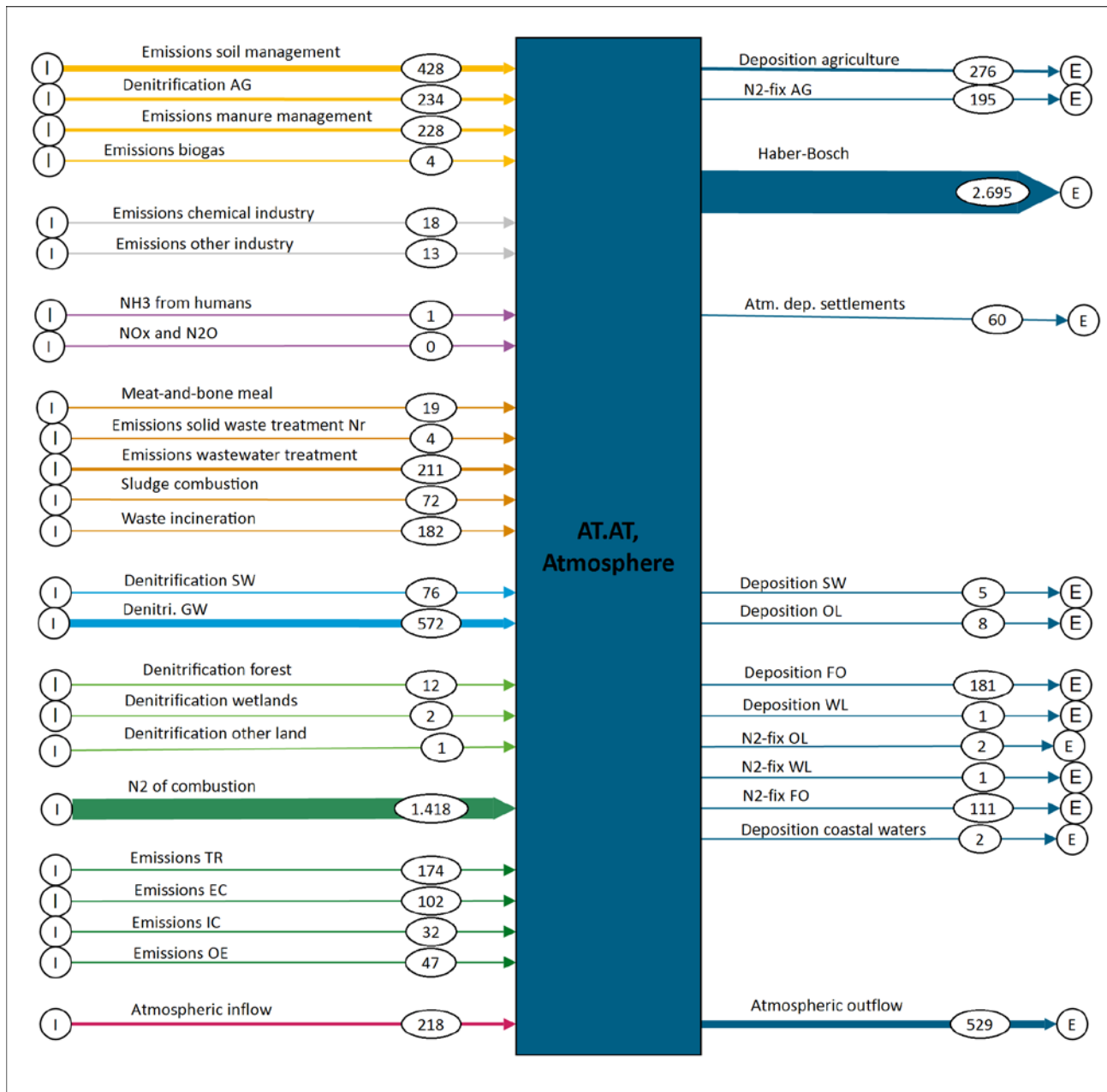

“Atmosphere” (AT) pool with nitrogen inflows and outflows in accordance with Chapter 3. Rounded values in kt N a<sup>-1</sup> per flow. The thickness of the arrow is proportional to the magnitude of the flow. The colour of the flow corresponds to that of the source pool, see Fig. 12-1. Data sources: see Chapters 3 to 11.

Figure 12-3: “Energy and Fuels” pool and its sub-pools with nitrogen inflows and outflows (in kt N a<sup>-1</sup>, annual mean for 2010 – 2014).

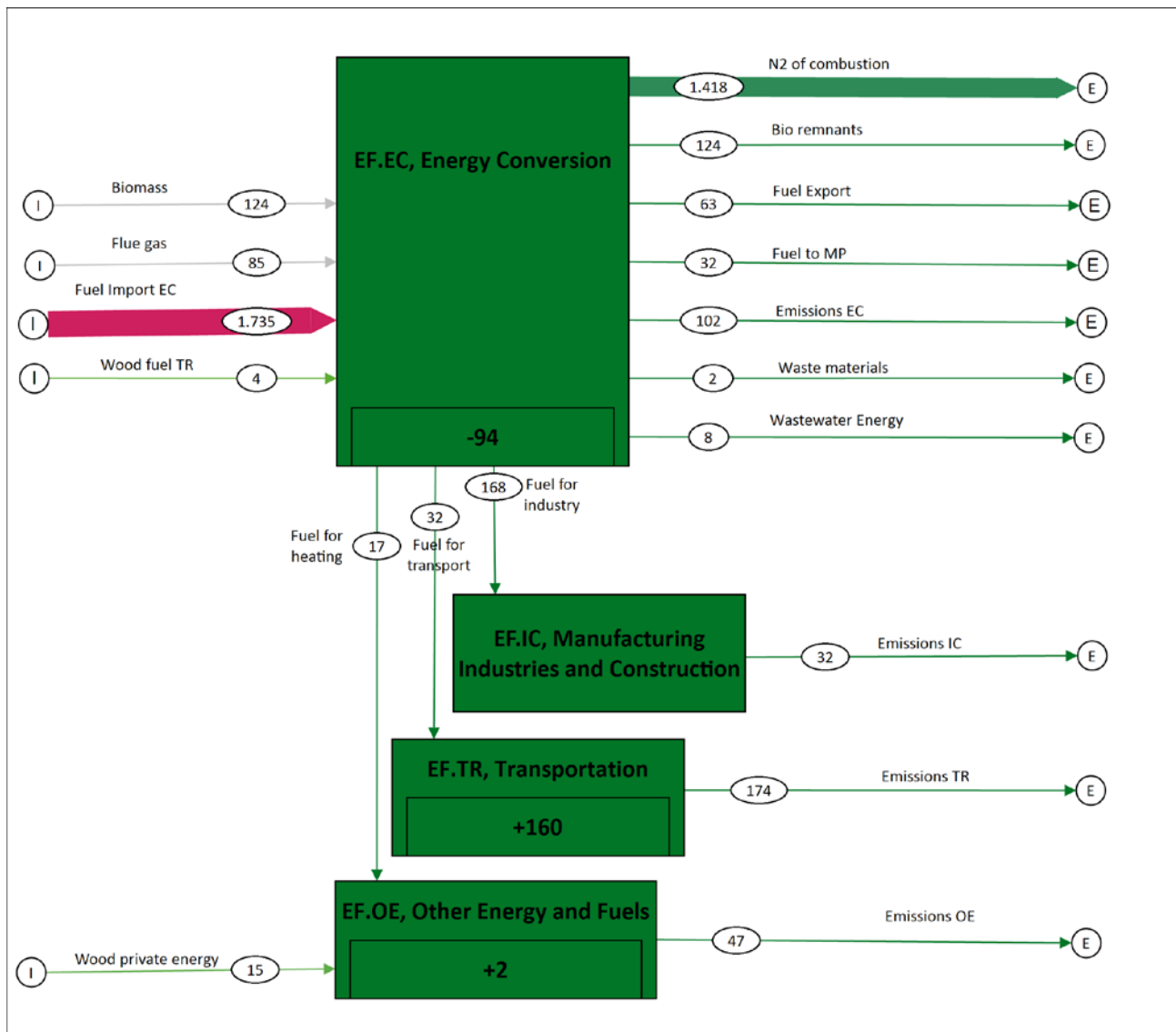

“Energy and Fuels” (EF) pool with the sub-pools “Energy Conversion” (EF.EC), “Manufacturing Industries and Construction” (EF.IC), “Transport” (EF.TR), and “Other Energy and Fuels” (EF.OE), as well as inflows and outflows of nitrogen in accordance with Chapter 4. Rounded values in kt N a<sup>-1</sup> per flow; the thickness of the arrow is proportional to the magnitude of the flow. The colour of the flow corresponds to that of the source pool, see Fig. 12-1. Data sources see Chapters 3 to 11.

Figure 12-4: “Material and Products in Industry” pool and its sub-pools with nitrogen inflows and outflows (in kt N a<sup>-1</sup>, annual mean for 2010 – 2014).

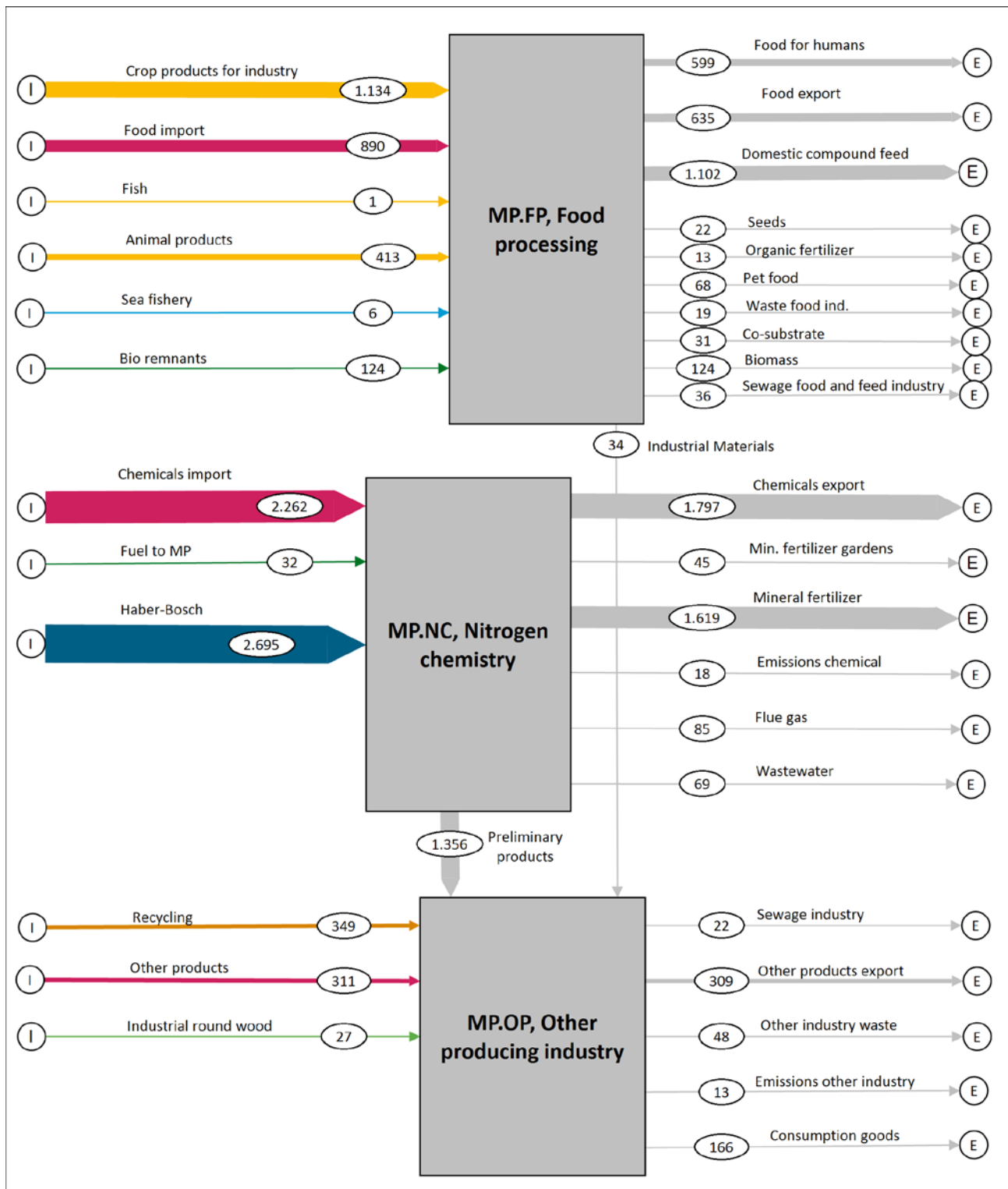

“Material and Products in Industry” (MP) pool with the sub-pools “Food and Feed Processing” (MP.FP), “Nitrogen Chemistry” (MP.NC) and “Other Producing Industry” (MP.OP), as well as inflows and outflows of nitrogen in accordance with Chapter 5. Rounded values in kt N a<sup>-1</sup> per flow; the thickness of the arrow is proportional to the magnitude of the flow. The colour of the flow corresponds to that of the source pool, see Fig. 12-1. Data sources see Chapters 3 to 11.

Figure 12-5: “Humans and Settlements” pool and its sub-pools with nitrogen inflows and outflows (in kt N a<sup>-1</sup>, annual mean for 2010 – 2014).

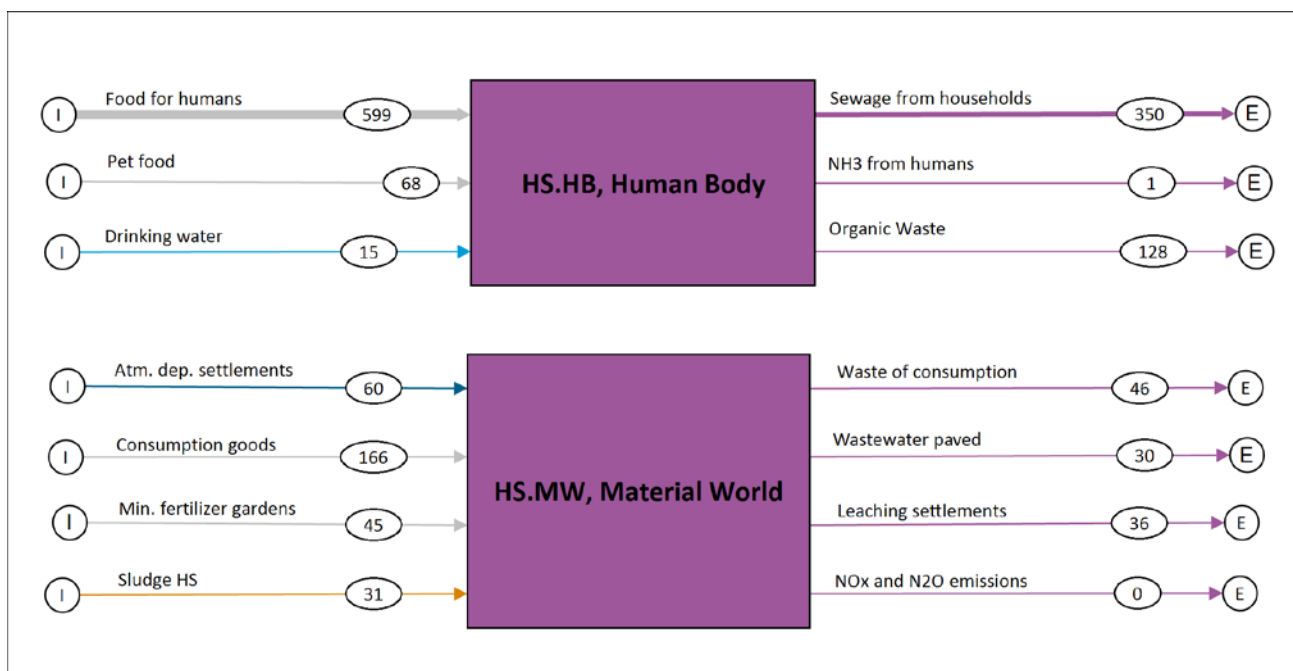

“Humans and Settlements” (HS) pool with the sub-pools “Human Body” (HS.HB, including pets) and “Material World” (HS.MW), as well as inflows and outflows of nitrogen in accordance with Chapter 6. Rounded values in kt N a<sup>-1</sup> per flow; the thickness of the arrow is proportional to the magnitude of the flow. The colour of the flow corresponds to that of the source pool, see Fig. 12-1. Data sources see Chapters 3 to 11.

Figure 12-6: “Agriculture” pool and its sub-pools with nitrogen inflows and outflows (in kt N a<sup>-1</sup>, annual mean for 2010 – 2014).

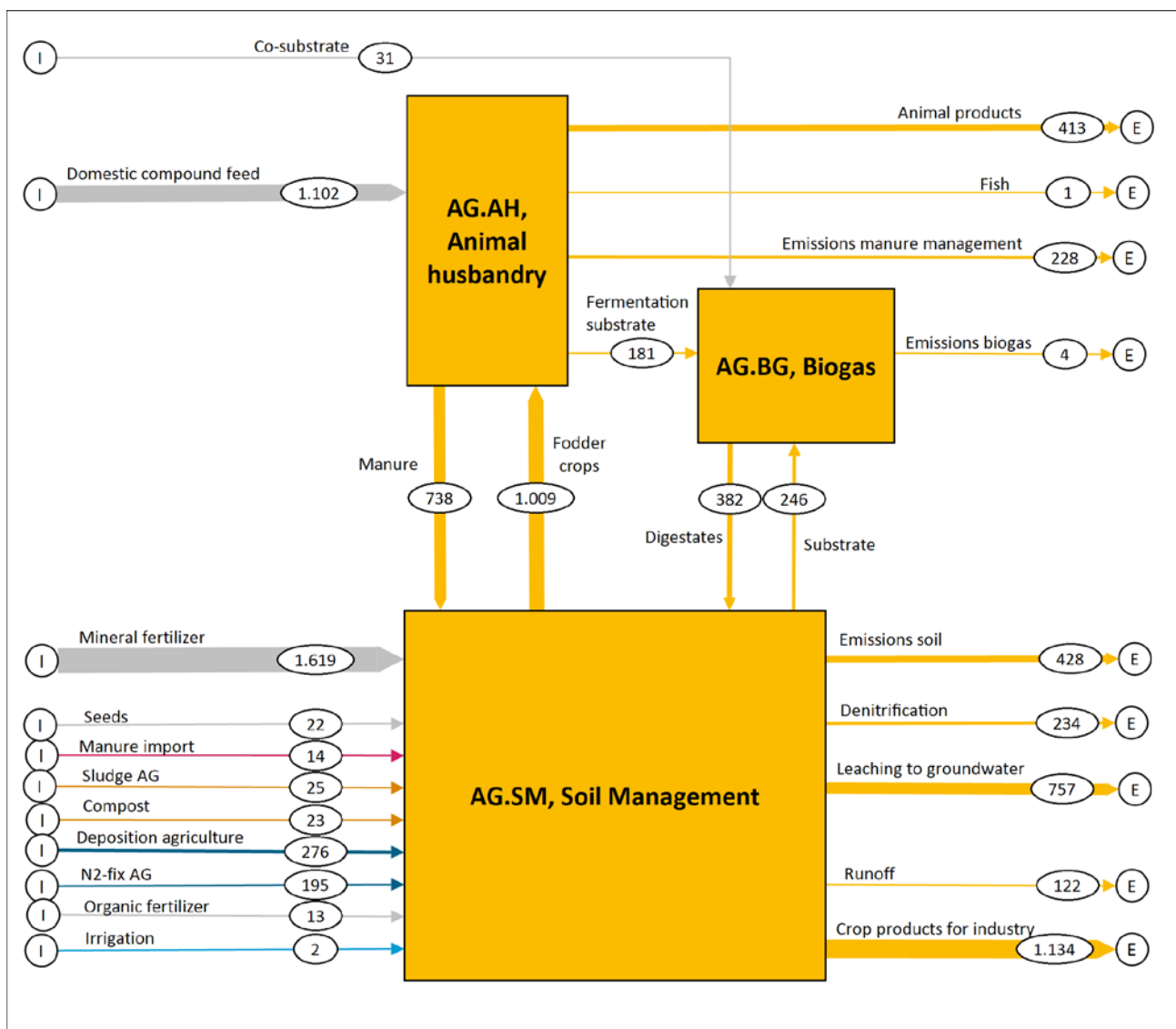

“Agriculture” (AG) pool with the sub-pools “Animal Husbandry” (AG.AH), “Soil Management” (AG.SM) and “Biogas Production” (AG.BG), as well as inflows and outflows of nitrogen in accordance with Chapter 7. Rounded values in kt N a<sup>-1</sup> per flow; the thickness of the arrow is proportional to the magnitude of the flow. The colour of the flow corresponds to that of the source pool, see Fig. 12-1. Data sources see Chapters 3 to 11.

Figure 12-7: “Forest and Semi-natural Vegetation” pool and its sub-pools with inflows and outflows (in kt N a<sup>-1</sup>, annual mean for 2010 – 2014).

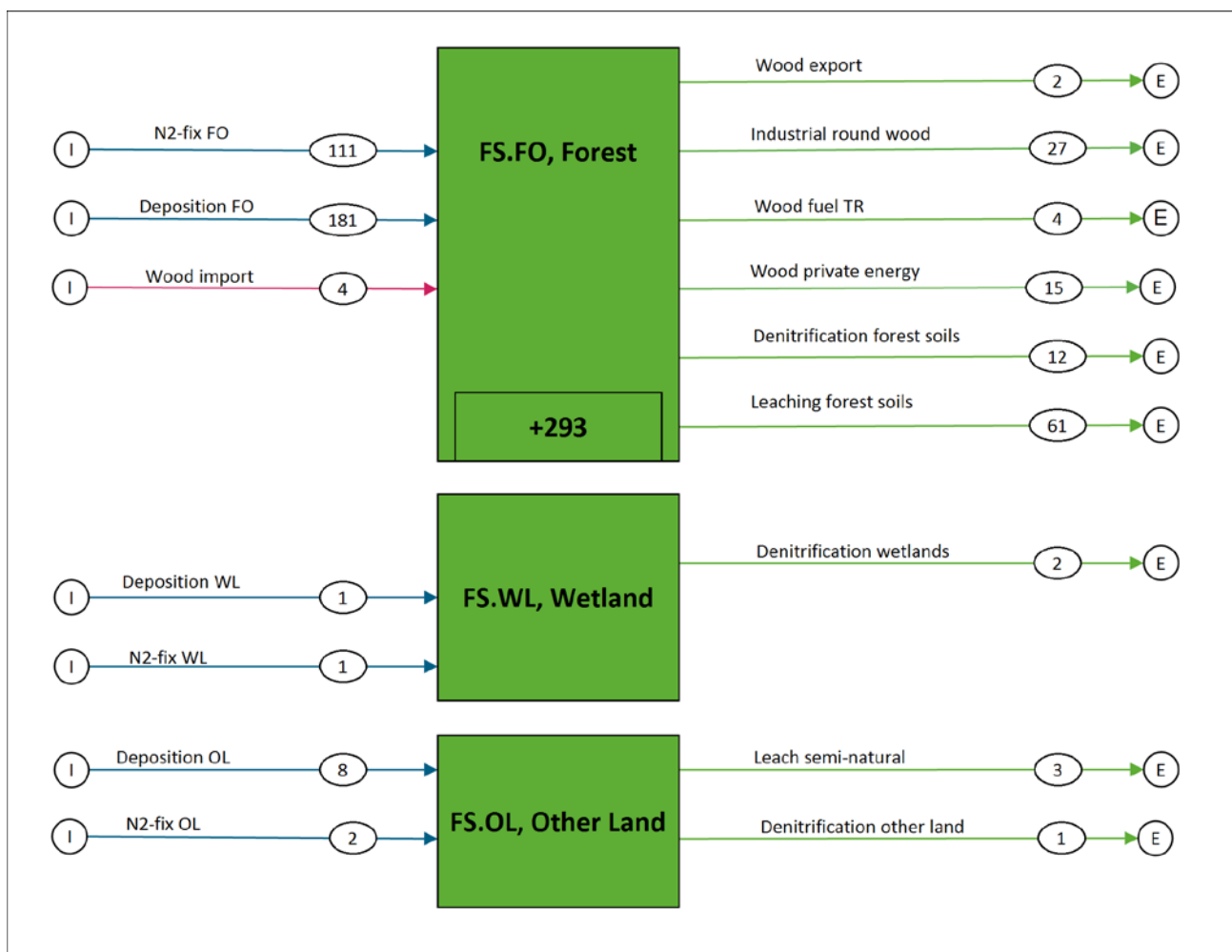

“Forest and Semi-natural Vegetation” (FS) pool with the sub-pools Forest” (FS), Wetland (FS.WL) and Other Land (FS.OL) as well as quantitatively relevant inflows and outflows in accordance with Chapter 8. Rounded values in kt N a<sup>-1</sup> per flow; the thickness of the arrow is proportional to the magnitude of the flow. The colour of the flow corresponds to that of the source pool, see Fig. 12-1. Data sources see Chapters 3 to 11.





Figure 12-9: “Hydrosphere” pool and its sub-pools with inflows and outflows (in kt N a<sup>-1</sup>, annual mean for 2010 – 2014).

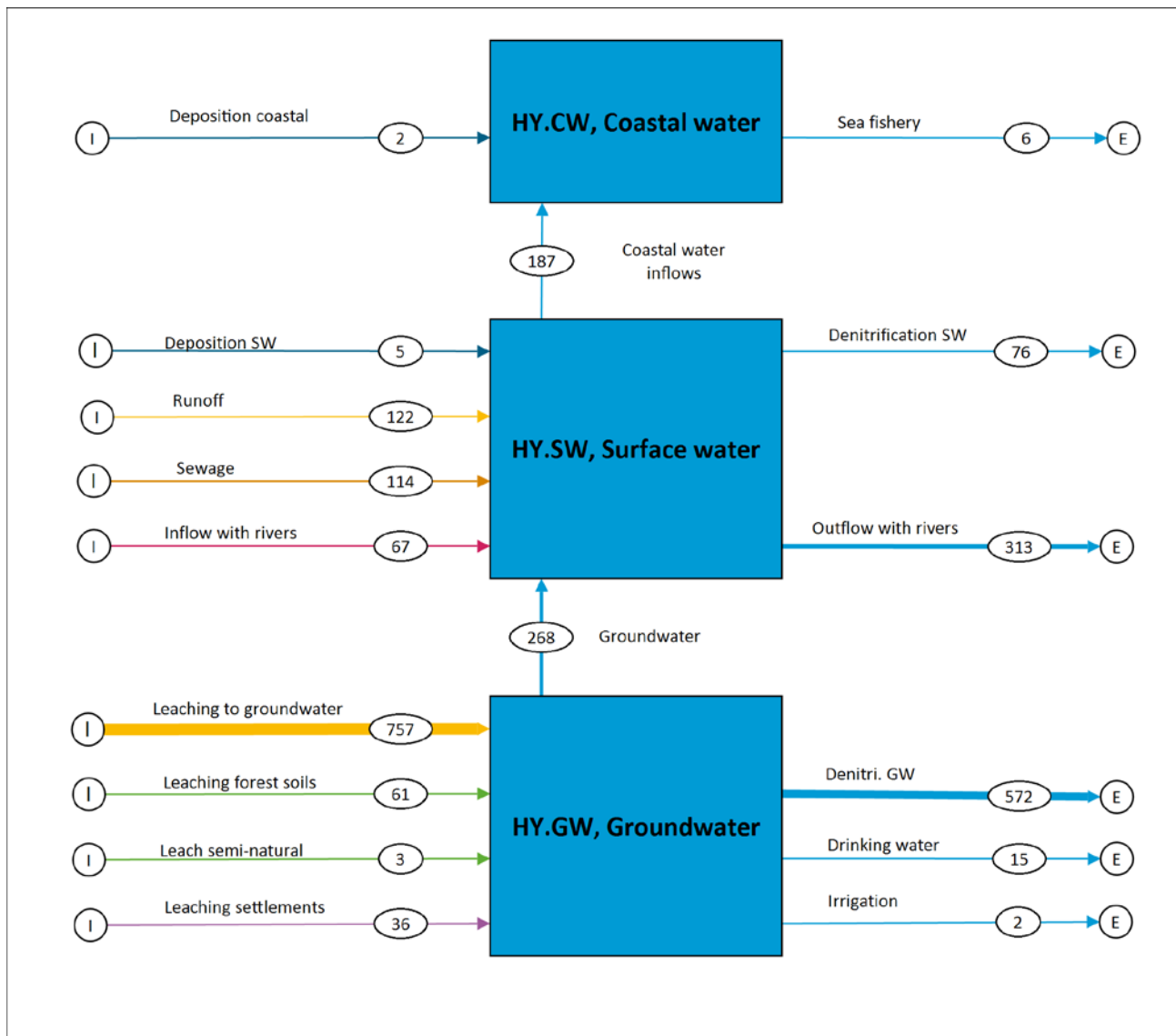

Pool “Hydrosphere” (HY) with the sub-pools “Surface waters” (HY.SW), “Coastal waters” (HY.CW) and “Groundwater” (HY.GW) as well as inflows and outflows in accordance with Chapter 10. Rounded values in kt N a<sup>-1</sup> per flow; the thickness of the arrow is proportional to the magnitude of the flow. The colour of the flow corresponds to that of the source pool, see Fig. 12-1. For data sources see Chapters 3 to 11.

### 13 Overview and balance of N-flows for Germany

A national nitrogen budget can help to determine how much reactive nitrogen is newly generated or is introduced into the nitrogen cycle every year, and how much of the  $N_r$  is reduced or oxidised to molecular nitrogen ( $N_2$ ). Tab. 13-1 shows a summary of the sources and sinks of  $N_r$  in Germany.

Table 13-1: Sources and sinks of reactive nitrogen in Germany, annual mean for 2010 – 2014.

| Process   | N-species          | N-flow <sup>a</sup><br>kt N a <sup>-1</sup> |
|---|--------------------|---|
| NH <sub>3</sub> synthesis (Haber-Bosch process) <sup>b</sup>  | NH <sub>3</sub>    | 2695  |
| Domestic extraction and (net-)import of fossil fuels<br>- of which: Crude oil   | N(org)             | 2335<br>930                                 |
| N-fixing in soil (agriculture, forest, semi-natural areas)  | N(org)             | 308   |
| Formation of thermal NO <sub>x</sub> <sup>c</sup>   | NO <sub>x</sub>    | 192   |
| Trade balance (net import) Food and Industry <sup>d</sup>   | all N <sub>r</sub> | 745   |
| <b>Total Sources</b>  |                    | <b>6275</b>                                 |
| Combustion of fossil and regenerative fuel and flue gas denoxing<br>(oxidation/reduction of N <sub>r</sub> in fuel to N <sub>2</sub> ) <sup>e</sup> | N <sub>2</sub>     | - 1893 <sup>e</sup>                         |
| N <sub>r</sub> "loss" in crude oil refining <sup>f</sup>  | N <sub>2</sub>     | - 818 <sup>f</sup>                          |
| Denitrification total,  | N <sub>2</sub>     | - 1107                                      |
| of which in - Soils (agriculture, forest, semi-natural areas)   |                    | - 248                                       |
| - Waters (groundwater <sup>g</sup> , surface waters <sup>h</sup> )  |                    | - 648                                       |
| - Solid waste (Wastewater treatment plants)   |                    | - 211                                       |
| Waste landfill  | N(org)             | - 86  |
| Net-export via atmosphere   |                    | - 311                                       |
| Net export with river discharge <sup>i</sup>  |                    | - 433                                       |
| <b>Total Sinks</b>  |                    | <b>- 4648</b>                               |
| <b>Difference between source and sink flows</b>   |                    | <b>1627<sup>j</sup></b>                     |

<sup>a</sup> N-flows are rounded.

<sup>b</sup> Including synthesis of calcium cyanamide.

<sup>c</sup> Approx. 50 % of total NO<sub>x</sub>, see Section 4.1.2 (Tab. 4-4).

<sup>d</sup> Not including Energy Conversion, see Tab. 11-2.

<sup>e</sup> Combustion of fossil fuels and denoxing of flue gases (Section 4.1.5) as well as combustion of regenerative fuels, waste (Tab. 9-3), sludge (Tab. 9-3), bone meal (Tab. 5-5) and wood (private households, Tab. 8-4)

<sup>f</sup> On "loss" see Section 4.1.1.

<sup>g</sup> Denitrification of 572 kt N a<sup>-1</sup> in the unsaturated zone (below the root zone) and in groundwater.

<sup>h</sup> Retention of 75.9 kt N a<sup>-1</sup> in surface waters is allocated to denitrification.

<sup>i</sup> Contrary to Section 10.3 and Table 11-2, water discharge into the coastal seas is already treated as export here.

<sup>j</sup> For the difference to "Total reactive nitrogen emissions from anthropogenic sources" of 1547 kt N a<sup>-1</sup> in Table 13-3 see text.

Ammonia synthesis accounts for some 43 % of the total of 6275 kt N<sub>r</sub> that is newly generated or brought into circulation every year. Slightly less is introduced into the nitrogen cycle by the extraction and net imports of fuels containing nitrogen (lignite, coal, crude oil). The combustion of these fuels at high temperatures forms 192 kt N<sub>r</sub> a<sup>-1</sup> as thermal NO<sub>x</sub> (N<sub>2</sub> from the air is oxidised to NO<sub>x</sub>). The natural process of nitrogen fixation in soils generates 308 kt N<sub>r</sub> a<sup>-1</sup>, which is only 5 % of the annual total.

The most important sink is energy conversion: the denoxing of flue gases from the combustion processes with fossil fuels (coal, lignite, oil products) and the incineration of waste, sludge, bone meal and wood converts 1893 kt N<sub>r</sub> a<sup>-1</sup> into N<sub>2</sub>, and the refining of crude oil converts another 818 kt N<sub>r</sub> a<sup>-1</sup>. As a natural process, denitrification in the hydrosphere, soils and wastewater treatment plants total-ling 1107 kt N a<sup>-1</sup> accounts for some 24 % of the conversion of N<sub>r</sub> to molecular N<sub>2</sub>. A total of 744 kt N a<sup>-1</sup> (net) is imported in chemical products and the produce of food and feed processing, whereas 557 kt N a<sup>-1</sup> (net) is exported to neighbouring countries via the hydrosphere and the atmosphere, so that the trade balance is 188 kt N a<sup>-1</sup>, with regard to the North Sea and Baltic Sea as system boundary of the NNB. If, contrary to ECE (2013) and Table 11-2, the NNB system boundary is already drawn at the coast or at the river estuaries, the import-export balance is equalized.

The annual addition to the amount of reactive nitrogen (including extraction and net imports) is 6275 kt N<sub>r</sub>, but the figure for the annual reduction is 26% lower, at 4648 kt N<sub>r</sub>. There are two explanations for this difference of 1627 kt N<sub>r</sub>.

- ▶ The difference corresponds to the surplus in Germany's National N budget, i.e. the amount of reactive N in the environment is increased annually by this amount ("accelerating the N-cascade").
- ▶ The difference may be the result of uncertainties in determining N-flows due to inadequate statistics about goods flows and the N-contents of commodities, and the lack of knowledge about factors influencing the biochemical processes with which nitrogen is bound and denitrified.

Furthermore, changes in N stocks (mainly in soils) that are not considered as sources or sinks of N-flows in the NBB calculation scheme can also contribute to the difference.

Theoretically, the totals of the nitrogen inflows and of the outflows should be nearly equal both for each individual pool and for the national nitrogen budget (as aggregate of the pools). However, Tab. 13-2 shows that this is not the case for most pools and sub-pools. In the two cases where no differences are shown (sub-pool "Nitrogen chemistry" and the "Agriculture" pool), the inflows and outflows were made to balance by introducing difference values in the calculations.

The increase or decrease in N-stocks in agriculture, the food industry, energy conversion, and commodity production over a five-year period is negligible, as the evaluated statistics show. For the "Forest" pool a reduction of the N-stock of 293 kt N a<sup>-1</sup> is reported for the forest soils (Section 8.1.6), which would have to be included in the nitrogen budget as an input (mobilisation of N<sub>r</sub>), but this would only further increase the difference.

The addition of 17 kt N a<sup>-1</sup> in timber stocks in forests by no means compensates for this decrease in stocks in soils. According to preliminary estimates (Section 7.5.2), the depletion of N-stocks in utilised agricultural mineral and moor soils is in the order of 500 kt N a<sup>-1</sup>. However, this value is not included in the nitrogen budget due to the uncertainty of the estimates. The greatest uncertainty with regard to changes in N-stocks relates to the movements of nitrates in the "root zone - unsaturated zone - groundwater" system. The amount of NO<sub>3</sub><sup>-</sup> in these compartments in Germany as a whole is unknown, and it is impossible to make plausible estimates of the changes resulting from water exchanges and/or denitrification.

Table 13-2: Comparison of the nitrogen inflows and outflows of the pools or sub-pools, annual mean for 2010 – 2014.

| Pool or Sub-pool                               | Inflow<br>kt N a <sup>-1</sup> | Outflow<br>kt N a <sup>-1</sup> | Difference <sup>b</sup><br>kt N a <sup>-1</sup> |
|--|--------------------------------|---------------------------------|---|
| Atmosphere                                     | 1271                           | - 1062                          | 209   |
| Energy Conversion                              | 2662                           | - 2632                          | 30  |
| Sub-pool Food and Feed Processing              | 2568                           | - 2684                          | - 116   |
| Sub-pool Nitrogen chemistry                    | 4989                           | - 4989                          | 0   |
| Sub-pool Other Producing Industry              | 2078                           | - 558                           | 1520  |
| Sub-pool Human Body (and pets)                 | 683                            | - 479                           | 204   |
| Sub-pool Material world (and settlement areas) | 302                            | - 112                           | 190   |
| Agriculture                                    | 3320                           | - 3320                          | 0   |
| Forest and semi-natural vegetation             | 308 <sup>a</sup>               | - 126 <sup>a</sup>              | 181   |
| Sub-pool Solid waste                           | 345                            | - 732                           | - 386   |
| Sub-pool Wastewater                            | 514                            | - 479                           | 36  |
| Hydrosphere                                    | 1167                           | - 985                           | 183   |
| Rest of World                                  | 3776                           | - 3588                          | 188   |
| <b>Totals inflow, outflow and difference</b>   | <b>23983</b>                   | <b>- 21746</b>                  | <b>2237</b>                                     |

<sup>a</sup> Not including the reduction in N-stock of 293 kt N a<sup>-1</sup> in forest soils.

<sup>b</sup> Discrepancies are due to rounding.

In view of these uncertainties in the national nitrogen budget, the results must be interpreted with some caution. For more reliable values or for future updates, the statistical data basis for a number of N-flows must be improved, which will require the support of experts from the relevant institutions. However, despite these reservations, the annual net introduction of reactive nitrogen in Germany is in the order of 1600 kt N a<sup>-1</sup>. It is not possible to determine the species of reactive nitrogen involved, or the environmental media in which they accumulate. However, there can be little doubt that urgent measures are needed that bring about considerable reductions in the emissions of reactive nitrogen into the environment.

Table 13-3 provides a summary of emitting groups and the quantities and percentages of N<sub>r</sub> emissions from anthropogenous sources into air and surface waters. The sum of 1547 kt N a<sup>-1</sup> differs from the 1627 kt N a<sup>-1</sup> given in Table 13-1 because Table 13-3 is based on different system boundaries: Table 13-1 shows the difference between sources and sinks, i.e. the uncertainties in the totals are included in the difference, whereas in Table 13-3 only the anthropogenic emissions are presented. Furthermore, in Table 13-1 the net export to surface waters is accounted, while in Table 13-3 the NO<sub>3</sub> input to groundwater is considered as emission. The values show that agriculture accounts for two-thirds of all reactive nitrogen released in Germany and remains by far the most important source of N<sub>r</sub> emissions into both the atmosphere and the hydrosphere. Indeed, in view of the greater reductions of N<sub>r</sub> emissions in the other sectors in recent decades, agriculture now accounts for an even higher proportion than in previous calculations (for 2008-2010, see Table 2 in UBA 2015). This finding emphasises the urgent need for effective reduction measures in this sector.

Table 13-3: Emitting groups, and quantities <sup>a</sup> and percentages of key N<sub>r</sub> emissions from anthropogenous sources <sup>b</sup> into air and surface waters, annual mean for 2010 – 2014.

| Emitting group  | Pool/<br>Sub-pool       | Air                                     |   |  | Surface<br>waters <sup>c</sup>                       | Total<br>kt N a <sup>-1</sup> | %     |
|---|-------------------------|---|---|--|--|-------------------------------|-------|
|   |                         | NO <sub>x</sub><br>kt N a <sup>-1</sup> | NH <sub>3</sub><br>kt N a <sup>-1</sup> | N <sub>2</sub> O<br>kt N a <sup>-1</sup> | NO <sub>3</sub> <sup>-</sup><br>kt N a <sup>-1</sup> |                               |       |
| Agriculture   | AG                      | 36.0                                    | 558.0                                   | 65.4                                     | Runoff 113.7<br>GW <sup>d</sup> 268.2                | <b>1041.3</b>                 | 67 %  |
| Transport   | EF.TR                   | 159.6                                   | 11.5                                    | 3.0                                      | 0.0  | <b>174.1</b>                  | 11 %  |
| Industry / Energy<br>Conversion <sup>e</sup>                              | EF (minus<br>EF.TR); MP | 184.2                                   | 16.6                                    | 11.7                                     | 29.9   | <b>242.4</b>                  | 16 %  |
| Households /<br>wastewater treatment<br>plants / urban areas <sup>f</sup> | HS<br>WS                | 0.1                                     | 2.9                                     | 2.1                                      | 84.4   | <b>89.5</b>                   | 6 %   |
| <b>Total</b>  |                         | <b>379.9</b>                            | <b>589.0</b>                            | <b>82.2</b>                              | <b>496.2</b>   | <b>1547.3</b>                 |       |
| Proportion  |                         | 25 %                                    | 38 %                                    | 5 %                                      | 32 %   |                               | 100 % |

<sup>a</sup> *Italics*: Data taken from other publications; other values were determined in the course of this study.

<sup>b</sup> Emissions from Forest and semi-natural vegetation are not included.

<sup>c</sup> The total input from wastewater treatment plants/settlement water management (114.3 kt N/a) is divided between HS and EF+MP proportional to their inputs into wastewater treatment plants. Cf. Section 9.2.3.  
Input from Agriculture: only NO<sub>3</sub><sup>-</sup>, without N(org).

<sup>d</sup> GW-Groundwater. As a simplification, the entire NO<sub>3</sub><sup>-</sup> load in groundwater is included under Agriculture.

<sup>e</sup> Including gaseous emissions from waste incineration and wastewater treatment plants.

<sup>f</sup> Gaseous emissions from combustion installations in households are included in pool EF.

In addition to determining the N-flows in Germany, the remit of the DESTINO Project was also to develop an integrated nitrogen indicator for Germany which characterises the current situation across sectors and media (see DESTINO Report 1, UBA 2020). On the basis of a national nitrogen target value which reflects the critical limits, the integrated nitrogen indicator would also quantify the necessary reduction of N<sub>r</sub> emissions. The N<sub>r</sub> emissions for the nitrogen indicator were in part determined using different methodological approaches, and over different time windows than the period 2010-2014 we have used here. The N-quantities in Table 13-3 are therefore not always directly comparable with those in Table 10 of Report 1 (UBA 2020). The integrated nitrogen indicator and the N-flow balance, while addressing the issue of reactive nitrogen from different perspectives, both demonstrate clearly that this topic, alongside climate change, is one of the most pressing environmental problems currently faced.

Figure 13-1: Emissions of reactive nitrogen from anthropogenous sources into the air ( $\text{NO}_x$ ,  $\text{NH}_3$ ,  $\text{N}_2\text{O}$ ) and surface waters ( $\text{NO}_3^-$ ) according to nitrogen-species and emitter groups, annual mean for 2010 - 2014.

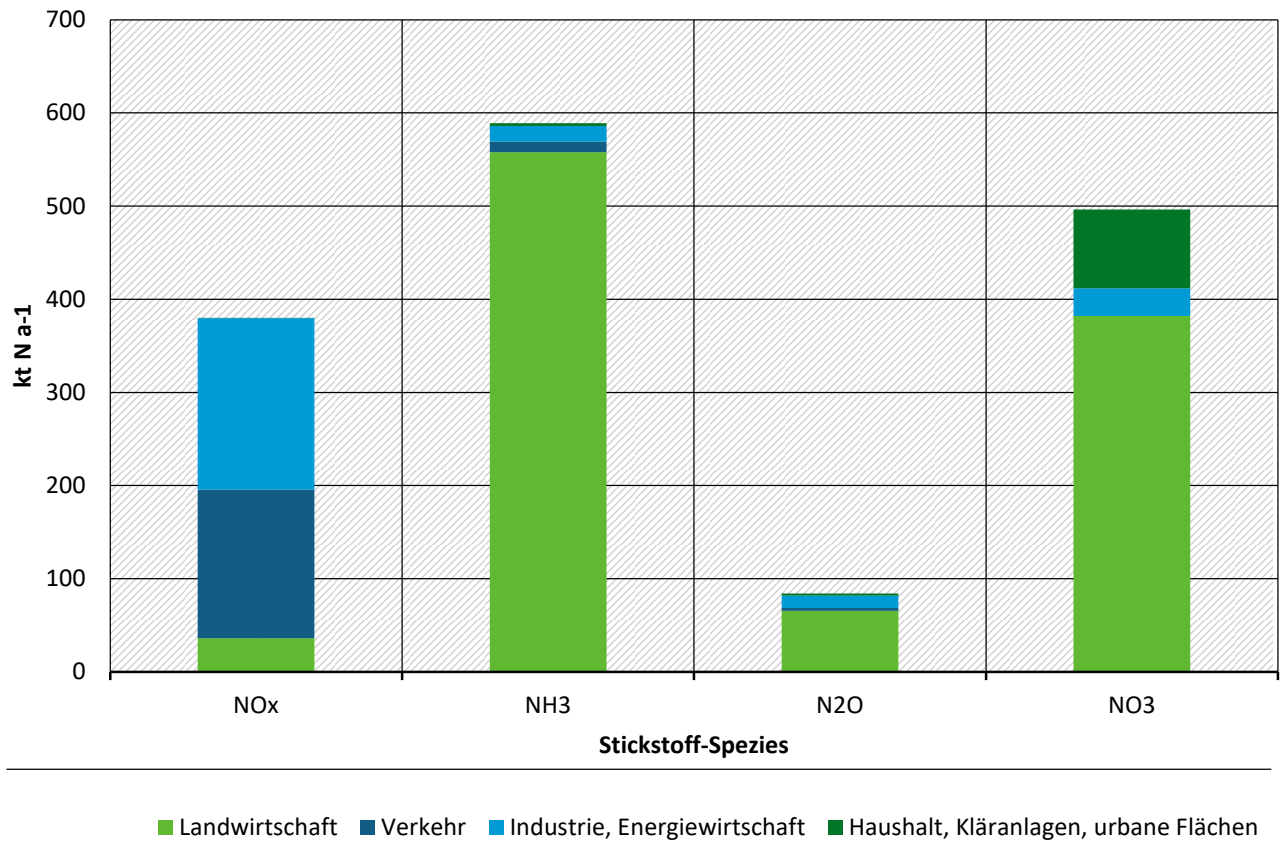

## 14 Conclusions

How much reactive nitrogen is introduced into the nitrogen cycle each year, and where does it come from? Where does this N go? How reliable are the results about the N-flows?

These are the central questions regarding the national budget for reactive nitrogen flows. A well-founded result of the nitrogen balance is that ammonia synthesis in Germany currently introduces 8-10-times more  $N_r$  into the nitrogen-cycle than the natural process of nitrogen fixation in soils. Human intervention is greater in the nitrogen cycle than in any other global geochemical cycle. As a further illustration of the size of the problem, in Germany ammonia synthesis alone ( $2690 \text{ kt N a}^{-1}$ ) produces more reactive nitrogen every year than the total amount stored in German forest trees ( $\sim 2260 \text{ kt N}$ ).

The comparison of sources and sinks of reactive nitrogen in Germany (Table 13-1) shows a net annual release of reactive nitrogen in Germany in the order of  $1600 \text{ kt N a}^{-1}$ . A more precise assessment is not possible, firstly because the uncertain statistical data for the input material flows and their N-contents. There is also insufficient knowledge about denitrification in soils, waters, and solid waste. Further investigations are required if the national nitrogen budget is to provide more reliable results. However, the comprehensive registration of all nitrogen flows proves to be very demanding, and in a number of cases large uncertainties are involved. With regard to the key issue of estimating the net emissions of reactive nitrogen, it would seem more expedient in future to focus on the key components of the nitrogen budget:

(i) The production of reactive nitrogen by technical means and by nitrogen fixation in soils; (ii) The denitrification of nitrogen compounds in soil to form  $N_2$ , both naturally and in technical systems, as well as through fuel combustion processes; (iii) The (net) exports of reactive nitrogen; and (iv) Where relevant, the change in the amounts of  $N_r$  that become available in the short term as a result of stock changes (soils, groundwater).

In this context, the importance of the reduction of  $NO_3^-$  to  $N_2$  in waters, soils and wastewater treatment plants should be noted. Denitrification is the only (!) process within the biosphere by which reactive nitrogen can be converted to the molecular form. Surprisingly, there have been relatively few investigations of the extent of denitrification in soils and groundwater, in surface waters, and in waste, and the factors influencing it. Water management experts in Germany regularly draw attention to the lack of knowledge about the denitrification capacity in the unsaturated zone and in groundwater in the regions of Germany (Bergmann et al., 2013), and whether similar rates of underground nitrate reduction can be expected in the longer term (cf. UBA, 2017c). The importance of denitrification further highlighted if the depletion of nitrogen stocks in utilised agricultural land – an estimated  $500 \text{ kt N a}^{-1}$  – is also taken into account. In view of the considerable uncertainty involved, this value has not been included in the nitrogen budget.

The structure of the pools and sub-pools of a National Nitrogen Budget proposed by the ECE (2013) was based on the UNFCCC system for reporting on greenhouse gas emissions. In the light of our experience, this only seems to be of limited use for the registration of national nitrogen flows. The allocation of N-flows to pools according to ECE (2013) is based primarily on the economic sectors in which activities take place. We would find it more appropriate to structure the budget on the basis of the material flows and/or the key N-turnover processes. Some examples illustrate this: (i) All material flows involving the combustion of fuels containing nitrogen (e.g. fossil fuels, wood, sludge, waste, bone meal) should be classified in a process-related pool “Fuel” (instead of separating combustion processes between the sub-pools “Energy Conversion”, “Material World”, “Solid Waste”, etc.). (ii) The material flows between “Agriculture”, “Food and Feed Processing” and “Human Body (and pets)” are all much more closely related with each other than with the other sub-pools in the two pools “Material and Products in Industry” and “Humans and Settlements”. These nitrogen flows can be combined in a



single pool “Agriculture and Food”. (iii) Similarly, the material flows in consumer goods production from the initial ammonia synthesis through to the consumer commodities could be considered together in a “Goods production and consumption” pool.

As a further simplification, the nitrogen flows could be divided between the Biosphere and the Technosphere.

In the Biosphere (with atmosphere, hydrosphere, agrosphere, human nutrition) the N-flows primarily involve biomass or the inorganic N-products resulting from degradation. This sector is the source of almost all environmentally relevant N emissions which impact on terrestrial ecosystems ( $\text{NH}_3$ -concentration in air, N-deposition on soils), groundwater ( $\text{NO}_3^-$  concentration), surface waters ( $\text{N}_{\text{tot}}$  load), climate ( $\text{N}_2\text{O}$  emissions), and human health ( $\text{N}_2\text{O}$  concentration).

In the Technosphere, nitrogen flows are primarily contained in technical goods. It is not possible at present to accurately depict the internal conversions or the N-flows associated with goods production, but this is not absolutely necessary. For our purposes, it would seem sufficient to register the transfers of reactive nitrogen from the technosphere to the biosphere, which mainly take place in the form of N-mineral fertilisation, discharges from wastewater, the material recycling of sludge, and atmospheric deposition.

Information about the quantities, sources and the fate of (potentially) polluting N-compounds is essential for the formulation of environmental policies and programmes. The environmental impacts of reactive nitrogen differ for the individual N-species ( $\text{NO}_3^-$ ,  $\text{NH}_3/\text{NH}_4^+$ ,  $\text{N}_2\text{O}$ ,  $\text{NO}$ ,  $\text{NO}_2$ ) and will also depend on which vulnerable sector is considered (e.g. human health, climate, groundwater, surface waters, or vegetation with low nitrophily). The environmental impacts of N-flows cannot be expressed solely in terms of kilotonnes N per year. A differentiated interpretation must also take into account the critical levels for each sector. An approach for the integrated evaluation of the emissions of reactive nitrogen at the national level has been developed with the DESTINO nitrogen indicator for Germany (see DESTINO Report 1; UBA 2020).

A nitrogen flow scheme can also depict the processes by means of which nitrogen is converted from one N-species to another, including the conversion rates. This knowledge can be used to develop differentiated strategies for the reduction of emissions and depositions of reactive nitrogen across sectors and environmental media. An interesting future task could be to “dynamise” the national N-flow scheme, i.e. to integrate the reaction of the system to interventions at individual points. This would make it possible to estimate the measures needed to achieve given environmental goals, and to predict possible trade-offs.

We have not compared our results with those of other countries, or with earlier work on N-flows in Germany (UBA 2009a, 2009b, 2015) because the differences in methodologies limit the comparability both between one another and with our results. Internationally, NNBS may come to represent an instrument for assessing the contribution of individual countries to the global nitrogen problem, and possibly also for assessing the effectiveness of reduction measures. However, this would require the statistical data on N-flows between the countries to be of a comparable quality. It does not seem likely that reliable estimates of the extent of denitrification will be available in the foreseeable future, so that it will probably not be possible to present fully balanced national nitrogen budgets. The difference between the valid estimates for nitrogen inflows and outflows is in part denitrified, and the remainder increases the amount of reactive nitrogen in the environment.



## 15 Acknowledgements

We are grateful to numerous individuals and institutions for providing data, information, and comments, including (in alphabetical order of the institutions):

Dr Talhammer, AlzChem Group AG

Uwe Maaßen, Deutscher Braunkohlen-Industrie-Verein e.V. (DEBRIV)

Jonatan Prosenjak, Federal Office for Economic Affairs and Export Control (BAFA)

Simone Böhmerle, Bundesinformationszentrum Landwirtschaft (BZL) in der Bundesanstalt für Landwirtschaft und Ernährung (BLE)

Sebastian Seiwert, Bundesnetzagentur für Elektrizität, Gas, Telekommunikation, Post und Eisenbahnen (BNetzA)

Dr Martin Ruhrberg, Bundesverband der Energie- und Wasserwirtschaft e.V. (BDEW)

Dr Nelli Elizarov, Dietrich Klein, Bundesverband der deutschen Bioethanolwirtschaft e.V. (BDBE)

Peter Radewahn, Deutscher Verband Tiernahrung (DVT)

Dr Arno Becker, Dietmar Kemnitz, Fachagentur Nachwachsende Rohstoffe e.V. (FNR)

Dr Alexander Vogel, Forschungsdatenzentrum der Statistischen Ämter der Länder (FDZ), Standort Kiel/Hamburg

Dr Christoph Steinbach, Gesellschaft für Chemische Technik und Biotechnologie e.V. (DECHEMA)

Dr Sven Hartmann, Industrieverband Agrar (IVA)

Thomas Gauger, Institute of Navigation (INS), University of Stuttgart

Dr Andreas Prüeß, Landesanstalt für Umwelt Baden-Württemberg (LUBW)

MWV-Team, Association of the German Petroleum Industry (MWV)

Harald Niemann, Servicegesellschaft Tierische Nebenprodukte (STN)

Dr Hartmut Höh, Mandy Schmidt, Christiane Stute, Britta Thorenz, Federal Statistical Office

Prof Alfons Kather, Technical University Hamburg-Harburg

Dr Axel Don, Dr Reinhard Well, Thünen Institute

Rolf Beckers, Wolfgang Butz, Markus Geupel, Markus Gleis, Patric Heidecke, Kristina Juhrich, Volker

Mohaupt, Harald Niemann, Sue-Martina Starke, Umweltbundesamt (UBA)

Angelika Becker, Verband der Chemischen Industrie (VCI)

Sarah Röhlen, Verband der Humus- und Erdenwirtschaft e. V. (VHE)

Dr Andreas Wecker, VGB Power Tech e.V.

Michael Beeck, Yara Germany.

We also wish to thank the following graduate and undergraduate students for their contributions:

Dennis Bredlau, Romina Gehler, Lucas Mettler und Sonja Steegmüller (University of Giessen).

## 16 Literature

- AGEB (2015): Vorwort zu den Energiebilanzen für die Bundesrepublik Deutschland. Arbeitsgemeinschaft Energiebilanzen e.V. (AGEB), Berlin.
- AGEB (2017): Auswertungstabellen zur Energiebilanz Deutschland 1990 bis 2016. Arbeitsgemeinschaft Energiebilanzen e.V. (AGEB), Berlin.
- Agriculture and Agri-Food Canada (2018): Sector Trend Analysis. Pet Food Trends in Germany. ([www.agr.gc.ca/resources/prod/Internet-Internet/MISB-DGSIM/ATS-SEA/PDF/6906-eng.pdf](http://www.agr.gc.ca/resources/prod/Internet-Internet/MISB-DGSIM/ATS-SEA/PDF/6906-eng.pdf), accessed 03.02.2018).
- Andreae H, Eickenscheidt N, Evers J, Grüneberg E et al. (2016): Stickstoffstatus und dessen zeitliche Veränderungen in Waldböden. In: Wellbrock N, Bolte A, Flessa H (Eds): Dynamik und räumliche Muster forstlicher Standorte in Deutschland. Ergebnisse der Bodenzustandserhebung im Wald 2006 bis 2008. Thünen-Report 43, 135-180.
- Arnold S (2015): Bereitstellung harmonisierter Landnutzungs- und Landbedeckungsstatistiken. Statistisches Bundesamt, Wirtschaft und Statistik 2015/2, 67-79.
- Awb (2018): Abfallwirtschaftsbetrieb Böblingen. Die Kreismülldeponie Sindelfingen von 1959 – 2016. ([www.irabb.de/site/LRA-BB-Desktop/get/params\\_E-1188838226/13467764/Brosch%C3%BCre%20f%C3%BCr%20web%20-%203459.pdf](http://www.irabb.de/site/LRA-BB-Desktop/get/params_E-1188838226/13467764/Brosch%C3%BCre%20f%C3%BCr%20web%20-%203459.pdf), accessed 28.06.2018).
- Bach M, Godlinski F, Greef JM (2011): Handbuch Berechnung der Stickstoffbilanz für die Landwirtschaft in Deutschland Jahre 1990 – 2008. Berichte aus dem Julius Kühn-Institut 159, 28 S.
- Bach M, Häußermann U (2016): Berechnung von Stickstoff-Flächenbilanzen für die Landwirtschaft in Deutschland mit Regional-gliederung Kreise und kreisfreie Städte. Jahre 2003 bis 2014. Wettenberg, 2016.
- Beisecker R, Blankenburg H, Bittersohl J, Evers J et al. (2012): Diffuse Stoffausträge aus Wald und naturnahen Nutzungen. LAWA-Bund/Länder-Arbeitsgemeinschaft Wasser, Abschlussbericht. Kassel/Göttingen.
- Bergmann A, Dietrich P, van Straaten L, Frabko U, van Berk W, Kiefer J (2013): Konsequenzen nachlassenden Nitrat-abbauvermögens in Grundwasserleitern. Deutscher Verein Gas- u. Wasserfach (DVGW), Bonn (Abschlussbericht).
- BGK (2006): Organische Düngung. Grundlagen der guten fachlichen Praxis. Bundesgütegemeinschaft Kompost e.V (BGK).
- BMEL (2015): Statistisches Jahrbuch über Ernährung, Landwirtschaft und Forsten der Bundesrepublik Deutschland 2015. Hrsg.: Bundesministerium für Ernährung und Landwirtschaft (BMEL). Landwirtschaftsverlag, Münster-Hiltrup.
- BMEL (2016): Statistisches Jahrbuch über Ernährung, Landwirtschaft und Forsten der Bundesrepublik Deutschland 2016. Hrsg.: Bundesministerium für Ernährung und Landwirtschaft (BMEL). Landwirtschaftsverlag, Münster-Hiltrup.
- BMEL (2018): Flächenbilanz, Stallbilanz und Nährstoffbilanz insgesamt der Landwirtschaft in Deutschland 1992-2016. Bundesministerium für Ernährung und Landwirtschaft (BMEL) (online: [www.bmel-statistik.de/landwirtschaft/statistischer-monatsbericht-des-bmel-kapitel-a-landwirtschaft](http://www.bmel-statistik.de/landwirtschaft/statistischer-monatsbericht-des-bmel-kapitel-a-landwirtschaft)).
- BMUB (2017): Stickstoffeintrag in die Biosphäre. Erster Stickstoff-Bericht der Bundesregierung. Bundesministerium für Umwelt, Bau, Naturschutz und Reaktorsicherheit. 31 S.
- Boring LR, Swank WT, Waide JB, Henderson GS (1988): Sources, fates, and impacts of nitrogen inputs to terrestrial ecosystems: review and synthesis. *Biogeochemistry* 6(2), 119–159.
- Borken W, Matzner E (2004): Nitrate leaching in forest soils: an analysis of long-term monitoring sites in Germany. *Journal of Plant Nutrition and Soil Science* 167, 277-283.
- Builtjes PJH, Hendriks E, Koenen M, Schaap M, Banzhaf S, Kerschbaumer A, Gauger T, Nagel HD, Scheuschner T, Schlutow A (2011): Erfassung, Prognose und Bewertung von Stoffeinträgen und ihren Wirkungen in Deutschland (in German). MAPESE-Project: Modeling of Air Pollutants and Ecosystem Impact. Umweltbundesamt (UBA), Dessau, UBA-Texte 38/2011.
- BMU (2002): BMU-/LAGA Hinweise und Erläuterungen zu Anhang 51 Abwasserverordnung: Oberirdische Ablagerung von Abfällen ([www.umwelt-online.de/regelwerk/wasser/abw\\_vo/an51e.htm](http://www.umwelt-online.de/regelwerk/wasser/abw_vo/an51e.htm), accessed 28.06.2018).
- BfG (2013): Frachtberechnungsmodul Prioritäre Stoffe. Unter Mitarbeit von Holger Haase. Bundesanstalt für Gewässerkunde (BfG), Koblenz.

- Bundesgütegemeinschaft Kompost (2017): Auswertung der gütegesicherten Kompostanalysen 2017. ([www.kompost.de/fileadmin/user\\_upload/Dateien/Zahlen/Kompost\\_D\\_2017.pdf](http://www.kompost.de/fileadmin/user_upload/Dateien/Zahlen/Kompost_D_2017.pdf), accessed 5.4.2018).
- Callesen I, Borken W, Kalbitz K, Matzner E (2007): Long-term development of nitrogen fluxes in a coniferous ecosystem: Does soil freezing trigger nitrate leaching? *J Plant Nutrition Soil Science* 170, 189–196.
- Cleveland CC, Townsend AR, Schimel DS, Fisher H, Howarth RW, Hedin LO, Perakis SS et al. (1999): Global patterns of terrestrial biological nitrogen (N<sub>2</sub>) fixation in natural ecosystems. *Global Biogeochemical Cycles*, 623–645.
- Copernicus (2015): GIO Land Monitoring 2011–2013 in the framework of regulation (EU) No 911/2010. Pan-EU Component. Grant Agreement 3541/B2012/RO-GIO/EEA.55080. Final Report Germany (unpublished).
- DESTATIS (versch. J.): Flächenerhebung nach Art der tatsächlichen Nutzung Deutschland. Statistisches Bundesamt, Wiesbaden.
- DESTATIS (2008): Klassifikation der Wirtschaftszweige. Statistisches Bundesamt, Wiesbaden.
- DESTATIS (2011): Bodenbearbeitung, Bewässerung, Landschaftselemente. Erhebung über landwirtschaftliche Produktionsmethoden (ELPM). Fachserie 3, Heft 5. Statistisches Bundesamt, Wiesbaden.
- DESTATIS (2012a): Abfallentsorgung 2010. Fachserie 19 Reihe 1. Statistisches Bundesamt, Wiesbaden.
- DESTATIS (2012b): Abfallaufkommen nach Wirtschaftszeigen gemäß EU-Abfallstatistikverordnung 2010. Statistisches Bundesamt, Wiesbaden.
- DESTATIS (2013): Abfallentsorgung 2011. Fachserie 19 Reihe 1. Statistisches Bundesamt, Wiesbaden.
- DESTATIS (2014a): Abfallentsorgung 2012. Fachserie 19 Reihe 1. Statistisches Bundesamt, Wiesbaden.
- DESTATIS (2014b): Abfallaufkommen nach Wirtschaftszeigen gemäß EU-Abfallstatistikverordnung 2012. Statistisches Bundesamt, Wiesbaden
- DESTATIS (2015a): Außenhandel. Zusammenfassende Übersichten für den Außenhandel (Endgültige Ergebnisse). Jahr 2014. Fachserie 7, Reihe 1, Statistisches Bundesamt, Wiesbaden.
- DESTATIS (2015b): Abfallentsorgung 2013. Fachserie 19 Reihe 1. Statistisches Bundesamt, Wiesbaden.
- DESTATIS (2015c): Öffentliche Wasserversorgung und öffentliche Abwasserentsorgung. Öffentliche Abwasserbehandlung und -entsorgung 2013. Fachserie 19 Reihe 2.1.1. Statistisches Bundesamt, Wiesbaden.
- DESTATIS (2016): Abfallentsorgung 2014. Fachserie 19 Reihe 1. Statistisches Bundesamt, Wiesbaden.
- DESTATIS (2017a): Produzierendes Gewerbe 2016. Fachserie 4, Reihe 3.1. Statistisches Bundesamt, Wiesbaden.
- DESTATIS (2017b): Abwasserbehandlung – Klärschlamm. Ergebnisbericht 2013/2014. Statistisches Bundesamt, Wiesbaden.
- DESTATIS (2017c): Abfallbilanz. Statistisches Bundesamt, Wiesbaden.
- DESTATIS (2018): Abfallentsorgung 2016. Fachserie 19, Reihe 1. Statistisches Bundesamt, Wiesbaden,
- Dise NB, Rothwell JJ, Gauci V, van der Salm C, de Vries W (2009): Predicting dissolved inorganic nitrogen leaching in European forests using two independent databases. *Science of the Total Environment*, 1789–1808.
- Doering OC III et al. (2011): Reactive Nitrogen in the United States: An Analysis of Inputs, Flows, Consequences, and Management Options: A Report of the EPA Science Advisory Board. EPA-SAB-11-013.
- Don A (2019). Anmerkungen zur Interpretation der Bodenzustandserhebung Landwirtschaft. Thünen-Institut, Braunschweig (e-mail, 07.01.2019).
- DWA (2011): Die Stickstoffbilanz im kommunalen Abwasser, Leitfaden Nr. 2-14: Betrieb von Abwasseranlagen. Deutsche Vereinigung für Wasserwirtschaft, Abwasser und Abfall e. V. (DWA), Landesverband Bayern, Munich.
- DWA (2017): 29. Leistungsvergleich kommunaler Kläranlagen, DWA-Arbeitsgruppe BIZ-1.1. Kläranlagen-Nachbarschaften. Deutsche Vereinigung für Wasserwirtschaft, Abwasser und Abfall e. V. (DWA), Hennef.
- EEA (2013) EMEP/EEA Air Pollutant Inventory Guidebook 2013. Technical guidance to prepare national emission inventories. European Environment Agency (EEA). Publication Office of the European Union, Luxembourg.

- ECE (2013): Guidance document on national nitrogen budgets. Economic Commission for Europe (ECE), Executive Body for the Convention on Long-range Transboundary Air Pollution, ECE\_EB.AIR\_119, 12 p. ([www.unece.org/fileadmin/DAM/env/documents/2013/air/eb/ECE\\_EB.AIR\\_119\\_ENG.pdf](http://www.unece.org/fileadmin/DAM/env/documents/2013/air/eb/ECE_EB.AIR_119_ENG.pdf), accessed 08.11.2017).
- ECE (2016): Detailed Annexes to ECE/EB.AIR/119 – Guidance document on national nitrogen budgets. Editor: Wilfried Winiwater and Expert Panel on Nitrogen Budgets. Economic Commission for Europe (ECE), Executive Body for the Convention on Long-range Transboundary Air Pollution. ([www.clrtap-tfrn.org/sites/clrtap-tfrn.org/files/documents/EPNB\\_new/EPNB\\_annex\\_20160921\\_public.pdf](http://www.clrtap-tfrn.org/sites/clrtap-tfrn.org/files/documents/EPNB_new/EPNB_annex_20160921_public.pdf), accessed 08.11.2017).
- EEA (2014): Versiegelungsgrade in der Auflösung 100 m x 100 m und 20 m x 20 m für die Jahre 2006 und 2009, 2014. European Environment Agency (EEA).
- EMEP (2016): Datensatz: Nasse und trockene atmosphärische Deposition von oxidiertem und reduziertem Stickstoff für den Zeitraum 2012-2014. EMEP Meteorological Synthesizing Centre - West (EMEP/MS-C-West). ([webdab.emep.int/Unified\\_Model\\_Results/](http://webdab.emep.int/Unified_Model_Results/), accessed 15.01.2016)
- EMEP (2017): Transboundary particulate matter, photo-oxidants, acidifying and eutrophying components. Status Report 1/2017. Joint MSC-W & CCC & CEIP Report ([emep.int/publ/reports/2017/EMEP\\_Status\\_Report\\_1\\_2017.pdf](http://emep.int/publ/reports/2017/EMEP_Status_Report_1_2017.pdf), accessed 10.03.2018)
- Eurostat (o.J.): In der PRODCOM-Liste 2017 enthaltene Codes der Kombinierten Nomenklatur 2017 mit Angabe der entsprechenden PRODCOM-Codes ([circabc.europa.eu/webdav/CircaBC/ESTAT/prodcom/Library/the\\_list/2017%20List/CN\\_PRC\\_DE\\_2017.pdf](http://circabc.europa.eu/webdav/CircaBC/ESTAT/prodcom/Library/the_list/2017%20List/CN_PRC_DE_2017.pdf), accessed 8.6.2018).
- FDZ (2013): Statistik der öffentlichen Abwasserbehandlung. Merkmalsträger „Abwasserbehandlungsanlage“. Forschungsdatenzentrum der Statistischen Ämter des Bundes und der Länder (FDZ), Bezugsjahr 2010. ([dok.fdz-metadata.de/3/32/322/322130/erheb/200700/Merkmale\\_Abwasserbehandlungsanlage\\_2007.pdf](http://dok.fdz-metadata.de/3/32/322/322130/erheb/200700/Merkmale_Abwasserbehandlungsanlage_2007.pdf), accessed 03.09.2014).
- Fichtner W, Karl U, Hartel, R, Balussou D (2011): Fortschreibung der Emissionsfaktoren für Feuerungs- und Gasturbinenanlagen nach 13./17. BImSchV und TA Luft. Bericht zum Forschungsvorhaben des Umweltbundesamtes (FKZ 3708 42 301). Deutsch-Französisches Institut für Umweltforschung (DFIU) und Europäisches Institut für Energieforschung (EIFER).
- FNR (2018): Anbau und Verwendung nachwachsender Rohstoffe in Deutschland. Fachagentur Nachwachsende Rohstoffe (FNR,), Gülzow, 17 S. ([www.fnr-server.de/ftp/pdf/berichte/22004416.pdf](http://www.fnr-server.de/ftp/pdf/berichte/22004416.pdf), accessed 12.2.2018).
- Friedrich R et al. (2007): NatAir - Improving and applying methods for the calculation of natural and biogenic emissions and assessment of impacts to the air quality. Final Activity Report, Sixth Framework Programme, FP6-2003-SSP-3, Contract 513699 ([natair.ier.uni-stuttgart.de/NatAir\\_Final\\_Activity\\_Report.pdf](http://natair.ier.uni-stuttgart.de/NatAir_Final_Activity_Report.pdf), accessed 09.05.2018).
- Fritsche UR, Leuchtner J, Matthes FC, Rausch L, Simon KH (1994): Globales Emissions-Modell Integrierter Systeme (GEMIS), Vers. 2.1. Aktualisierter, erweiterter Endbericht. Öko-Institut (Institut f. angewandte Ökologie), Freiburg.
- Fritsche UR, Rausch L (2007): Umwelteffekte der Strom- und Wärmebereitstellung sowie Kraftstoffnutzung: Zeitreihen 1990 bis 2004. Öko-Institut (Institut für angewandte Ökologie e.V.), Freiburg.
- Fuchs F, Scherer U, Wander R, Behrendt H, Venohr M, Opitz D, Hillenbrand T, Marscheider-Weidemann F (2010): Berechnung von Stoffeinträgen in die Fließgewässer Deutschlands mit dem Modell MONERIS. Nährstoffe, Schwermetalle und Polyzyklische aromatische Kohlenwasserstoffe. Umweltbundesamt, UBA-Texte 45/2010.
- Fuchs S, Toshovski S, Wander R, Kittlaus S, Reid L (2016): Aktualisierung der Stoffeintragsmodellierung (Regionalisierte Pfadanalyse) für die Jahre 2012 bis 2014. Karlsruher Institut für Technologie, Institut für Wasser und Gewässerentwicklung, Bereich Siedlungswasserwirtschaft und Wassergütewirtschaft, Karlsruhe (unveröffentlicht).
- Fuchs S, Weber T, Wander R, Toshovski S, Kittlaus S, Reid L, Bach M, Klement L, Hillenbrand T, Tettenborn F (2017a): Effizienz von Maßnahmen zur Reduktion von Stoffeinträgen. Umweltbundesamt, UBA-Texte 05/2017.
- Fuchs S, Kaiser M, Kiemle L, Kittlaus S, Rothvoß S, Toshovski S et al. (2017b): Modeling of Regionalized Emissions (MoRE) into Water Bodies. An Open-Source River Basin Management System. *Water* 9(4).
- Galloway JN, Aber JD, Erisman JW, Seitzinger SP, Howarth RW, Cowling EB, Cosby JB (2003): The Nitrogen Cascade. *BioScience* 53(4), 341–356.

- Gauger T, Haenel H D, Rösemann C, Dämmgen U, Bleeker A et al. (2008): National Implementation of the UNECE Convention on Long-range Transboundary Air Pollution (Effects) - Part 1: Deposition Loads: Methods, modelling and mapping results. Umweltbundesamt (UBA), Dessau-Roßlau, UBA-Texte 38/08.
- Gauger T (2018): Thomas Gauger, Institute of Navigation, INS, Universität Stuttgart, written communication. 9.5.2018.
- GU B, Ju X, Chang J, Ge Y, Vitousek PM (2015): Integrated reactive nitrogen budgets and future trends in China. PNAS 112, 8792-8797.
- Gutknecht JLM, Goodman RM, Balsler TC (2006): Linking soil process and microbial ecology in freshwater wetland ecosystems. Plant Soil 289, 17-34.
- Heldstab J, Reutimann J, Biedermann R, Leu D (2010): Stickstoffflüsse in der Schweiz. Stoffflussanalyse für das Jahr 2005. Bundesamt für Umwelt, Bern.
- Häußermann U, Bach M, Klement L, Breuer L (2019): Stickstoff-Flächenbilanzen für Deutschland mit Regionalgliederung Bundesländer und Kreise – Jahre 1995 bis 2017 Umweltbundesamt (UBA), Dessau-Roßlau, UBA-Texte 131/2019.
- Hutchings NJ, Nielsen OK, Dalgaard T, Mikkelsen MH, Børgesen CD et al. (2014): A nitrogen budget for Denmark; developments between 1990 and 2010, and prospects for the future. Environmental Research Letters 9, 115012.
- Industrieverband Heimtierbedarf (2018): Der deutsche Heimtiermarkt. Struktur und Umsatzdaten. ([www.ivh-online.de/typo3temp/secure\\_downloads/680/0/abcb239cb0db06f3b7ee6da01e52babd2b0bbb85/Der\\_Deutsche\\_Heimtiermarkt\\_2014.pdf](http://www.ivh-online.de/typo3temp/secure_downloads/680/0/abcb239cb0db06f3b7ee6da01e52babd2b0bbb85/Der_Deutsche_Heimtiermarkt_2014.pdf), accessed 27.01.2018).
- IVA (2017): Wichtige Zahlen Düngemittel 2016-2017. Industrieverband Agrar (IVA), Frankfurt a.M.
- IPCC (2006): 2006 IPCC Guidelines for National Greenhouse Gas Inventories. Overview. Eds.: Penman J, Gytarsky M, Hiraishi T, Irving W, Krug T. Intergovernmental Panel on Climate Change (IPCC).
- Jacobs A, Flessa H, Don A, Heidkamp A, Prietz R, Dechow R et al. (2018): Landwirtschaftlich genutzte Böden in Deutschland – Ergebnisse der Bodenzustandserhebung. Thünen Report 64, Thünen-Institut, Braunschweig.
- Jochem D, Weimar H, Bösch M, Mantau U, Dieter M (2015): Estimation of wood removals and fellings in Germany: a calculation approach based on the amount of used roundwood. Eur J Forest Res 134(5), 869-888.
- Keller R, Wendland F (2013): Berechnung der potenziellen Nitratkonzentrationen im Sickerwasser auf Kreisebene für die Bundesrepublik Deutschland - Teilleistung im Rahmen des BMBF Forschungs- und Entwicklungsvorhabens "Wasserflüsse in Deutschland" (FKZ 033L056). Forschungszentrum Jülich.
- Kiese R, Heinzeller C, Werner C, Wochele S, Grote R, Butterbach-Bahl K (2011): Quantification of nitrate leaching from German forest ecosystems by use of a process oriented biogeochemical model. Environmental Pollution, 3204-3214.
- Leip A, Achermann B, Billen G, Bleeker A et al. (2011): Integrating nitrogen fluxes at the European scale. In: Sutton M, Howard C, Erismann JW, Billen et al. (eds.): The European Nitrogen Assessment. Cambridge University Press, Cambridge, 345-376.
- Macdonald JA, Dise NB, Matzner E, Armbruster M, Gundersen P, Forsius M (2002): Nitrogen input together with ecosystem nitrogen enrichment predict nitrate leaching from European forests. Global Change Biology 8, 1028-1033.
- Mielenz H, Dierer M (2018): Stickstoff-Bilanzen für die Landwirtschaft in Deutschland Zeitreihe 1990 bis 2016 – Zusammenfassung und Anmerkungen zum Bilanzjahr 2016. Bericht des Julius Kühn-Institut, Bundesforschungsinstitut für Kulturpflanzen, Institut für Pflanzenbau und Bodenkunde, Braunschweig.
- Niemann H (2009): Servicegesellschaft tierische Nebenprodukte mbH, Bonn (oral communication, 3.12.2009).
- Niemann H (versch. J.): Statistik der Verarbeitung tierischer Nebenprodukte [Jahr]. Tierische Nebenprodukte Nachrichten, Bonn.
- NLFB (2005): EG-WRRRL – Bericht 2005, Grundwasser, Methodenbeschreibung. Niedersächs. Landesamt f. Ökologie und Bezirksregierung Hannover ([cdl.niedersachsen.de/blob/images/C38304492L20.pdf](http://cdl.niedersachsen.de/blob/images/C38304492L20.pdf), accessed 28.6.2018).
- OECD (2017): OECD Health Statistics 2017. Definitions, Sources, Methods. Tobacco consumption in grams per capita (age 15+). ([stats.oecd.org/fileview2.aspx?IDFile=8e59b835-8196-426e-9297-15bc1dab652c](http://stats.oecd.org/fileview2.aspx?IDFile=8e59b835-8196-426e-9297-15bc1dab652c), accessed 17.12.2017).
- Oehmichen K, Dunger K, Steuk J, Stümer W, Riedel T (2011): Weitere detaillierte methodische Beschreibungen für die Quell-/Senkenkategorie Landnutzungsänderung und Forstwirtschaft (5) Wälder (5.A.) [Kap.19.5.1]. In: Berichterstattung unter der Klimarahmenkonvention der Vereinten Nationen und dem Kyoto-Protokoll 2011: Nationaler



Inventarbericht zum Deutschen Treibhausgasinventar 1990 – 2009. Umweltbundesamt, Dessau-Roßlau, Climate change 11/2011, 637-649.

Öko-Institut (1994): Umweltanalyse von Energie-, Transport- und Stoffsystemen: Gesamt-Emissions-Modell integrierter Systeme (GEMIS) Version 2.1 - erweiterter und aktualisierter Endbericht. Institut für angewandte Ökologie e.V (Öko-Institut.), pub. Hessisches Ministerium für Umwelt, Energie und Bundesangelegenheiten (HMUEB), Wiesbaden.

Osterburg B (2015): Ammoniak in der (Gas)Emissionsberichterstattung. Vortrag 1. Bund-Länder-Fachgespräch Stickstoffbilanz (FGNB) 5./6.5.2015, Stuttgart. Thünen-Institut, Braunschweig.

Parravicini V, Valkova T, Haslinger J, Saracevic E et al. (2015): Reduktionspotenzial bei den Lachgasemissionen aus Kläranlagen durch Optimierung des Betriebes (ReLaKO), Umweltbundesamt, Vienna.

Prietzl J, Zimmermann L, Schubert A, Christophel D (2016): Organic matter losses in German Alp forest soils since the 1970s most likely caused by warming. Nature Geoscience, 13 June 2016.

Regulation (EC) No 1893/2006 of the European Parliament and of the Council of 20 December 2006 establishing the statistical classification of economic activities NACE Revision 2 and amending Council Regulation (EEC) No 3037/90 as well as certain EC Regulations on specific statistical domains Text with EEA relevance.

Rentz O, Gütling K, Karl U (2002): Erarbeitung der Grundlagen für das BVT-Merkblatt Großfeuerungsanlagen im Rahmen des Informationsaustauschs nach Art. 16 (2) IVU-Richtlinie. Inst. f. Umweltforschung, Univ. Karlsruhe (TH), for UBA, Research report 20046317.

Rösemann C, Haenel HD, Dämmgen U, Freibauer A, Döring U, Wulf S, Eurich-Menden B, Döhler H, Schreiner C, Osterburg B (2017): Calculations of gaseous and particulate emissions from German agriculture 1990 – 2015. Report on methods and data (RMD) Submission 2017. Berechnung von gas- und partikelförmigen Emissionen aus der deutschen Landwirtschaft 1990 – 2015. Report zu Methoden und Daten (RMD), Berichterstattung 2017. Thünen Report 46.

Ruhrberg M (2018): Einsatz von Ammoniak zur Rauchgasreinigung in Kraftwerken. Dr. Martin Ruhrberg, Bundesverband der Energie- und Wasserwirtschaft e.V. (BDEW) (written communication, 12.4.2018).

Salm van der CW, de Vries GJ, Reinds, Diese NB (2007): N leaching across European forests/ Derivation and validation of empirical relationships using data from intensive monitoring plots. Forest Ecology Management 238, 81-91.

Salomon M, Schmid E, Volkens A, Hey C, Holm-Müller K, Foth K (2016): Towards an integrated nitrogen strategy for Germany. Environmental Science Policy 55, 158-166.

Schaap M, Kruit RW, Hendriks C, Kranenburg R, Segers A, Bultjes P, Banzhaf S (2017): Modelling and assessment of acidifying and eutrophying atmospheric deposition to terrestrial ecosystems (PINETI-2) - Part I: Atmospheric deposition to German natural and semi-natural ecosystems during 2009, 2010 and 2011. Umweltbundesamt (UBA), Dessau-Rosslau, UBA-Text 62/2017.

Schaap M, Banzhaf S, Hendriks C, Kranenburg R, Kuenen J, Nagel HD, Schlutow A, Segers A et al. (2018): PINETI-III: Modellierung und Kartierung atmosphärischer Stoffeinträge von 2000 bis 2015 zur Bewertung der ökosystem-spezifischen Gefährdung von Biodiversität in Deutschland. Umweltbundesamt (UBA), Dessau-Roßlau (vorläufige Fassung für den Kartendienst des Umweltbundesamtes zu den Hintergrundbelastungsdaten Stickstoff, July 2018).

SRU (2015): Stickstoff: Lösungsstrategien für ein drängendes Umweltproblem. Sachverständigenrat für Umweltfragen (SRU), Sondergutachten.

StickstoffBW (2017): Klärung der Anforderungen an die Stickstoffbilanzierung - Grundlagen und Methodik der Critical Levels, Critical Loads und Critical Surplus zur flächendeckenden Bewertung des Stickstoffhaushalts (CS-Bericht 2017). Bund-Länder-Fachgespräch Stickstoffbilanz (FGNB), Fachdokumentendienst Umweltbeobachtung, ID U26-S7-N17, Karlsruhe.

Sutton MA, Dragosits U, Tang YS, Fowler D (2000): Ammonia emissions from non-agricultural sources in the UK. Atmospheric Environment 3(6), 855-869.

Sutton MA, Howard CA, Erismann JW, Billen G, Bleeker A, Grennfelt P, van Grinsven H, Grizzetti B (2011): The European Nitrogen Assessment: Sources, Effects and Policy Perspectives. Cambridge University Press.

Thünen-Institut (2015): Projekt Einschlagsrückrechnung. ([www.thuenen.de/index.php?id=2404&L=0](http://www.thuenen.de/index.php?id=2404&L=0); accessed 17.09.2017).

Thünen-Institut (2016a): Holzeinschlag und Rohholzverwendung. Datentabelle. ([www.thuenen.de/de/wf/zahlen-fakten/produktion-und-verwendung/holzeinschlag-und-rohholzverwendung/](http://www.thuenen.de/de/wf/zahlen-fakten/produktion-und-verwendung/holzeinschlag-und-rohholzverwendung/), accessed 09.11.2017)

- Thünen-Institut (2016b): Revisionen an Daten und Methodik zu Jochem et al. 2015. ([www.thuenen.de/de/wf/zahlen-fakten/waldwirtschaft/holzschlag-und-rohholzverwendung/](http://www.thuenen.de/de/wf/zahlen-fakten/waldwirtschaft/holzschlag-und-rohholzverwendung/), accessed 09.11.2017).
- Thünen-Institut (2016c): Dritte Bundeswaldinventur (2012). ([bwi.info.de](http://bwi.info.de), accessed 22.11.2017).
- Tiemeyer B, Borraz EA, Augustin J, Bechtold M, Beetz S, Beyer C et al. (2016): High emissions of greenhouse gases from grasslands on peat and other organic soils. *Global Change Biology* 22(12), 4134-4149.
- UBA (2009a): Integrierte Strategie zur Minderung von Stickstoffemissionen. Umweltbundesamt (UBA), Dessau-Rosslau.
- UBA (2009b): Hintergrundpapier zu einer multimedialen Stickstoff-Emissionsminderungsstrategie. Umweltbundesamt (UBA), Dessau-Rosslau.
- UBA (2012): Optimierung der Verwertung organischer Abfälle, Materialband „Wirkungsanalyse Boden“. UBA-Texte 32/2012, 99 S.
- UBA (2015): Reaktiver Stickstoff in Deutschland - Ursachen, Wirkungen, Maßnahmen. Umweltbundesamt (UBA), Dessau-Rosslau.
- UBA (2016a): Berichterstattung unter der Klimarahmenkonvention der Vereinten Nationen und dem Kyoto-Protokoll 2016. Nationaler Inventarbericht zu Deutschen Treibhausgasinventar 1990 - 2014. Umweltbundesamt (UBA), Dessau-Rosslau, Climate Change 23/2016.
- UBA (2016b): Deutsches Schadstofffreisetzungs- und -verbringungsregister (PRTR). PRTR-Gesamtdatenbestand (as of 24.09.2015), SQLite-Datenbank. Umweltbundesamt (UBA), Dessau-Rosslau. ([www.thru.de/thrude/downloads/](http://www.thru.de/thrude/downloads/), accessed 3.3.2018).
- UBA (2017a): Indikatorenbericht, Daten zur Umwelt 2017. Umweltbundesamt (UBA), Dessau-Rosslau. ([www.umweltbundesamt.de/publikationen/daten-zur-umwelt-2017](http://www.umweltbundesamt.de/publikationen/daten-zur-umwelt-2017); accessed 7.7.2017).
- UBA (2017b): Nationale Trendtabellen für die deutsche Berichterstattung atmosphärischer Emissionen 1990 – 2015. Umweltbundesamt (UBA), Dessau-Rosslau. ([www.umweltbundesamt.de/dokument/nationale-trendtabellen-fuer-die-deutsche-2](http://www.umweltbundesamt.de/dokument/nationale-trendtabellen-fuer-die-deutsche-2), accessed 17.2.2018).
- UBA (2017c): Quantifizierung der landwirtschaftlich verursachten Kosten zur Sicherung der Trinkwasserversorgung. Umweltbundesamt (UBA), Dessau-Rosslau, UBA-texte 43/2017.
- UBA (2018a): Grenzüberschreitende Verbringung von zustimmungspflichtigen Abfällen. Zeitreihe Import nach Abfallarten. Umweltbundesamt (UBA), Dessau-Rosslau ([https://www.umweltbundesamt.de/sites/default/files/medien/2503/dokumente/zeitreihe\\_import\\_notifizierungspflichtiger\\_abfaelle\\_nach\\_abfallarten.pdf](https://www.umweltbundesamt.de/sites/default/files/medien/2503/dokumente/zeitreihe_import_notifizierungspflichtiger_abfaelle_nach_abfallarten.pdf), accessed 9.7.2018).
- UBA (2018b): Grenzüberschreitende Verbringung von zustimmungspflichtigen Abfällen. Zeitreihe Export nach Abfallarten. Umweltbundesamt (UBA), Dessau-Rosslau ([https://www.umweltbundesamt.de/sites/default/files/medien/2503/dokumente/zeitreihe\\_export\\_notifizierungspflichtiger\\_abfaelle\\_nach\\_abfallarten.pdf](https://www.umweltbundesamt.de/sites/default/files/medien/2503/dokumente/zeitreihe_export_notifizierungspflichtiger_abfaelle_nach_abfallarten.pdf), accessed 9.7.2018).
- UBA (2020): Integrated nitrogen indicator, national nitrogen target and the current situation in Germany (DESTINO report 1). Umweltbundesamt (UBA), Dessau-Rosslau, UBA-Texte (in print)
- UNFCCC (2017): National Inventory Submissions 2016, Annex I: Party GHG Inventory Submissions. Common reporting format (CRF) Tables, Germany (dated 7 Nov 2016). United Nations Framework Convention on Climate Change (UNFCCC) ([unfccc.int/national\\_reports/annex\\_i\\_ghg\\_inventories/national\\_inventories\\_submissions/items/9492.php](http://unfccc.int/national_reports/annex_i_ghg_inventories/national_inventories_submissions/items/9492.php), accessed 15.11.2017).
- VCI (2017): Chemiewirtschaft in Zahlen 2017. Verband der chemischen Industrie (VCI), Frankfurt a.M.
- Venohr M (2006): Modellierung der Einflüsse von Temperatur, Abfluss und Hydromorphologie auf Stickstoffretention in Flusssystemen. Dissertation, Humboldt-Universität, Mathematisch-Naturwissenschaftlichen Fakultät II, Berlin.
- Well R, Rösemann C, Haenel D, Flessa H (2016): Größenordnung der N<sub>2</sub>-Emissionen aus landwirtschaftlich genutzten Böden. Stellungnahme für das BMEL. Thünen-Institut, Braunschweig.
- Worrall F, Burt TP, Howden NLK, Whelan MJ (2016): The UK's total nitrogen budget from 1990 to 2020: a transition from source to sink? *Biogeochemistry* 129, 325–344.