

Interlaboratory Study

„Sieving of Marine Sediments“

Preliminary Report

(Data Evaluation)

July 2001

**Working Group on Quality Assurance
German Marine Monitoring Programme**



Federal Environmental Agency (FEA)
Laboratory for Water Analysis, II 3.6
P.O. Box 33 00 22
14191 Berlin

SUMMARY

In order to study the influence of sieving on the variability of analytical results of the determination of contaminants in marine sediments, an interlaboratory study was carried out. One of the objectives of this study was to determine the repeatability and the reproducibility of the sieving process and to give information on the comparability of the mass ratios of the different sieving fractions determined by the participants. 13 laboratories took part in the exercise and separated three freeze-dried, homogenised marine sediment samples into the fractions below and above 20 μm as well as below and above 63 μm . The mass fraction (weight percentage) of each separated fraction was to be determined. Repeatabilities between 2 % and 13 % and reproducibilities between 25 % and 75 % were obtained for mass fractions which are relevant in marine monitoring (<20 μm and < 63 μm). As a reason for the high variability of the results, the different sieving procedures applied by the participants may be discussed. However, the reproducibilities obtained in this study are comparable to those of previous intercomparison exercises. A determination of heavy metals and selected organic contaminants will be carried out in the fine sediment fractions separated by all participants to study the influence of the sieving process on the variance of the analytical results.

Table of Contents

1.	INTRODUCTION	4
2.	PREPARATION OF THE TEST MATERIALS	4
3.	INTERCOMPARISON STUDY.....	5
3.1.	Organisation.....	5
3.2.	Sieving Procedure	5
3.3.	Data Assessment.....	6
3.4.	Results	7
4.	REFERENCES.....	8

Annex 1:	List of participants in alphabetical order.....	9
Annex 2:	Example of a data report sheet.....	12
Annex 3:	Original method report sheets	15
Annex 4:	Original data	29
Annex 5:	Statistical evaluation of results.....	33

1. INTRODUCTION

Sieving of marine sediments to obtain particle size fractions < 20 µm or < 63 µm for subsequent analysis of heavy metals and/or organic contaminants is routinely carried out by marine monitoring laboratories. Generally, an analysis of contaminants in fine grained fractions is used for normalisation of analytical results to compensate for the natural heterogeneity of sediments.

Within the framework of the European QUASH Project (WorkPackage 4 „Sample handling and cofactors in relation to normalisation procedures for sediments“) the effect of normalisation procedures on the overall variability of contaminant concentrations in sediments was assessed and different methods for normalisation were compared [1,2]. According to the organisational structure of QUASH, investigations on a national or regional level should follow international intercomparison studies. To support the QUASH project, the Working Group on Quality Assurance in the German Marine Monitoring Programme (GMMP) decided to carry out an intercomparison exercise on sieving of marine sediments.

The objective this study is to determine the repeatability and the reproducibility of the sieving process and to give information on the comparability of the mass ratios of the different sieving fractions determined by the participants. In a separate part of this investigation, a variety of heavy metals and selected organic contaminants (PAH, PCB) will be determined in the separated fine fractions. In contrast to previous exercises [1,2], the analytical determinations will be carried out in one laboratory only to minimise the analytical variance. This will give information on the influence of sieving on the variability of the analytical data.

This preliminary report summarises the results of the sieving study and gives information on the repeatabilities and reproducibilities obtained for the different sediments investigated. A final report containing the additional investigations on contaminant concentrations in the separated fine fractions will be published as soon as the analytical results are available.

2. PREPARATION OF THE TEST MATERIALS

Three marine sediment samples were prepared from bulk amounts of wet sediment which were delivered to the organiser immediately after sampling (see Table 1).

Table 1: Test samples for the Interlaboratory Study „Sieving of Marine Sediments“

Sample	Origin	Sampling Date	Provider	Code
North Sea	List, Königshafen	24.07.2000	LANU	A
Elbe Estuary	?	?	BfG	B
Baltic Sea	Unterwarnow	?	IOW	C

Sediment were freeze-dried, and the fractions below 2 mm were separated. These fractions were thoroughly homogenised in a Polyethylene drum (24 hours) and bottled into 500 ml wide-

neck amber glass bottles. A preliminary test of homogeneity was carried out by determining the mass of the < 63 µm fraction with six random chosen bottles. All three sediment samples were found to be sufficiently homogeneous for the exercise.

3. INTERCOMPARISON STUDY

3.1. Organisation

Between 500 g and 1 kg (2 bottles) of each sediment (< 2 mm) were shipped to 13 laboratories (Annex 1) together with data report sheets (Annex 2) and a questionnaire referring to the applied sieving conditions. Results of all laboratories were returned to the organiser. Table 2 shows the time course of the exercise.

Table 2: Time course of the Interlaboratory Study „Sieving of Marine Sediments“

Date	Action	Remarks/Responsibility
2.5. 2001	Invitation of laboratories	Organiser
15.5.2001	Declaration of participation	Participants
16.5.2001	Closing of the list of participants	
18.5.2001	Sample dispatch	Organiser
1.6.2001	Acknowledging of sample receipt	Participants
20.7.2001	Return of sieving results and separated sediment fractions to the organiser	Participants
31.7.2001	Statistical evaluation of the sieving data – report on preliminary results	Organiser
October 2001	Determination of heavy metals in the separated sediment fractions	Organiser
Spring 2002	Determination of trace organics in the separated sediment fractions	Organiser ((financial support still open)
Summer 2002	Final report	Organiser

3.2. Sieving Procedure

Figure 1 shows a schematic diagram of the interlaboratory study. The participants were requested to perform sediment sieving according to the procedures routinely used in the laboratory. This included wet sieving procedures, particularly for the 20 µm fraction. Three replicate determinations to obtain the mass fractions below and above 20 µm (FS1, FS2) as well as below and above 63 µm (FO1, FO2) were to be carried out for each sample. Additionally, participants were requested to sent back all separated sediment fractions (below and above 20 µm and 63 µm) to the organiser for subsequent analysis of heavy metals and organic contaminants. Annex 3 gives a compilation of the procedures used by the participants for sieving of sediments.

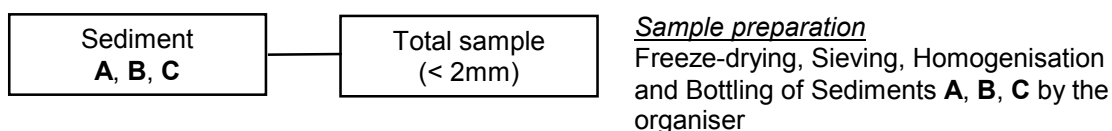

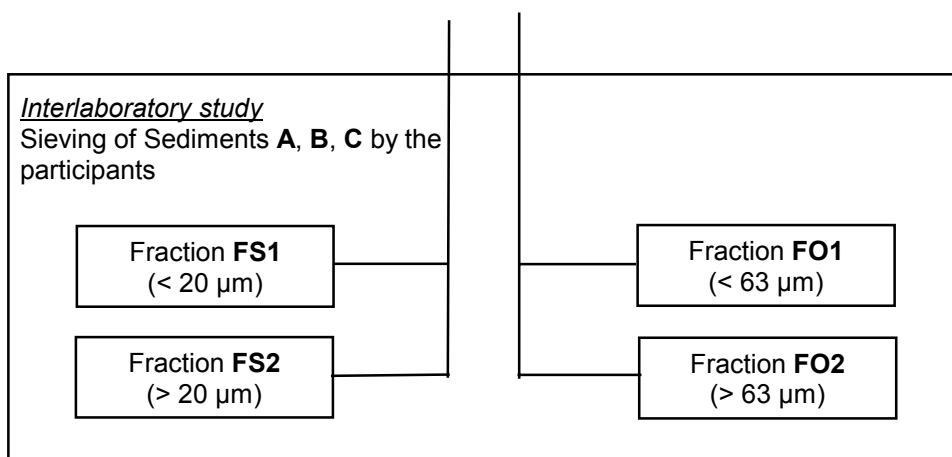

Figure 1: Scheme of the Interlaboratory Study „Sieving of Marine Sediments“

3.3. Data Assessment

The data assessment followed the ISO 5725-2 protocol implemented in the software package PROLAB2000 (Dr. Uhlig, quo data, Dresden, Germany). Table 3 shows the different steps of the data evaluation and measures taken to ensure a proper performance of the intercomparison exercise. The original data of all participants are given in Annex 4.

Table 3: Measures and actions taken to ensure reliable performance of the Interlaboratory Study „Sieving of Marine Sediments“

Action	Laboratory
Assignment of laboratory codes before sample dispatch to keep full confidentiality of the results	L01 – L13
Correction of results and confirmation by participants	L03, L11
Generation of an Excel spreadsheet (ORGDAT.CSV) containing all analytical results	Organiser
Export of all data into PROLAB2000 for statistical evaluation of the results Double check of all data using a PROLAB2000 print-out and the original data report sheets before calculation	Organiser

Several tests of outliers had been carried out before repeatabilities and reproducibilities of the determination of fine grained mass fractions were calculated. According to ISO 5725-2, the following types of outliers were rejected:

Type A: individual within laboratory outlier (e.g. one out of three results deviates significantly),

Type B: between laboratory outlier due to a significant deviation of the laboratory's mean from the overall mean,

Type C: between laboratory outlier due to significant deviation of the within laboratory standard deviation from the overall mean of the within laboratory standard deviations.

After elimination of outliers, the within laboratory means, the within laboratory standard deviations and the coefficients of variation were calculated. A graphical presentation of the analytical results obtained for samples A, B and C is given in Annex 5 together with statistical

parameters of the intercomparison exercise. Outliers are indicated with the above mentioned letters.

3.4. Results

This preliminary report evaluates only the sieving results which are relevant in marine monitoring (mass fraction <20 μm - FS1 and mass fraction < 63 μm - FO1). A detailed final report will be published after the determination of selected contaminants in the separated sediment fractions.

Table 4 summarises the overall statistics of the intercomparison exercise on sieving of marine sediment samples for fractions FS1 and FO1. Repeatabilities between 2 % and 13 % were obtained for the investigated samples A, B and C with worse repeatabilities for the coarse sediment A due to the very low content of fine grained material (see Table 4). Reproducibilities, as a measure for the comparability of the amount of sediment obtained after sieving, are about 25 % for the fine grained sediments B and C and 50 % for fraction FO1 and 75 % for fraction FS1. In intercomparison exercises on analytical determinations, reproducibilities usually are about thrice as high as repeatabilities. Therefore, the high variability of the sieving results obtained in this study can possibly attributed to differences in the sieving procedures applied by the participants.

Table 4: Summary statistics of the Interlaboratory Study „Sieving of Marine Sediments“

Sediment	Sample	No. of Labs	No. of Results	No. of Outliers	Overall Mean [%]	S _r [%]	S _R [%]
A	FS1 (< 20 μm)	12	35	-	1.11	13.75	75.57
B	FS1 (< 20 μm)	12	35	-	16.9	4.65	25.16
C	FS1 (< 20 μm)	12	35	-	22.0	4.54	34.04
A	FO1 (< 63 μm)	11	33	6 (C)	1.43	8.42	50.91
B	FO1 (< 63 μm)	13	38	-	29.8	3.90	25.97
C	FO1 (< 63 μm)	12	34	4 (C)	34.1	2.84	25.53

S_r - relative repeatability; S_R - relative reproducibility

Similar intercomparison exercises were carried out in past to study the influence of sieving on the variability of analytical results [1-3]. As a first evaluation, reproducibilities obtained in previous exercises are comparable to those obtained in this study (between 10 % and 50 %).

5. REFERENCES

- [1] Kramer KJM, Smedes F, Cofino WP, Wegener JWM, Vlachonis G (1999): First Interlaboratory Comparison of the Sieving of Sediments (QUASH Round 2). Report,

QUASH Project Office, FRS Marine Laboratory, PO Box 101, Victoria Road, Aberdeen, AB11 9DB, UK

- [2] Smedes F, Davies IM, Wells D, Allan A, Besada V (2000): Interlaboratory study on sieving and normalisation of geographically different sediments; QUASH round 5. Report, QUASH Project Office, FRS Marine Laboratory, PO Box 101, Victoria Road, Aberdeen, AB11 9DB, UK
- [3] Ackermann F, Bergmann H, Speer W (1983): Zusammenfassung der Ergebnisse der Ringanalyse "Bestimmung von Schwermetallen in Sedimenten". BfG-0162, Bundesanstalt für Gewässerkunde, Koblenz

Annex 1

**List of participants
in alphabetical order**

Address	e-mail Telefon Fax
Dr. Albrecht Bundesamt für Seeschifffahrt und Hydrographie Labor Sülldorf Wüstland 2 22589 HAMBURG Germany	horst.albrecht@bsh.d400.de +49 40 3190 3330 +49 40 3190 5033
Birgit Schubert Bundesanstalt für Gewässerkunde Kaiserin-Augusta-Anlagen 15-17 56068 KOBLENZ Germany	schubert@bafg.de +49 261 1306 5312 +49 261 1306 5363
Dipl.-Ing. R. Hertwig Dipl.-Ing. E. Sawall Chemisches Untersuchungsamt der Stadt Emden Zum Nordkai 16 26725 EMDEN Germany	CHEM.UA@EMDEN.de +49 4921 87 23 50 +49 4921 87 23 56
Dr. Peter Ludwig GBA Gesellschaft für Bioanalytik mbH Flensburger Str. 15 25421 PINNEBERG Germany	p.ludwig@gba-hamburg.de +49 4101 7946 0 +49 4101 7946 26
Dr. Hartmut Schulz Institut für Ostseeforschung Warnemünde Universität Rostock Sektion Marine Geologie Seestraße 15 18119 ROSTOCK Germany	hartmut.schulz@io-warnemuende.de +49 381 5197 392 +49 381 5197 352
Dr. Simon IUQ Institut für Umweltschutz und Qualitätssicherung Dr. Krenzel GmbH Grüner Weg 16a 23936 GREVESMÜHLEN Germany	info@iuq.de +49 3881 78 39 0 +49 3881 78 39 41
Gerda Rürger Christiane Bentke Landesamt für Natur und Umwelt Abteilung II, Labor Saarbrückenstraße 38 24114 KIEL Germany	gruenger@lanu.landsh.de +49 431 6649 112 +49 431 6649 102
Romana Brandsch Limnologisches Institut Dr. Nowak Mayenbrook 1 28870 OTTERSBERG Germany	rb@limnowak.com +49 4205 3175 24 +49 4205 3175 816
Dr. Juris Aigars Marine Monitoring Centre Institute of Aquatic Ecology Latvian University Daugavgrivas 8 1007 RIGA Latvia	juris@monit.lu.lv +371 7614 840 +371 7601 995
Jörg Schütte Niedersächsisches Landesamt für Ökologie An der Scharlake 39	Joerg.Schuette@nloe.niedersachsen.de +49 5121 509 414

Address	e-mail Telefon Fax
31135 HILDESHEIM Germany	+49 5121 509 196
Dr. M. Söllig NORDUM Institut für Umwelt und Analytik GmbH & Co. KG Gewerbepark Am Weidenbruch 18196 KESSIN/ROSTOCK Germany	info@nordum.de +49 38208 637 0 +49 38208 637 28
Dr. Szymon Uscinowicz Polish Geological Institute Branch of Marine Geology st. Koscierska 5 80-328 GDANSK Poland	suscinowicz@pgi.gda.pl +48 58 554 29 09 +48 58 554 29 10
Marion Karge SGS Controll-Co.m.b.H. Institut für Umweltschutzdienstleistungen Ulmenstraße 12a 23966 WISMAR Germany	Marion_Karge@sgs.com +49 3841 26 18 24 +49 3841 25 01 45

Annex 2

Example of a data report sheet

Interlaboratory Study on Sieving of Marine Sediment Samples		
---	--	--

Interlaboratory Study on Sieving of Marine Sediment Samples						
		Interlaboratory Study				Page 2
	Analytical Results Table					
<i>Please use 3 significant figures for the analytical results !</i>						
				Amount of Fraction		
SEDIMENT	Fraction	Code	Units	1	2	3
A	< 20 µm	FS1	%			
A	> 20 µm	FS2	%			
A	< 63 µm	FO1	%			
A	> 63 µm	FO2	%			
B	< 20 µm	FS1	%			
B	> 20 µm	FS2	%			
B	< 63 µm	FO1	%			
B	> 63 µm	FO2	%			
C	< 20 µm	FS1	%			
C	> 20 µm	FS2	%			
C	< 63 µm	FO1	%			
C	> 63 µm	FO2	%			

Annex 3

Original method report sheets

Laboratory Code:		L01			

Sieving < 20 µm						
Sample intake:						
			Sample intake for Replicate			
	SEDIMENT	Fraction	1	2	3	
	A	< 20 µm	20g	20g	20g	
	B	< 20 µm	20g	20g	20g	
	C	< 20 µm	20g	20g	20g	
Equipment:						
Sieve diameter [cm]:						
Sieve material:						
Cleaning of Sieves:						
Procedure:						
		see remarks				
Sieving (wet or dry):						
Sieving support (f.e. balls or sonification):						
Sieving time [min]:						
			settling time: 5 min in 10 cm high water column, density			
			of suspension ca. 0.9%			
Type of water in case of wet sieving:						
			reddestillated			
Volume of water in case of wet sieving [ml]:						
			settling: samples A: 3x820 ml, samples B, C:4x820 ml			
Recirculation of water (yes or no):						
			no	no		
Sieving < 63 µm						
Sample intake:						
			Sample intake for Replicate			
	SEDIMENT	Fraction	1	2	3	
	A	< 63 µm	50g	50g	50g	
	B	< 63 µm	50g	50g	50g	
	C	< 63 µm	50g	50g	50g	
Equipment:						
Sieve diameter [cm]:						
			63 µm			
Sieve material:						
			metal			
Cleaning of Sieves:						
			ultrasonic bath			
Procedure:						
Sieving (wet or dry):						
			wet sieving			
Sieving support (f.e. balls or sonification):						
Sieving time [min]:						
Type of water in case of wet sieving:						
			reddestillated			
Volume of water in case of wet sieving [ml]:						
			samples A16/1 - 670 ml, A16/2 - 670 ml, A16/3 - 640 ml			
			B10/1 - 1215 ml, B10/2 - 1175 ml, B10/3 - 1162 ml			
			C17/1 - 1950 ml, C17/2 - 1455 ml, C17/3 - 1710 ml			
Recirculation of water (yes or no):						
			no			
Remarks:						
fractions <0.02 and >0.02 mm were separated by settling of suspension						
in 10 cm high water column. time of settling: 5 min. After settling rest of						
suspension in 10 cm water column was decanted. Procedure was						
repeated 3 times for sample A and 4 times for samples B and C						
(up to clear water above settled particles)						
overabundance of water in separated fractions was removed by high						
speed centrifugation, and next subsamples were freeze dried						
Preparation of suspension was carried out by 20 min ultrasonic bath						
and next by 15 min mixing						

Laboratory Code:		L02			
Sieving < 20 µm					
Sample intake:					
		Sample intake for Replicate			
	SEDIMENT	Fraction	1	2	3
	A	< 20 µm	0,81 g	0,72 g	0,75 g
	B	< 20 µm	8,54 g	7,96 g	8,11 g
	C	< 20 µm	7,22 g	6,93 g	7,10 g
Equipment:					
Sieve diameter [cm]:		Innendurchmesser : 20 cm			
Sieve material:		rostfreier Edelstahl			
Cleaning of Sieves:		Leitungswasser, dest. Wasser,			
Procedure:					
Sieving (wet or dry):		Naßsiebung			
Sieving support (f.e. balls or sonification):		--			
Sieving time [min]:		ca. 10 - 30 min			
Type of water in case of wet sieving:		dest. Wasser aus Reinstwasseranlage			
Volume of water in case of wet sieving [ml]:		ca. 2000 - 3500 ml			
Recirculation of water (yes or no):		nein			
Sieving < 63 µm					
Sample intake:					
		Sample intake for Replicate			
	SEDIMENT	Fraction	1	2	3
	A	< 63 µm	1,03 g	0,96 g	1,22 g
	B	< 63 µm	16,32 g	17,35 g	18,41 g
	C	< 63 µm	14,01 g	13,82 g	14,20 g
Equipment:					
Sieve diameter [cm]:		Innendurchmesser : 20 cm			
Sieve material:		rostfreier Edelstahl			
Cleaning of Sieves:		Leitungswasser, dest. Wasser,			
Procedure:					
Sieving (wet or dry):		Naßsiebung			
Sieving support (f.e. balls or sonification):		--			
Sieving time [min]:		ca. 10 - 25 min			
Type of water in case of wet sieving:		dest. Wasser aus Reinstwasseranlage			
Volume of water in case of wet sieving [ml]:		ca. 2000 - 3000 ml			
Recirculation of water (yes or no):		nein			
Remarks:		Die Durchführungen der Siebungen erfolgten in Anlehnung an			
		die Methoden der Bundesanstalt für Gewässerkunde.			

Laboratory Code:		L03			
Sieving < 20 µm					
Sample intake:					
		Sample intake for Replicate			
	SEDIMENT	Fraction	1	2	3
	A	< 20 µm	0,3	0,25	0,3
	B	< 20 µm	8,5	8,0	8,5
	C	< 20 µm	11	10	12
Equipment:					
Sieve diameter [cm]:			20		
Sieve material:			stainless steel		
Cleaning of Sieves:			ultrasonic		
Procedure:					
Sieving (wet or dry):			dry		
Sieving support (f.e. balls or sonification):			no		
Sieving time [min]:			30		
Type of water in case of wet sieving:			-		
Volume of water in case of wet sieving [ml]:			-		
Recirculation of water (yes or no):			-		
Sieving < 63 µm					
Sample intake:					
		Sample intake for Replicate (g)			
	SEDIMENT	Fraction	1	2	3
	A	< 63 µm	50	50	50
	B	< 63 µm	50	50	50
	C	< 63 µm	50	50	50
Equipment:					
Sieve diameter [cm]:			20		
Sieve material:			stainless steel		
Cleaning of Sieves:			ultrasonic		
Procedure:					
Sieving (wet or dry):			dry		
Sieving support (f.e. balls or sonification):			no		
Sieving time [min]:			30		
Type of water in case of wet sieving:			-		
Volume of water in case of wet sieving [ml]:			-		
Recirculation of water (yes or no):			-		
Remarks:		Sediment B was not homogeneous. The sediment contains			
		clod of soil.			

Laboratory Code:			L04		
Sieving < 20 µm					
Sample intake:					
			Sample intake for Replicate		
	SEDIMENT	Fraction	1	2	3
	A	< 20 µm	100 g	100 g	100 g
	B	< 20 µm	50 g	25 g	50 g
	C	< 20 µm	25 g	25 g	25 g
Equipment:					
Sieve diameter [cm]:			20		
Sieve material:			Nylon		
Cleaning of Sieves:			washing with rinse; ultrasonic cleaning with demineralized water		
Procedure:					
Sieving (wet or dry):			wet		
Sieving support (f.e. balls or sonification):			sieving on shaking machine with agate balls and careful agitation with plastic spoon		
Sieving time [min]:			90		
Type of water in case of wet sieving:			demineralized water		
Volume of water in case of wet sieving [ml]:			4000-5000		
Recirculation of water (yes or no):			no		
Sieving < 63 µm					
Sample intake:					
			Sample intake for Replicate		
	SEDIMENT	Fraction	1	2	3
	A	< 63 µm	100 g	100 g	100 g
	B	< 63 µm	100 g	50 g	50 g
	C	< 63 µm	50 g	25 g	25 g
Equipment:					
Sieve diameter [cm]:			20		
Sieve material:			Nylon		
Cleaning of Sieves:			washing with rinse; ultrasonic cleaning with demineralized water		
Procedure:					
Sieving (wet or dry):			wet		
Sieving support (f.e. balls or sonification):			sieving on shaking machine with agate balls and careful agitation with plastic spoon		
Sieving time [min]:			60		
Type of water in case of wet sieving:			demineralized water		
Volume of water in case of wet sieving [ml]:			2000-3000		
Recirculation of water (yes or no):			no		
Remarks:					
			<p>During centrifugation at 4000 rpm very fine underflow did not settled completely. For that reason the different sieving fractions were not centrifuged.</p> <p>The separation from the water was carried out as follows: The oversize was rinsed from the respective sieve using demineralized water. Oversize and underflow were filtered by using membrane filter (pore size 0,45 µm) The filtercake was rinsed from the membrane filter using a small amount of demineralized water and freeze-dried subsequently. During vacuum-freeze-drying a slight dusting of very fine particles was observed (slight sample loss). The difference between the parts of oversize and underflow is mostly the soluble salt content of the sediment. The determination of the salt content was carried out according to VDLUFA, Vol. I (1999), cap. 10.1.1 (determination of electrical conductivity and normalization to KCl). The following contents were determined: sediment A/North Sea: 0</p>		
Remarks:					
			<p>Die einzelnen Siebfraktionen wurden nicht zentrifugiert, da sich nach Zentrifugation bei 4000 U/min der Feinanteil nicht vollständig absetzte.</p> <p>Es wurde wie folgt verfahren: Die Siebrückstände wurden mittels deionisiertem Wasser vom jeweiligen Sieb gespült. Siebrückstände und Siebdurchgänge wurden über einen Membranfilter, Porenweite 0,45 µm, filtriert. Der Filterkuchen wurde mit wenig Wasser vom Filter gespült und gefriergetrocknet. Während der Gefrier Trocknung konnte ein Zerstäuben des Feinanteils festgestellt werden (geringer Probenverlust). Die Differenz zwischen dem gravimetrisch ermittelten Grob- und Feinanteil ist größtenteils auf den löslichen Salzgehalt des</p>		

		Sedimentes zurückzuführen. Die Bestimmung des Salzgehaltes erfolgte nach VDLUFA, Bd. I (1999), Kap. 10.1.1. (KCl-Normierung der elektrischen Leitfähigkeit). Folgende Salzgehalte wurden ermittelt: Sediment A/Nordsee: 0,9 %, Sediment B/Elbe: 0,1 %, Sediment C/			
Laboratory Code:		L05			
Sieving < 20 µm					
Sample intake:					
		Sample intake for Replicate			
	SEDIMENT	Fraction	1	2	3
	A	< 20 µm	400,00g	21,93g	75,00g
	B	< 20 µm	50,00g	50,00g	50,00g
	C	< 20 µm	50,00g	50,00g	50,00g
Equipment:					
Sieve diameter [cm]:		Innendurchmesser: 72mm			
Sieve material:		Nylongewebe auf Plexiglasrohr			
Cleaning of Sieves:		Ultraschallstab und Nachreinigung mit VE - Wasser			
Procedure:					
Sieving (wet or dry):		Nasssiebung			
Sieving support (f.e. balls or sonification):		Ultraschallsiebung ohne Hilfsmittel			
Sieving time [min]:		Individuell bis zum klaren Ablauf der Fraktion			
Type of water in case of wet sieving:		VE - Wasser			
Volume of water in case of wet sieving [ml]:		ca. 600 - 1000ml			
Recirculation of water (yes or no):		nein			
Sieving < 63 µm					
Sample intake:					
		Sample intake for Replicate			
	SEDIMENT	Fraction	1	2	3
	A	< 63 µm	10,00g/10,00g	400,00g	75,00g
	B	< 63 µm	50,00g	50,00g	50,00g
	C	< 63 µm	50,00g	50,00g	50,00g
Equipment:					
Sieve diameter [cm]:		Innendurchmesser: 72mm			
Sieve material:		Nylongewebe auf Plexiglasrohr			
Cleaning of Sieves:		Ultraschallstab und Nachreinigung mit VE - Wasser			
Procedure:					
Sieving (wet or dry):		Nasssiebung			
Sieving support (f.e. balls or sonification):		Ultraschallsiebung ohne Hilfsmittel			
Sieving time [min]:		Individuell bis zum klaren Ablauf der Fraktion			
Type of water in case of wet sieving:		VE - Wasser			
Volume of water in case of wet sieving [ml]:		ca. 600 - 1000ml			
Recirculation of water (yes or no):		nein			
Remarks:					
		Naßsiebung pro Fraktion mit ca 1 Liter Wasser			
		Anschließend zentrifugiert (4000 U / Min) ca. 10 Minuten			
		Überstehende Flüssigkeit leicht bräunlich bei B und C,			
		bei A Färbung schwach beige.			
		Probe A (alle Fraktionen) bei 55°C getrocknet,			
		die Proben B und C (alle Fraktionen) wurden gefriergetrocknet.			
		Die Fraktionen < 63 µm bzw. <20 µm wurden mittels Kugelmörser			
		zerkleinert und danach abgefüllt.			

Laboratory Code:		L06			
------------------	--	------------	--	--	--

Sieving < 20 µm						
Sample intake:						
			Sample intake for Replicate			
	SEDIMENT	Fraction	1	2	3	
	A	< 20 µm	100g	100g	200g	
	B	< 20 µm	25g	25g	50g	
	C	< 20 µm	50g	50g	100g	
Equipment:						
Sieve diameter [cm]:		7,4 cm				
Sieve material:		20 microns plastic mesh (size checked by SEM), acryl cylinder				
Cleaning of Sieves:		ultrasonically				
Procedure:						
Sieving (wet or dry):			wet			
Sieving support (f.e. balls or sonification):			sonification			
Sieving time [min]:			approx. 10min			
Type of water in case of wet sieving:			MILLI-PORE MILLI-RO35TS			
Volume of water in case of wet sieving [ml]:			approx. 2000ml			
Recirculation of water (yes or no):			no, see method			
Sieving < 63 µm						
Sample intake:						
			Sample intake for Replicate			
	SEDIMENT	Fraction	1	2	3	
	A	< 63 µm	100g	100g	100g	
	B	< 63 µm	50g	50g	100g	
	C	< 63 µm	50g	50g	100g	
Equipment:						
Sieve diameter [cm]:		7,4 cm				
Sieve material:		60 microns mesh, acryl cylinder				
Cleaning of Sieves:		ultrasonically				
Procedure:						
Sieving (wet or dry):			wet			
Sieving support (f.e. balls or sonification):			sonification			
Sieving time [min]:			approx. 10min			
Type of water in case of wet sieving:			MILLI-PORE MILLI-RO35TS			
Volume of water in case of wet sieving [ml]:			approx. 2000ml			
Recirculation of water (yes or no):			no, see method			
Remarks:						
		Short description of the mehod applied:				
		All instrumets were cleaned with MILLI-PORE water. Parcels of about				
		5-20 g of sediment were put into the sieve and bathed in a 2.5 l beaker				
		that was installed in an ultrasonic bath and was filled with some water.				
		Thus, the ultrasonic bath effected the pr				

Laboratory Code:	L07			
------------------	------------	--	--	--

Sieving < 20 µm						
Sample intake:						
			Sample intake for Replicate			
	SEDIMENT	Fraction	1	2	3	
	A	< 20 µm	20	20	20	
	B	< 20 µm	10	10	10	
	C	< 20 µm	10	10	10	
Equipment:						
Sieve diameter [cm]:			8			
Sieve material:			Nylon			
Cleaning of Sieves:			Extran (alkaline)/deion. water			
Procedure:						
Sieving (wet or dry):			wet			
Sieving support (f.e. balls or sonification):			sonification			
Sieving time [min]:			5-10 min			
Type of water in case of wet sieving:			deion. water			
Volume of water in case of wet sieving [ml]:			1000 / 10 g dry sediment			
Recirculation of water (yes or no):			no			
Sieving < 63 µm						
Sample intake:						
			Sample intake for Replicate			
	SEDIMENT	Fraction	1	2	3	
	A	< 63 µm	20	20	20	
	B	< 63 µm	10	10	10	
	C	< 63 µm	10	10	10	
Equipment:						
Sieve diameter [cm]:			8			
Sieve material:			Nylon			
Cleaning of Sieves:			Extran (alkaline)/deion. Water			
Procedure:						
Sieving (wet or dry):			wet			
Sieving support (f.e. balls or sonification):			sonification			
Sieving time [min]:			5-10 min			
Type of water in case of wet sieving:			deion. water			
Volume of water in case of wet sieving [ml]:			1000 /10 g dry sediment			
Recirculation of water (yes or no):			no			
Remarks:						
		10 µM calcium chloride was added for the fraction <20µm				
		for a better sedimentation.				
		The fractions were freeze-dried, but not pulverized.				

Sieving < 20 µm						
Sample intake:						
			Sample intake for Replicate			
	SEDIMENT	Fraction	1	2	3	
	A	< 20 µm	52,64	56,93	44,53	
	B	< 20 µm	48,49	28,46	29,20	
	C	< 20 µm	45,60	32,23	25,50	
Equipment:						
Sieve diameter [cm]:			20			
Sieve material:			Stahl			
Cleaning of Sieves:			Wasser/Bürste			
Procedure:						
Sieving (wet or dry):			nass und trocken			
Sieving support (f.e. balls or sonification):			Bälle (nass)			
Sieving time [min]:			90-120 (trocken), 10 (nass)			
Type of water in case of wet sieving:			demineralisiert			
Volume of water in case of wet sieving [ml]:			1500			
Recirculation of water (yes or no):			nein			
Sieving < 63 µm						
Sample intake:						
			Sample intake for Replicate			
	SEDIMENT	Fraction	1	2	3	
	A	< 63 µm	52,38	50,00	48,36	
	B	< 63 µm	58,19	59,21	50,19	
	C	< 63 µm	55,01	55,30	45,86	
Equipment:						
Sieve diameter [cm]:			20			
Sieve material:			Stahl			
Cleaning of Sieves:			Wasser/Bürste			
Procedure:						
Sieving (wet or dry):			nass und trocken			
Sieving support (f.e. balls or sonification):			Bälle (nass)			
Sieving time [min]:			90-120 (trocken), 10 (nass)			
Type of water in case of wet sieving:			demineralisiert			
Volume of water in case of wet sieving [ml]:			1500			
Recirculation of water (yes or no):			nein			
Remarks:						
		Siebung 1 + 2 trocken, Siebung 3 nass				

Laboratory Code:	L09			
------------------	------------	--	--	--

Sieving < 20 µm						
Sample intake:						
			Sample intake for Replicate			
	SEDIMENT	Fraction	1	2	3	
	A	< 20 µm				
	B	< 20 µm				
	C	< 20 µm				
Equipment:						
Sieve diameter [cm]:						
Sieve material:						
Cleaning of Sieves:						
Procedure:						
Sieving (wet or dry):						
Sieving support (f.e. balls or sonification):						
Sieving time [min]:						
Type of water in case of wet sieving:						
Volume of water in case of wet sieving [ml]:						
Recirculation of water (yes or no):						
Sieving < 63 µm						
Sample intake:						
			Sample intake for Replicate			
	SEDIMENT	Fraction	1	2	3	
	A	< 63 µm	123,87	13,04	89,86	
	B	< 63 µm	88,15	83,89	89,66	
	C	< 63 µm	60,46	69,08	130,08	
Equipment:						
Sieve diameter [cm]: 20 cm						
Sieve material: Nylon						
Cleaning of Sieves: MQ water						
Procedure:						
Sieving (wet or dry): dry						
Sieving support (f.e. balls or sonification):						
Sieving time [min]: 5						
Type of water in case of wet sieving:						
Volume of water in case of wet sieving [ml]:						
Recirculation of water (yes or no):						
Remarks:						
Sieving was continued after three replicates until all material						
from one bottle was sieved						

Laboratory Code:

L10

Sieving < 20 µm						
Sample intake:						
			Sample intake for Replicate / g			
	SEDIMENT	Fraction	1	2	3	
	A	< 20 µm	30,19	29,97	30,18	
	B	< 20 µm	35,15	34,47	40,31	
	C	< 20 µm	11,02	11,88	11,53	
Equipment:						
Sieve diameter [cm]:			7,4			
Sieve material:			Monyl (Polyamid, farblos), Röhre: Plexiglas (farblos, extrudiert), Kleber: Acrifix 192			
Cleaning of Sieves:			weiche Bürste, Osmose-, dann Reinstwasser, US-Bad			
Procedure:						
Sieving (wet or dry):			naß			
Sieving support (f.e. balls or sonification):			Ultraschall, 2 Achatkugeln			
Sieving time [min]:			je Siebgang 5 min, 6 – 8 Siebgänge			
Type of water in case of wet sieving:			Reinstwasser, c < 0,060 µS/cm			
Volume of water in case of wet sieving [ml]:			60 – 70			
Recirculation of water (yes or no):			ja			
Sieving < 63 µm						
Sample intake:						
			Sample intake for Replicate			
	SEDIMENT	Fraction	1	2	3	
	A	< 63 µm	30,27	29,99	30,66	
	B	< 63 µm	35,31	34,77	34,79	
	C	< 63 µm	12,29	11,75	12,60	
Equipment:						
Sieve diameter [cm]:			7,4			
Sieve material:			Monyl (Polyamid, farblos), Röhre: Plexiglas (farblos, extrudiert), Kleber: Acrifix 192			
Cleaning of Sieves:			weiche Bürste, Osmose-, dann Reinstwasser, US-Bad			
Procedure:						
Sieving (wet or dry):			naß			
Sieving support (f.e. balls or sonification):			Ultraschall, 2 Achatkugeln			
Sieving time [min]:			je Siebgang 5 min, 6 – 8 Siebgänge			
Type of water in case of wet sieving:			Reinstwasser, c < 0,060 µS/cm			
Volume of water in case of wet sieving [ml]:			60 – 70			
Recirculation of water (yes or no):			ja			
Remarks:						
Sonst untersuchen wir die Metall-Konzentrationen in den < Fraktionen und der Gesamtfraktion.						
Unser Siebverfahren ist demgemäß anders als beim Ringversuch.						
Verfahren sonst:						
- Vorsiebe 2 mm, 0,5 mm, 0,2 mm (zum Abtrennen von Kies, Blättern, Muscheln, Holz usw.)						
- Fraktion < 200 µm auf Sieb 63 µm						
- Durchgang davon auf Sieb 20 µm						
- letzter Schritt nur, wenn Anteil < 20 µm gefragt ist oder die Metalle in dieser Fraktion bestimmt werden sollen						
- ggf. werden org. Bestandteile im „Dekantierverfahren“ abgetrennt						

Laboratory Code:		L11			
Sieving < 20 µm					
Sample intake:					
		Sample intake for Replicate			
	SEDIMENT	Fraction	1	2	3
	A	< 20 µm	148	75,7	70,8
	B	< 20 µm	86,3	69,9	78
	C	< 20 µm	60,6	45	44,1
Equipment:					
Sieve diameter [cm]:				7	
Sieve material:				Nylon	
Cleaning of Sieves:				ultrasonic bath, Milli-Q water	
Procedure:					
Sieving (wet or dry):				wet	
Sieving support (f.e. balls or sonification):				both	
Sieving time [min]:				5, repeatedly	
Type of water in case of wet sieving:				Milli-Q	
Volume of water in case of wet sieving [ml]:				up to 3000	
Recirculation of water (yes or no):				no	
Sieving < 63 µm					
Sample intake:					
		Sample intake for Replicate			
	SEDIMENT	Fraction	1	2	3
	A	< 63 µm	77,7	67,5	70,7
	B	< 63 µm	65,1	78,8	70,5
	C	< 63 µm	55,2	46,7	41,1
Equipment:					
Sieve diameter [cm]:				7	
Sieve material:				Nylon	
Cleaning of Sieves:				ultrasonic bath, Milli-Q water	
Procedure:					
Sieving (wet or dry):				wet	
Sieving support (f.e. balls or sonification):				both	
Sieving time [min]:				5, repeatedly	
Type of water in case of wet sieving:				Milli-Q	
Volume of water in case of wet sieving [ml]:				up to 3000	
Recirculation of water (yes or no):				no	
Remarks:					
				Da gefriergetrocknete Meeressedimente Seesalz enthalten	
				und dies bei der Naßsiebung verlorenggeht, arbeiten wir nicht	
				mit Einwaagen, sondern nur mit Auswaagen. Die oben	
				angegebenen „intakes“ sind die Summen der ausgewogenen	
				Fraktionen.	

Laboratory Code:		L12			
Sieving < 20 µm					
Sample intake:					
			Sample intake for Replicate		
	SEDIMENT	Fraction	1	zur %Kornvert.	Entfällt
	A	< 20 µm	372g	62,4	
	B	< 20 µm	87,7g	10,1	
	C	< 20 µm	66,2	10,9	
Equipment:					
Sieve diameter [cm]:		200mm		100mm	
Sieve material:		Siebfolie		Metallsieb	
Cleaning of Sieves:		Wasser mit 2% Mucosol im Ultraschallbad			
Procedure:					
Sieving (wet or dry):		naß		naß	
Sieving support (f.e. balls or sonification):					
Sieving time [min]:		Bis der Ablauf Klar ist mindestens 15 Min.			
Type of water in case of wet sieving:		VE			
Volume of water in case of wet sieving [ml]:		1,5 – 2 Lieter			
Recirculation of water (yes or no):		ja			
Sieving < 63 µm					
Sample intake:					
			Sample intake for Replicate		
	SEDIMENT	Fraction	1	zur %Kornvert.	Entfällt
	A	< 63 µm	486,7g	63	
	B	< 63 µm	87,7g	10,1g	
	C	< 63 µm	66,2g	10,9g	
Equipment:					
Sieve diameter [cm]:		200mm		100mm	
Sieve material:		Metallsieb		Metallsieb	
Cleaning of Sieves:		Wasser mit 2% Mucosol im Ultraschallbad			
Procedure:					
Sieving (wet or dry):		naß		naß	
Sieving support (f.e. balls or sonification):					
Sieving time [min]:		Bis der Ablauf Klar ist mindestens 15 Min.			
Type of water in case of wet sieving:		VE			
Volume of water in case of wet sieving [ml]:		1,5 – 2 Lieter			
Recirculation of water (yes or no):		ja			
Remarks:					
Aus den Proben wurden mittels Probenteiler repräsentative Teil-					
proben hergestellt, die für die einzelnen Arbeitsgänge verwendet wurden.					
1.) Zur Ermittlung der Kornverteilung wurde eine Naßsiebung über					
100 mm- Edelstahlsiebe durchgeführt: Einwaage siehe unter					
% Kornverteilung					
2.) Zur Gewinnung der < 63 µm – u. > 63 µm – Fraktion					
für die Rücksendung erfolgte Naßsiebung größerer					
Probemengen über ein 200 mm Edelstahlsieb.					
3.) Zur Gewinnung der < 20 µm – u. > 20 µm – Fraktion					
für die Rücksendung erfolgte Naßsiebung größerer					
Probemengen über einen speziellen Siebaufsatz mit					
auswechselbarer Siebfolie.					

Laboratory Code:	L13				
Sieving < 20 µm					
Sample intake:					
	Sample intake for Replicate				
	SEDIMENT	Fraction	1	2	3
	A	< 20 µm	57	59	57
	B	< 20 µm	48	48	37
	C	< 20 µm	21	20	20
Equipment:					
Sieve diameter [cm]:			8 cm		
Sieve material:			Monodur-Polyamid Normal		
Cleaning of Sieves:			washing with deionised water		
Procedure:					
Sieving (wet or dry):			wet sieving		
Sieving support (f.e. balls or sonification):			addition of 3 agate balls and ultrasonic treatment		
Sieving time [min]:			cf. Remarks		
Type of water in case of wet sieving:			deionised water		
Volume of water in case of wet sieving [ml]:			ca. 500 - 600 ml		
Recirculation of water (yes or no):			no		
Sieving < 63 µm					
Sample intake:					
	Sample intake for Replicate				
	SEDIMENT	Fraction	1	2	3
	A	< 63 µm	150	250	200
	B	< 63 µm	100	75	75
	C	< 63 µm	60	60	60
Equipment:					
Sieve diameter [cm]:			8 cm		
Sieve material:			Monodur-Polyamid Normal		
Cleaning of Sieves:			washing with deionised water		
Procedure:					
Sieving (wet or dry):			wet sieving		
Sieving support (f.e. balls or sonification):			addition of 3 agate balls and ultrasonification		
Sieving time [min]:			cf. Remarks		
Type of water in case of wet sieving:			deionised water		
Volume of water in case of wet sieving [ml]:			ca. 2000 ml, depending on sample intake/type of sample		
Recirculation of water (yes or no):			partially, i.e. water from the first small batches were reused for subsequent batches		
Remarks:					
Samples were subjected to sieving through a 200 µm sieve prior to sieving through the 63 µm sieve. In order to avoid a clogging of sieve foils, sieving was carried out in several small batches. All batches were subjected to ultrasonification several times (up to 40 times) for about 3 - 5 min each time until the water phase passing the sieve remained clear.					
After centrifugation, water was reused for subsequent batches.					
The fines (< 20 µm and < 63 µm) were separated from the water phase by centrifugation. All coarse fractions of a sample were combined and homogenised in a ball mill to give FS2 and FO2.					
The fraction 20 - 63 µm of sample B contained considerable amounts of light, dark organic material that did not pass the sieve 20 µm even after repeated ultrasonic treatment.					

Annex 4

Original data

A	< 63 µm	FO1	%	2,27	2,39	2,52		L01
A	> 63 µm	FO2	%	97,66	97,61	97,52		L01
A	< 20 µm	FS1	%	0,15	0,13	0,12		L01
A	> 20 µm	FS2	%	98,55	98,53	98,56		L01
B	< 63 µm	FO1	%	34,06	35,45	33,65		L01
B	> 63 µm	FO2	%	64,86	64,21	65,88		L01
B	< 20 µm	FS1	%	17,4	17,35	17,35		L01
B	> 20 µm	FS2	%	77,79	79,56	79,78		L01
C	< 63 µm	FO1	%	39,89	38,26	41,42		L01
C	> 63 µm	FO2	%	56,98	58,08	55,73		L01
C	< 20 µm	FS1	%	23,76	24,25	22,81		L01
C	> 20 µm	FS2	%	72,06	71,15	72,57		L01
A	< 63 µm	FO1	%	1,03	1,2	1,19		L02
A	> 63 µm	FO2	%	97,7	98,2	97,76		L02
A	< 20 µm	FS1	%	0,81	0,89	0,74		L02
A	> 20 µm	FS2	%	97,9	98,97	98,81		L02
B	< 63 µm	FO1	%	32,74	32,41	32,01		L02
B	> 63 µm	FO2	%	65,4	66,7	68,15		L02
B	< 20 µm	FS1	%	17,17	15,9	15,64		L02
B	> 20 µm	FS2	%	81,02	84,32	85,07		L02
C	< 63 µm	FO1	%	35,27	33,79	33,58		L02
C	> 63 µm	FO2	%	62,7	64,3	65,03		L02
C	< 20 µm	FS1	%	17,87	17,45	17,88		L02
C	> 20 µm	FS2	%	80,19	82,08	79,07		L02
A	< 63 µm	FO1	%	0,561	0,852	0,658		L03
A	> 63 µm	FO2	%	99,4	99,1	99,3		L03
A	< 20 µm	FS1	%	0,315	0,292	0,262		L03
A	> 20 µm	FS2	%	99,685	99,708	99,738		L03
B	< 63 µm	FO1	%	16,9	16,6	15		L03
B	> 63 µm	FO2	%	83,1	83,4	85		L03
B	< 20 µm	FS1	%	10,8	9,52	8,46		L03
B	> 20 µm	FS2	%	89,2	90,48	91,54		L03
C	< 63 µm	FO1	%	22,8	22	22,8		L03
C	> 63 µm	FO2	%	77,2	78	77,2		L03
C	< 20 µm	FS1	%	17,4	14,5	14		L03
C	> 20 µm	FS2	%	82,6	85,5	86		L03
A	< 63 µm	FO1	%	1,3	1,41	1,62		L04
A	> 63 µm	FO2	%	97,64	97,57	97,33		L04
A	< 20 µm	FS1	%	0,93	1,08	1,01		L04
A	> 20 µm	FS2	%	98,1	97,89	97,95		L04
B	< 63 µm	FO1	%	36,29	37,06	37,92		L04
B	> 63 µm	FO2	%	62,76	62,54	61,7		L04
B	< 20 µm	FS1	%	18,46	18,56	19,14		L04
B	> 20 µm	FS2	%	81,02	80,88	80,24		L04
C	< 63 µm	FO1	%	41,68	42,6	41,4		L04
C	> 63 µm	FO2	%	55,82	54,84	55,84		L04
C	< 20 µm	FS1	%	28,8	29,36	29,12		L04
C	> 20 µm	FS2	%	68,32	68,44	68,24		L04
A	< 63 µm	FO1	%	1	1	1,11	1,3	L05
A	> 63 µm	FO2	%	95,9	98,27	97,9	96,1	L05
A	< 20 µm	FS1	%	0,74	1	1,05		L05

A	> 20 µm	FS2	%	98,1	98,9	97,8		L05
B	< 63 µm	FO1	%	26,7	25,5	24,2		L05
B	> 63 µm	FO2	%	71,9	73,3	74,8		L05
B	< 20 µm	FS1	%	13	11,8	10,1		L05
B	> 20 µm	FS2	%	86	87,2	88,9		L05
C	< 63 µm	FO1	%	27,4	26,2	25,3		L05
C	> 63 µm	FO2	%	70,7	71,8	73,2		L05
C	< 20 µm	FS1	%	16,1	15,3	14,4		L05
C	> 20 µm	FS2	%	81,6	82,1	80,6		L05
A	< 63 µm	FO1	%	0,88	0,96	0,74	0,86	L06
A	> 63 µm	FO2	%	99,12	99,04	99,26	99,14	L06
A	< 20 µm	FS1	%	0,36	0,84	0,12	0,44	L06
A	> 20 µm	FS2	%	99,64	99,16	99,88	99,56	L06
B	< 63 µm	FO1	%	29,02	28,56	26,18	27,92	L06
B	> 63 µm	FO2	%	70,98	71,44	73,82	72,07	L06
B	< 20 µm	FS1	%	12	12,97	12,77	12,58	L06
B	> 20 µm	FS2	%	88	87,03	87,23	87,42	L06
C	< 63 µm	FO1	%	20,45	27,83	18,98	22,42	L06
C	> 63 µm	FO2	%	79,55	72,17	81,02	77,58	L06
C	< 20 µm	FS1	%	12,89	12,14	11,51	12,18	L06
C	> 20 µm	FS2	%	87,11	87,86	88,48	87,82	L06
A	< 63 µm	FO1	%	2,5	3,3	3,5		L07
A	> 63 µm	FO2	%	97,5	96,7	96,5		L07
A	< 20 µm	FS1	%	1,9	2,4	2,3		L07
A	> 20 µm	FS2	%	98,1	97,6	97,7		L07
B	< 63 µm	FO1	%	36,7	35,3	36,2		L07
B	> 63 µm	FO2	%	63,3	64,7	63,8		L07
B	< 20 µm	FS1	%	22	20,4	20,4		L07
B	> 20 µm	FS2	%	78	79,6	79,6		L07
C	< 63 µm	FO1	%	41,8	43,6	40,9		L07
C	> 63 µm	FO2	%	58,2	56,4	59,1		L07
C	< 20 µm	FS1	%	26,7	26,8	26		L07
C	> 20 µm	FS2	%	73,3	73,2	74		L07
A	< 63 µm	FO1	%	1,39	1,68	1,64		L08
A	> 63 µm	FO2	%	98,6	98,3	98,4		L08
A	< 20 µm	FS1	%	0,38	0,316	0,34		L08
A	> 20 µm	FS2	%	99,6	99,7	99,7		L08
B	< 63 µm	FO1	%	29,2	32,6	33,6		L08
B	> 63 µm	FO2	%	70,9	67,4	66,4		L08
B	< 20 µm	FS1	%	16,5	16,1	16,4		L08
B	> 20 µm	FS2	%	83,5	83,9	83,6		L08
C	< 63 µm	FO1	%	30,4	29,6	28,9		L08
C	> 63 µm	FO2	%	69,6	70,4	71,1		L08
C	< 20 µm	FS1	%	14,2	14,5	14		L08
C	> 20 µm	FS2	%	85,8	85,5	86		L08
A	< 63 µm	FO1	%	0,55	0,46	0,6		L09
A	> 63 µm	FO2	%	99,45	99,54	99,6		L09
B	< 63 µm	FO1	%	13	12,96	13,28		L09
B	> 63 µm	FO2	%	87	87,04	86,72		L09
C	< 63 µm	FO1	%	18,54	18,16	17,26		L09
C	> 63 µm	FO2	%	81,46	81,84	82,74		L09
A	< 63 µm	FO1	%	2,81	2,77	2,78		L10

A	> 63 µm	FO2	%	97,19	97,23	97,22		L10
A	< 20 µm	FS1	%	2,32	2,3	2,42		L10
A	> 20 µm	FS2	%	97,68	97,7	97,58		L10
B	< 63 µm	FO1	%	38,26	37,36	35,3		L10
B	> 63 µm	FO2	%	61,74	62,64	64,7		L10
B	< 20 µm	FS1	%	23,87	23,18	22,9		L10
B	> 20 µm	FS2	%	76,13	76,82	77,1		L10
C	< 63 µm	FO1	%	43,69	45,62	43,1		L10
C	> 63 µm	FO2	%	56,31	54,38	56,9		L10
C	< 20 µm	FS1	%	33,39	32,07	30,27		L10
C	> 20 µm	FS2	%	66,61	67,93	69,73		L10
A	< 63 µm	FO1	%	1,8	2,48	1,7		L11
A	< 20 µm	FS1	%	1,35	1,51	1,33		L11
B	< 63 µm	FO1	%	33,8	32,6	33,1		L11
B	< 20 µm	FS1	%	21,3	20,2	19,6		L11
C	< 63 µm	FO1	%	36,8	38,1	38,2		L11
C	< 20 µm	FS1	%	29,4	26,4	27,4		L11
A	< 63 µm	FO1	%	2,3				L12
A	> 63 µm	FO2	%	97,7				L12
A	< 20 µm	FS1	%	1,9				L12
A	> 20 µm	FS2	%	98,1				L12
B	< 63 µm	FO1	%	31,4				L12
B	> 63 µm	FO2	%	68,6				L12
B	< 20 µm	FS1	%	18,1				L12
B	> 20 µm	FS2	%	81,9				L12
C	< 63 µm	FO1	%	32,2				L12
C	> 63 µm	FO2	%	67,8				L12
C	< 20 µm	FS1	%	24,1				L12
C	> 20 µm	FS2	%	75,9				L12
A	< 63 µm	FO1	%	1,9	1,7	1,7		L13
A	> 63 µm	FO2	%	96,9	96,9	97,1		L13
A	< 20 µm	FS1	%	2,2	2,3	2,4		L13
A	> 20 µm	FS2	%	97,8	97,7	97,6		L13
B	< 63 µm	FO1	%	32,8	34,3	31,7		L13
B	> 63 µm	FO2	%	65,7	63	66		L13
B	< 20 µm	FS1	%	19,7	18,8	20,4		L13
B	> 20 µm	FS2	%	80,3	81,2	79,6		L13
C	< 63 µm	FO1	%	39,7	40,1	39,8		L13
C	> 63 µm	FO2	%	55,6	54,6	54,3		L13
C	< 20 µm	FS1	%	31,5	32,5	30,3		L13
C	> 20 µm	FS2	%	68,5	67,5	69,7		L13

Annex 5

Statistical evaluation of results

Laboratory results

Ring test: Sediment Sieving
 Sample: North Sea Sediment
 Analyte: Fraction < 20 µm
 Number of laboratories: 12
 Number of measurements: 35

Mean: 1.113 %
 Rel. repeatability s.d (sr,rel):13.75%
 Rel. reproducibility s.d.: 75.57%
 Number of outlier measurements: 0

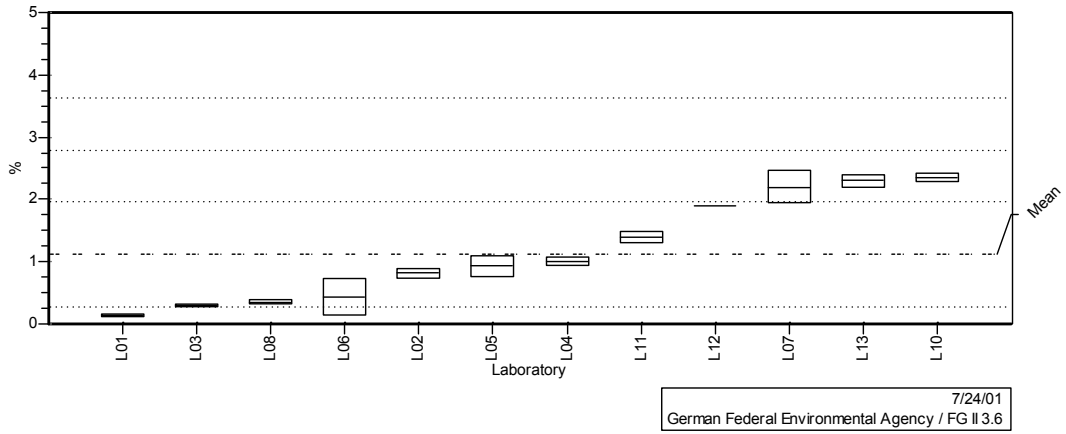

Laboratory results

Ring test: Sediment Sieving
 Sample: North Sea Sediment
 Analyte: Fraction < 63 µm
 Number of laboratories: 11
 Number of measurements: 33

Mean: 1.428 %
 Rel. repeatability s.d (sr,rel):8.42%
 Rel. reproducibility s.d.: 50.91%
 Number of outlier measurements: 6

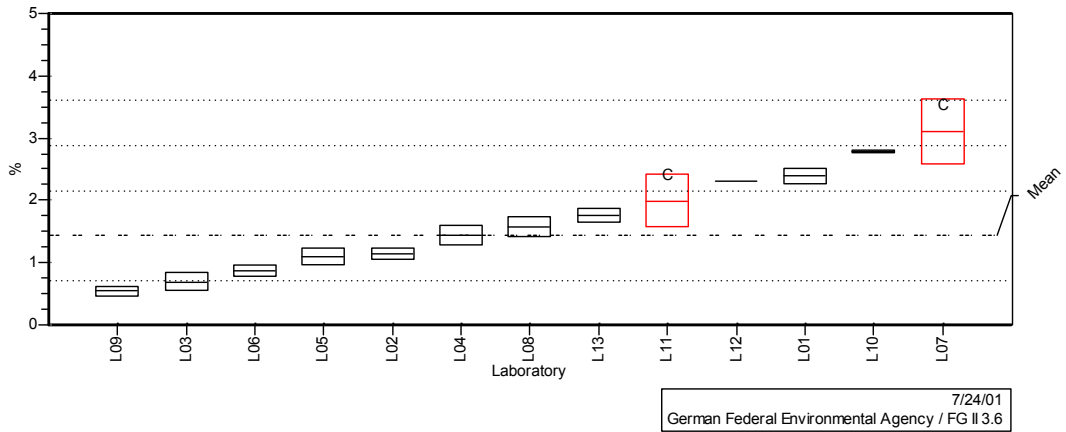

Laboratory results

Ring test: Sediment Sieving
 Sample: Elbe Estuary Sediment
 Analyte: Fraction < 20 µm
 Number of laboratories: 12
 Number of measurements: 35

Mean: 16.881 %
 Rel. repeatability s.d (sr,rel): 4.65%
 Rel. reproducibility s.d.: 25.16%
 Number of outlier measurements: 0

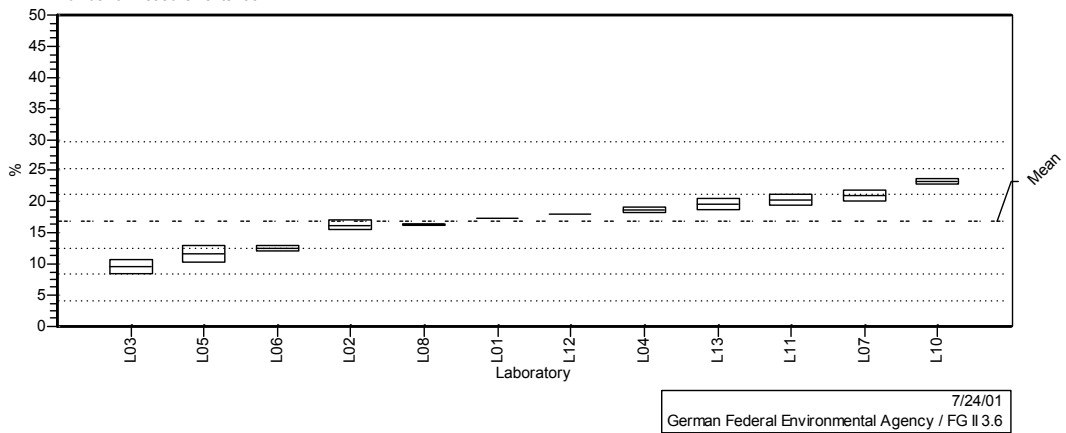

Laboratory results

Ring test: Sediment Sieving
 Sample: Elbe Estuary Sediment
 Analyte: Fraction < 63 µm
 Number of laboratories: 13
 Number of measurements: 38

Mean: 29.780 %
 Rel. repeatability s.d (sr,rel): 3.90%
 Rel. reproducibility s.d.: 25.97%
 Number of outlier measurements: 0

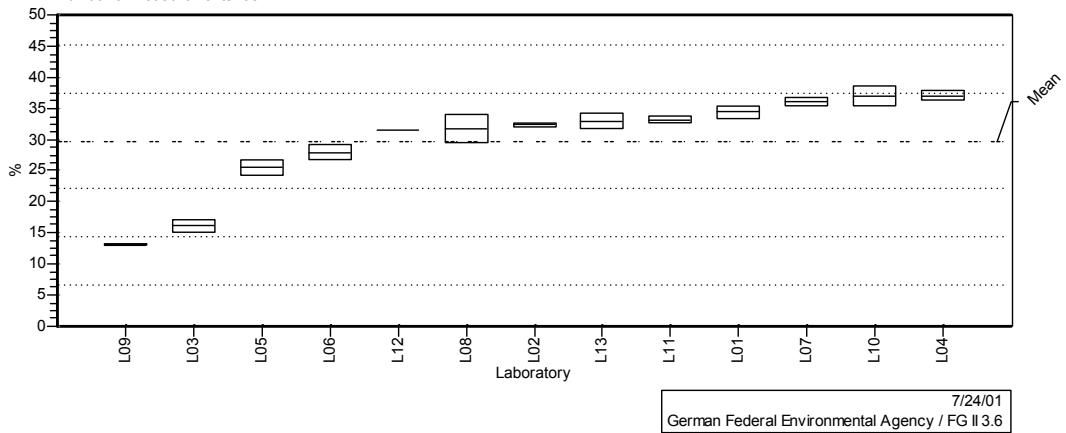

Laboratory results

Ring test: Sediment Sieving
 Sample: Baltic Sea Sediment
 Analyte: Fraction < 20 µm
 Number of laboratories: 12
 Number of measurements: 35

Mean: 22.036 %
 Rel. repeatability s.d (sr,rel): 4.54%
 Rel. reproducibility s.d.: 34.04%
 Number of outlier measurements: 0

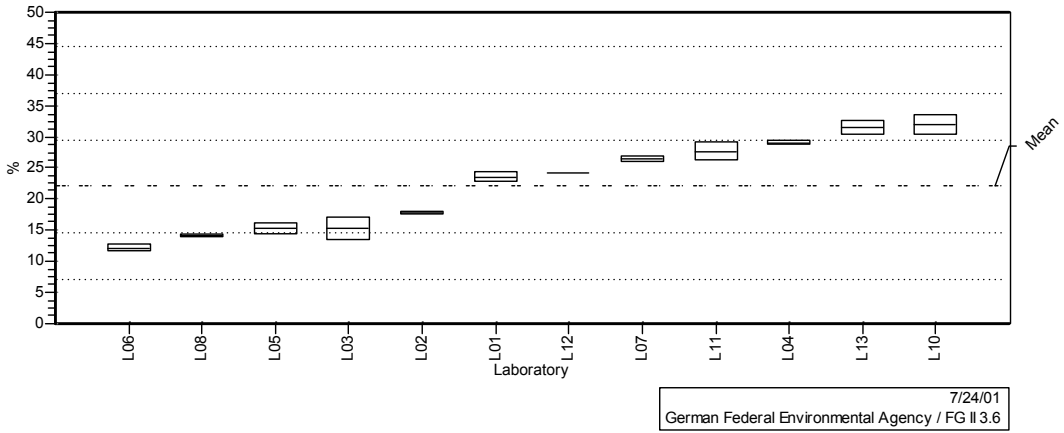

Laboratory results

Ring test: Sediment Sieving
 Sample: Baltic Sea Sediment
 Analyte: Fraction < 63 µm
 Number of laboratories: 12
 Number of measurements: 34

Mean: 34.143 %
 Rel. repeatability s.d (sr,rel): 2.84%
 Rel. reproducibility s.d.: 25.53%
 Number of outlier measurements: 4

